



# Designing and Installing On-Site Wastewater Management Systems

**A WaterNSW  
Current Recommended Practice**

January 2026

## Acknowledgements

'Designing and Installing On-site Wastewater Management Systems' (the Manual) was developed by WaterNSW with contributions by Joe Whitehead of Whitehead & Associates Environmental Consultants Pty Ltd and Kerry Flanagan of Kerry Flanagan Wastewater.

## Disclaimer

This document includes information about undertaking or assessing a development in the Sydney drinking water catchment. The information contained in this document is based on WaterNSW knowledge and understanding at the time of writing and should not be considered as error free or to include all relevant information.

WaterNSW tries to ensure that the information contained in this document is accurate, adequate and complete. WaterNSW does not make or give any representation or warrant its accuracy, adequacy or completeness, and recommends that users exercise their own skill and care with respect to its use. To the extent permitted by law, WaterNSW excludes any liability, including any liability for any negligence, breach of contract or statutory duty or any failure or the consequences of that failure in relation to the use of the information disclosed in this document.

## Copyright

Copyright in this document is owned by WaterNSW. WaterNSW owns all the present and future intellectual property in all the materials authored by it.

Subjected to the above, you may photocopy, distribute and otherwise freely deal with this publication for any purpose, provided that you attribute the information to WaterNSW, and you do not alter it in any way.

## WaterNSW

WaterNSW is the State-owned corporation responsible for managing bulk water supply. WaterNSW also acts to protect Greater Sydney's drinking water catchment through protecting the quality of the water supply.

More information about WaterNSW is at [www.watarnsw.com.au](http://www.watarnsw.com.au)

## Document Control

Version	Date	Document Administrator
Peer Review Draft	June 2010	Planning and Assessments, SCA
Industry Review Draft	May 2011	Planning and Assessments, SCA
Publication v.1	May 2012	Planning and Assessments, SCA
Publication v.1.1 (Peer reviewed)	November 2019	Catchment Protection, WaterNSW
Publication v.2	February 2023	Catchment Protection, WaterNSW
Publication v.3	January 2026	Catchment Protection, WaterNSW

# Table of Contents

<b>1</b>	<b>INTRODUCTION TO THE DESIGNING AND INSTALLING ON-SITE WASTEWATER MANAGEMENT SYSTEMS MANUAL</b> .....	<b>1</b>
1.1	THIS MANUAL .....	3
1.2	USING THIS MANUAL WITH OTHER GUIDELINES, STANDARDS AND TOOLS .....	4
1.3	TECHNICAL ISSUES AND PROBLEMS WITH EFFLUENT MANAGEMENT .....	4
1.4	DESIGNER AND INSTALLER – IMPROVING PRACTICE AND COMMUNICATION .....	4
1.5	HOW TO USE THIS MANUAL .....	7
<b>2</b>	<b>SITE SUITABILITY ASSESSMENT AND SYSTEM SELECTION</b> .....	<b>9</b>
2.1	ASSESSING THE WASTEWATER MANAGEMENT SITE .....	9
2.1.1	<i>Site constraints map</i> .....	9
2.1.2	<i>Soil information</i> .....	10
2.1.3	<i>Climate information</i> .....	11
2.2	WASTEWATER STANDARDS AND WATERNSW REQUIREMENTS .....	11
2.2.1	<i>Nutrient and hydraulic balances</i> .....	11
2.2.2	<i>Sizing the effluent management area (EMA)</i> .....	15
2.2.3	<i>Wastewater design loading</i> .....	15
2.3	SELECTING A SYSTEM .....	19
2.4	SYSTEM LOCATION .....	22
2.5	CASE STUDY .....	27
<b>3</b>	<b>SEPTIC TANKS</b> .....	<b>28</b>
3.1	DESIGN .....	29
3.2	INSTALLATION .....	30
3.3	TESTING .....	38
3.4	INSPECTION .....	38
3.5	OPERATION .....	38
3.6	COMMON TECHNICAL ISSUES .....	42
3.7	CASE STUDY .....	43
<b>4</b>	<b>AERATED WASTEWATER TREATMENT SYSTEMS</b> .....	<b>44</b>
4.1	INSTALLATION .....	48
4.2	TESTING .....	55
4.3	INSPECTION .....	55
4.4	OPERATION .....	55
4.5	COMMON TECHNICAL ISSUES .....	57
4.6	CASE STUDY .....	62
<b>5</b>	<b>BIOLOGICAL FILTER SYSTEM</b> .....	<b>63</b>
5.1	DESIGN .....	64
5.2	INSTALLATION .....	64
5.3	INSPECTION .....	72
5.4	OPERATION .....	72
5.5	COMMON TECHNICAL ISSUES .....	73
5.6	CASE STUDY .....	76
<b>6</b>	<b>COMPOSTING TOILETS</b> .....	<b>78</b>
6.1	DESIGN .....	78
6.2	INSTALLATION .....	80
6.3	INSPECTION .....	83
6.4	OPERATION .....	83
6.5	COMMON TECHNICAL ISSUES .....	83

6.6	CASE STUDY .....	85
<b>7</b>	<b>GREYWATER TREATMENT SYSTEMS .....</b>	<b>86</b>
7.1	DESIGN .....	87
7.2	INSTALLATION .....	87
7.3	TESTING .....	89
7.4	OPERATION AND MAINTENANCE .....	89
7.5	COMMON TECHNICAL ISSUES .....	89
7.6	CASE STUDY .....	93
<b>8</b>	<b>AMENDED SOIL MOUNDS .....</b>	<b>94</b>
8.1	DESIGN .....	94
8.2	INSTALLATION .....	95
8.3	INSPECTION.....	98
8.4	OPERATION .....	98
8.5	COMMON TECHNICAL ISSUES .....	102
8.6	CASE STUDY .....	102
<b>9</b>	<b>SAND MOUNDS .....</b>	<b>104</b>
9.1	DESIGN .....	104
9.2	INSTALLATION .....	105
9.3	INSPECTION.....	110
9.4	OPERATION .....	110
9.5	COMMON TECHNICAL ISSUES .....	114
9.6	CASE STUDY .....	115
<b>10</b>	<b>ABSORPTION TRENCHES AND BEDS .....</b>	<b>116</b>
10.1	DESIGN .....	116
10.2	INSTALLATION .....	119
10.3	TESTING .....	122
10.4	OPERATION .....	122
10.5	INSPECTION.....	129
10.6	COMMON TECHNICAL ISSUES .....	129
10.7	CASE STUDY .....	131
10.8	THE 'WICK' TRENCH AND BED SYSTEM .....	132
10.8.1	<i>Wick' trench and bed system design .....</i>	<i>133</i>
10.8.2	<i>Wick' trench and bed system Installation.....</i>	<i>135</i>
10.8.3	<i>Maintenance.....</i>	<i>137</i>
<b>11</b>	<b>EVAPOTRANSPIRATION ABSORPTION BEDS.....</b>	<b>138</b>
11.1	DESIGN .....	139
11.2	INSTALLATION .....	139
11.3	TESTING .....	145
11.4	OPERATION .....	145
11.5	INSPECTION.....	145
11.6	COMMON TECHNICAL ISSUES .....	146
11.7	CASE STUDY .....	148
<b>12</b>	<b>SURFACE IRRIGATION .....</b>	<b>149</b>
12.1	DESIGN .....	150
12.2	INSTALLATION .....	152
12.3	TESTING .....	155
12.4	INSPECTION.....	155
12.5	OPERATION .....	160
12.6	COMMON TECHNICAL ISSUES .....	160

12.7	CASE STUDY .....	161
<b>13</b>	<b>SUBSURFACE AND SUBSOIL IRRIGATION .....</b>	<b>163</b>
13.1	DESIGN .....	165
13.2	WICK SYSTEM.....	167
13.3	INSTALLATION .....	168
13.4	INSPECTION.....	175
13.5	OPERATION .....	175
13.6	COMMON TECHNICAL ISSUES .....	178
13.7	CASE STUDY .....	178
<b>14</b>	<b>SUPPLEMENTARY TECHNOLOGY .....</b>	<b>182</b>
14.1	TREATMENT WETLANDS.....	182
14.2	MEMBRANE SYSTEMS .....	182
14.3	TEXTILE FILTER SYSTEMS .....	182
14.4	SAND FILTERS .....	182
14.5	SUBSURFACE MEDIA TREATMENT SYSTEMS .....	183
14.6	BUFFERING / BALANCE TANKS .....	183
14.7	DOSING MECHANISMS .....	183
14.7.1	<i>Dosing siphon</i> .....	184
14.7.2	<i>"Flout®" Floating Outlet</i> .....	185
<b>15</b>	<b>ACRONYMS.....</b>	<b>188</b>
<b>16</b>	<b>GLOSSARY .....</b>	<b>189</b>
<b>17</b>	<b>REFERENCES AND FURTHER READING .....</b>	<b>193</b>
	<b>APPENDIX 1 – SYSTEM DESIGN STATEMENT .....</b>	<b>196</b>
	<b>APPENDIX 2 – DESIGN PRODUCER STATEMENT .....</b>	<b>201</b>
	<b>APPENDIX 3 – INSTALLATION CERTIFICATE .....</b>	<b>204</b>
	<b>APPENDIX 4 – STANDARD DRAWING 1 – UPSLOPE DIVERSION DRAIN .....</b>	<b>206</b>

# 1 INTRODUCTION TO THE DESIGNING AND INSTALLING ON-SITE WASTEWATER MANAGEMENT SYSTEMS MANUAL

Many on-site wastewater management systems installed in the Sydney drinking water catchment have failed from the day they began operating. WaterNSW recognises the common failure of systems in the Sydney drinking water catchment is partly due to the lack of readily available technical information about installations.

This Manual provides technical installation details not included in other guidelines or documents on on-site wastewater management. It brings together detailed design aspects of a variety of common effluent management systems and emerging technology. It provides checklists and standard drawings for approving authorities, system installers and owners. All information in the Manual relates to the Sydney drinking water catchment but may have a wider benefit elsewhere in NSW.

The Sydney drinking water catchment covers approximately 16,000 square kilometres and supplies drinking water to over 7 million people in Sydney, the Blue Mountains, the Illawarra and the Southern Highlands (Figure 1.1).

There are more than 11,000 on-site wastewater management systems in the Sydney drinking water catchment across 15 local government areas. A range of common technical and design faults encountered when installing on-site wastewater management systems can lead to health and water quality risks.

Development in the Sydney drinking water catchment is regulated by chapter 6 of State Environmental Planning Policy (Biodiversity and Conservation) 2021 (the B&C SEPP; formerly State Environmental Planning Policy (Sydney Drinking Water Catchment) 2011). Under chapter 6, Part 6.5 of the B&C SEPP, any development in the catchment that requires consent from council, including any on-site wastewater management system<sup>1</sup>, must have a neutral or beneficial effect on water quality (NorBE). This Manual will help meet the requirements of the B&C SEPP as they apply to on-site wastewater management systems.

On-site wastewater management systems are designed according to ['AS/NZS 1547:2012 On-site domestic wastewater management'](#) and the Office of Local Government (April 2025) 'Onsite Wastewater Management Guidelines' (which replaced the 1998 Environment & Health Protection Guidelines: On-site Sewage Management for Single Households' (the 'Silver Book')). However, it is recognised that these publications may not provide detailed and complete advice about properly installing on-site wastewater management systems. As a result, designs are often inadequate, and/or their objectives fail due to poor installation. When these systems fail, they present a risk to water quality and human health.

---

<sup>1</sup> Note: Notwithstanding that modifications to existing or installation of a new on-site wastewater management system under section 68 of the *Local Government Act 1993* not requiring consent are not required to have a neutral or beneficial effect on water quality. Councils and consultants should ensure that all modifications and installations are consistent with the intent of the B&C SEPP and this Manual.



## 1.1 This Manual

This Manual will help system installers, design consultants, property owners, council officers, WaterNSW officers, plumbers and contractors to ensure best practice methods are used to design and install on-site wastewater systems in the Sydney drinking water catchment. It is a technical Manual for design and construction that brings together and builds on existing documents about on-site wastewater management and plumbing.

The Manual gives practical and appropriate solutions for specific site constraints for the more common types of systems found in the catchment, and some supplementary technologies. Illustrated case studies and examples demonstrate common issues and suggest mitigation measures to minimise the risk of failure. There are annotated standard drawings, numerous tables, and checklists to assist with design, installation, construction and assessment of various on-site wastewater management systems, emphasising sound hydraulic design.

The Manual does not extensively cover choosing the size or type of system. This choice must be made according to '[AS/NZS 1547:2012 On-site domestic wastewater management](#)' and the 'Onsite Wastewater Management Guidelines' (Office of Local Government [OLG], 2025). Section 2 of the Manual describes how to interpret these documents together with WaterNSW's requirements.

This Manual provides recommendations to design, install, test, operate and inspect the following on-site wastewater treatment and effluent management systems:

- septic tanks
- aerated wastewater treatment systems
- biological filter systems
- composting toilets
- amended soil mounds
- Wisconsin sand mounds
- greywater treatment systems
- absorption trenches and beds
- evapotranspiration absorption beds
- surface irrigation systems
- subsurface irrigation systems.

The Manual identifies and describes practical approaches and solutions to key issues. Detailed, annotated standard drawings are provided to help the design, installation and inspection of various on-site wastewater treatment systems and land application (effluent management) options. Checklists are also provided to help designers, installers and regulators check that necessary information is collated and key tasks are completed at different stages. The checklists are extensive and may include items not relevant to a particular installation. They can be modified to suit individual needs.

## 1.2 Using this Manual with other guidelines, standards and tools

Under the B&C SEPP (chapter 6), new developments must be consistent with the NorBE Guideline (WaterNSW, 2025a). The NorBE Guideline requires that new developments or activities incorporate current recommended practices (CRPs) and standards endorsed by WaterNSW, or that alternative approaches be adopted that achieve the same or better water quality outcomes as outlined in CRPs. CRPs and standards provide best practice methods to manage the water quality impacts of a range of land uses, developments and activities including urban and rural subdivisions, agriculture, industrial developments, waste and recycling, stormwater and wastewater management, service stations and preparing environmental management plans.

This Manual is a CRP and supplements other existing guidelines and standards ([AS/NZS 1547:2012](#)) and the 'Onsite Wastewater Management Guidelines' (OLG 2025) for on-site wastewater management.

The document 'Developments in the Sydney Drinking Water Catchment – Water Quality Information Requirements' (WaterNSW, 2025b; available at [www.waternsw.com.au](http://www.waternsw.com.au)) is a performance standard developed by WaterNSW. This Manual should be read together with AS/NZS 1547:2012, the 'Onsite Wastewater Management Guidelines' (OLG 2025), and the water quality information requirements document.

The wastewater effluent model (WEM) is a GIS-based, effluent plume generation modelling tool used to evaluate on-site wastewater management systems designed using the above documents. The WEM is used to help decide whether NorBE on water quality is satisfied for developments where on-site wastewater management is required. It allows a visual interpretation and assessment of the potential impact of an on-site wastewater management system on water quality.

The WEM considers site and soil characteristics such as soil depth, permeability, phosphorus sorption capacity, slope and the proposed effluent management area. If the WEM shows the effluent plume reaches a watercourse, waterbody or drainage depression or leaving the boundaries of the site, then NorBE on water quality is not satisfied for the proposal. Wastewater management must be revised, including possibly relocating the effluent management area. If no alternative wastewater management solution is possible on the site, then consent must be refused.

Using this Manual should help ensure that an on-site wastewater management system that has been designed to achieve NorBE on water quality is installed correctly and maintained to continue to achieve NorBE on water quality throughout the system's life.

## 1.3 Technical issues and problems with effluent management

A wide range of technical issues and problems have been identified for on-site effluent management. They range from simple installation mistakes, such as not securing a tank into the ground, to larger design issues, such as having insufficient pump head capacity to adequately irrigate a large effluent application area. These issues are identified in the section for each system, however, some are common to a range of systems.

All on-site wastewater management systems should be installed according to NSW Workplace Safety requirements and [AS/NZS 3500 Set \(Parts 0-4\):2021 Plumbing and drainage](#).

## 1.4 Designer and installer – improving practice and communication

Currently most wastewater reports are high-level design documents that specify the nature, location and size of wastewater and effluent management systems. These reports invariably do not provide practical details of effluent management system design that accommodate site specific hydraulic requirements. The details of site-specific design are usually left to the installer and sometimes ignored altogether.

This Manual requires system designers to accept more accountability for the design, and improved communication between the designer and installer.

Better communication between the designer and installer is achieved by the designer preparing a 'System Design' that communicates critical details of the proposed system to the installer. It describes and quantifies the design and illustrates the appropriate layout and configuration of the system with appropriate plans and sketches, as well as a hydraulic design. For example, it should include a construction drawing to specify the location(s) of the effluent management field(s). Appendix 1 includes an example of a System Design Statement.

More accountability for the design is achieved through a 'Design Producer Statement', in which the designer warrants the design. Appendix 2 includes an example of a Design Producer Statement.

Finally, the installer must provide an 'Installation Certificate' that certifies that the system was installed according to the System Design, and the relevant sections of the of the Design Producer Statement. Appendix 3 includes an example of an Installation Certificate. A copy of the Installation Certificate(s) must be provided to council and the system designer. The council certifier will make a final inspection before the system is approved for use.

## NOTES

- The wastewater treatment system and effluent management system **must** be installed by a contractor(s) licensed by NSW Fair Trading. That could be a licensed plumber or a licensed irrigation contractor (or both), each with at least three years' experience in wastewater treatment and/or effluent management systems.
- The designer **must** have appropriate professional indemnity insurance for the system design.
- These templates have been developed in consultation with industry representatives.

Figure 1.2 shows the design and communication process. These documents clearly allocate the responsibility for the design and installation to the designer and licensed contractor(s) respectively. They provide a higher level of confidence for homeowners and regulators that the standards of design and installation are appropriately high.

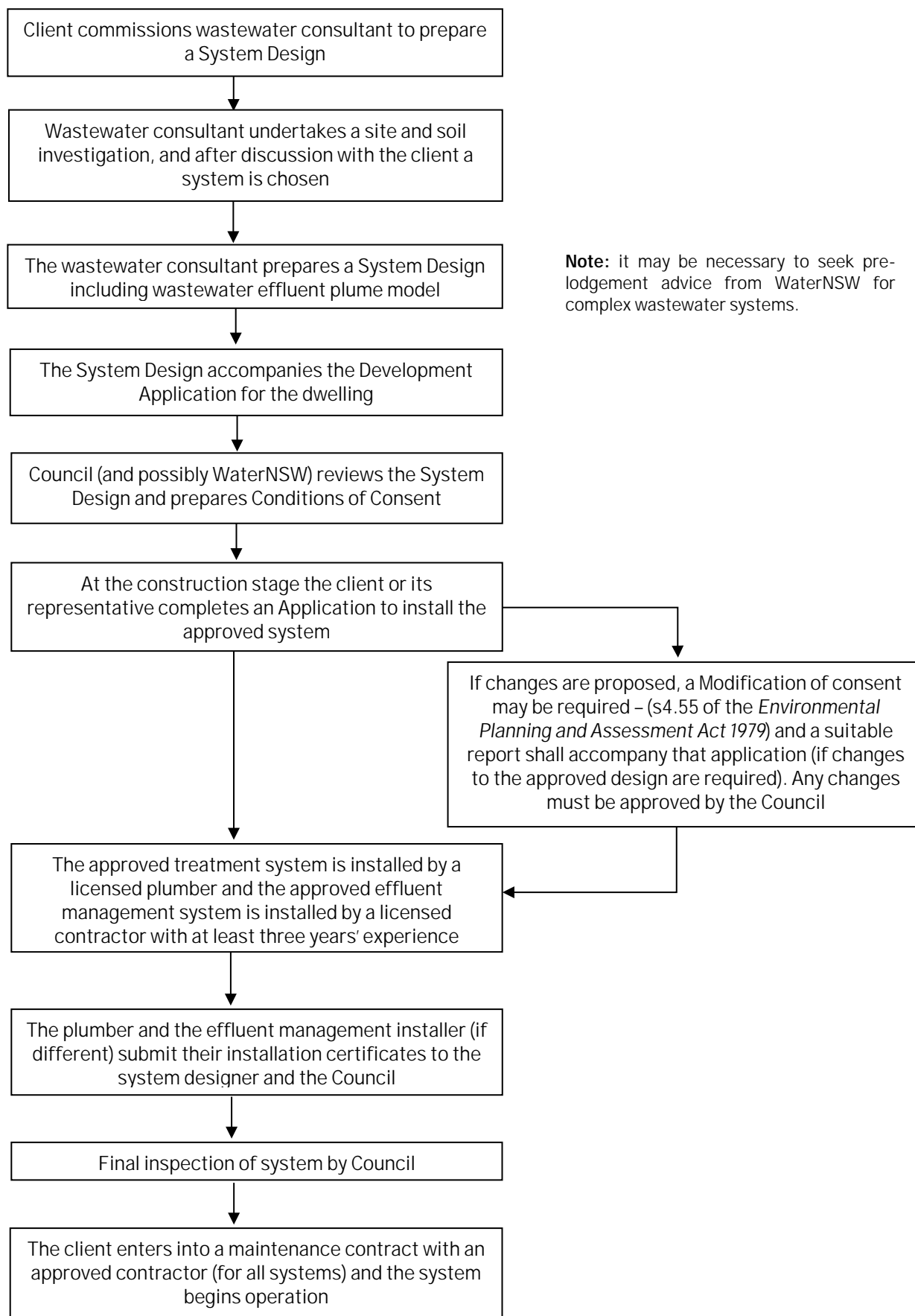

Figure 1.2 Flowchart to design and install an on-site wastewater system

## 1.5 How to use this Manual

For all systems, designers, installers and regulators should first consider the information in **Section 2** of this Manual that outlines the land capability assessment that must be completed for each site.

When the assessment is finished and a suitable system is chosen, Sections 3 to 7 and Section 14 are used to produce the treatment system design. Each system has various design elements to consider for installation, commissioning and operation. Each system type also has a number of suitable effluent management methods that can be selected. Sections 8 to 13 describe these different methods.

Each section includes information on:

- system design
- constructing and installing wastewater treatment and effluent management systems
- case studies
- common technical issues, and
- checklists for installers and regulators.

Table 1.1 lists each treatment system and effluent management option in this Manual. Users can select these from the Table and then refer to the appropriate colour-coded pages for detailed guidance on installing, testing, operating and inspecting the system.

Standard drawings are included throughout the document for reference and application in system designs. Standard Drawing 1 is referred to most frequently and is located at Appendix 4, whereas the others are included in each applicable section, for easy reference. Standard drawings included are:

- Standard Drawing 1 – Upslope Diversion Drain (Appendix 4)
- Standard Drawing 9A – Wisconsin Sand Mound
- Standard Drawing 10A – Absorption Trench / Bed
- Standard Drawing 10B – Pressure-dosed Bed / Trench
- Standard Drawing 10C – Raised Pressure Dosed Absorption Bed Construction
- Standard Drawing 11A – Evapotranspiration Absorption Bed
- Standard Drawing 12A – Demand Dose Pump well
- Standard Drawing 12B – Surface Irrigation of Effluent
- Standard Drawing 13A – Subsurface Effluent Irrigation
- Standard Drawing 13B – Raised Subsurface Irrigation Bed

**Table 1.1 Quick reference table based on treatment system and effluent management system type**

Select Treatment System Type	System Checklist Nos	Select Effluent Management Method	Checklist No's	Refer to Standard Drawing No's
<b>Section 3</b> Septic Tanks (including pump wells)	3.1	<b>Section 8</b> Amended Soil Mounds	8.1, 8.2	1 – Appendix 4
		<b>Section 9</b> Sand Mounds	9.1, 9.2	1 – Appendix 4, 9A
	3.2	<b>Section 10</b> Absorption Trenches and Beds (gravity and pressure dosed)	10.1, 10.2	1 – Appendix 4, 10A, 10B, 10C
		<b>Section 11</b> Evapotranspiration Absorption Beds	11.1, 11.2	1 – Appendix 4, 11A
<b>Section 4</b> Aerated Wastewater Treatment Systems (AWTS)	4.1	<b>Section 8</b> Amended Soil Mounds	8.1, 8.2	1 – Appendix 4
		<b>Section 9</b> Sand Mounds	9.1, 9.2	1 – Appendix 4, 9A
	4.2	<b>Section 10</b> Absorption Trenches and Beds (gravity and pressure dosed)	10.1, 10.2	1 – Appendix 4, 10A, 10B, 10C
		<b>Section 11</b> Evapotranspiration Absorption Beds	11.1, 11.2	1 – Appendix 4, 11A
		<b>Section 12</b> Surface Irrigation	12.1, 12.2	1 – Appendix 4, 12A, 12B
		<b>Section 13</b> Subsurface and Subsoil Irrigation	13.1, 13.2	1 – Appendix 4, 13A, 13B
<b>Section 5</b> Biological Filter Systems (including wet composting systems)	5.1	<b>Section 8</b> Amended Soil Mounds	8.1, 8.2	1 – Appendix 4
		<b>Section 9</b> Sand Mounds	9.1, 9.2	1 – Appendix 4, 9A
	5.2	<b>Section 10</b> Absorption Trenches and Beds (gravity and pressure dosed)	10.1, 10.2	1 – Appendix 4, 10A, 10B, 10C
		<b>Section 11</b> Evapotranspiration Absorption Beds	11.1, 11.2	1 – Appendix 4, 11A
		<b>Section 13</b> Subsoil Irrigation	13.1, 13.2	1 – Appendix 4, 13A, 13B
<b>Section 6</b> Dry Composting Systems / Toilets	6.1	<b>Section 10</b> Absorption Trenches and Beds (gravity and pressure dosed)	10.1, 10.2	1 – Appendix 4, 10A, 10B, 10C
	6.2	<b>Section 11</b> Evapotranspiration Absorption Beds	11.1, 11.2	1 – Appendix 4, 11A
<b>Section 7</b> Greywater Treatment Systems	7.1	<b>Section 10</b> Absorption Trenches and Beds (gravity and pressure dosed)	10.1, 10.2	1 – Appendix 4, 10A, 10B, 10C
		<b>Section 11</b> Evapotranspiration Absorption Beds	11.1, 11.2	1 – Appendix 4, 11A
	7.2	<b>Section 13</b> Subsoil Irrigation	13.1, 13.2	1 – Appendix 4, 13A, 13B
<b>Section 14</b> Supplementary Technologies	-	Various technologies to assist in effluent management	-	-

## 2 Site Suitability Assessment and System Selection

### 2.1 Assessing the wastewater management site

An experienced and appropriately qualified consultant must complete a site assessment for wastewater management describing the results of a site and soil assessment. WaterNSW's document *'Using a Consultant to Prepare Your Water Cycle Management Study'* (WaterNSW, 2025c), contains information about choosing and using a consultant to help prepare a water cycle management study or equivalent, which includes a wastewater report. The wastewater report will identify the capability of the site to sustainably manage treated wastewater or effluent. After discussion with the property owner the assessment must recommend a particular combination of a treatment system and effluent management method. This information must be provided in an on-site wastewater or wastewater report and submitted as part of the development application.

The wastewater report must include:

- specific details of the proposed wastewater treatment and effluent management method applied for, including the proposed site of the effluent management area (EMA). Note, the wastewater report must recommend a specific system and EMA, not a range of options
- a description of how appropriate the proposed system is for the frequency of use, available power, slope, soils, wastewater load and other site constraints as specified below
- a site map showing site constraints and the location of the proposed wastewater treatment system and effluent management area relative to key constraints and buffers
- for solar powered sites proposing a wastewater treatment system that requires continuous power for normal operation (such as aerated wastewater treatment systems), a detailed analysis is required outlining the power consumption of the system's normal operation (including power consumption of the pumps etc) in relation to the proposed power source and power storage capacity. The aerated wastewater treatment system must have a constant, and preferably, dedicated power source
- consideration of the physical practicality of a proposed gravity-fed system given the site slope and grade and whether a pump well is needed.

Appendix 1 of the 'Onsite Wastewater Management Guidelines' (OLG 2025), provides an appropriate template for wastewater reports. The report should refer to current references and standards e.g. 'AS/NZS 1547:2012 On-site Domestic Wastewater Management' and WaterNSW's *'Developments in the Sydney Drinking Water Catchment – Water Quality Information Requirements'* (WaterNSW, 2025b).

In most cases this Manual provides the standard for design and installation of on-site wastewater and effluent management systems. WaterNSW's *'Developments in the Sydney Drinking Water Catchment – Water Quality Information Requirements'* document indicates which other current recommended practice or performance standard to use where appropriate.

#### 2.1.1 Site constraints map

The wastewater report must include a site map identifying all surface constraints, including:

- the drainage network - inclusive of watercourses, drainage depressions and dams, roadside and other open drains (that are treated the same as drainage depressions). In unsewered village areas that are highly constrained, this may need to be discussed with WaterNSW.
- vegetation and shading/exposure

- orientation
- any poor drainage/wet seepage areas and springs
- river flats/ floodplains or flood planning level - If required, the application must accord with the 'flood planning' clause of the standard instrument, any applicable Floodplain Development Manual and the NSW Government 'Considering flooding in land use planning – Guideline' (DPIE, 2021).
- any existing or proposed groundwater bores located within 100 metres of the effluent management area (EMA) and their licenced use
- existing wastewater management structures and EMAs and whether they are to be retained or decommissioned
- slope (percentage or degrees)
- general landform
- areas of run-on
- rock outcrop and geology
- stormwater quality improvement devices
- all existing and proposed structures including buildings, access ways or roads, livestock yards
- buffer distances (see Table 2.6)
- exposed soil/ erosion potential/ fill etc.

### 2.1.2 Soil information

The wastewater report must include soil profiles of up to at least one metre or 600 millimetres below the base of the proposed effluent management system (whichever is deeper), taken at the specific locations of the proposed EMA, consistent with [AS/NZS 1547:2012](#). Photos of any soil core profiles and the proposed EMA must also be included.

The report must describe:

- soil texture and structure with depth using standard soil descriptions as per [AS/NZS 1547:2012](#) - weathered and decomposing rock of the C Horizon is not considered part of the soil profile when considering effluent management
- dispersibility (soil with an Emerson aggregate test class 1 are not generally suitable for effluent management (van de Graaff and Patterson, 2001))
- other relevant chemical or physical characteristics that could impact on sustainable effluent management – e.g. impeded drainage, as identified in the 'Onsite Wastewater Management Guidelines' (OLG, 2025) or [AS/NZS 1547:2012](#).

The report should also include the following where they are relevant to the site:

- electrical conductivity/salinity (soil with more than 8dS/m are not suitable for effluent management unless the soil is treated)
- sodicity (soils with more than 10% exchangeable sodium percentage are not suitable for effluent management unless the soil is treated)
- for permeable sandy or granitic soils, weighted phosphorus sorption values for the soil profile but only where effluent irrigation or an amended soil mound is proposed
- monthly rainfall and evaporation data.

Published soil data is broad scale and must be confirmed with site specific soil testing, as appropriate.

### 2.1.3 Climate information

Rainfall and evaporation data for the site and its implications for the nature and size of the EMA must be considered. This information is available in Figure 2.1 and Tables 2.1 and 2.2 of this Manual.

Where relevant, the impact of severe and prolonged frost should also be considered when choosing an effluent management system e.g. surface irrigation may not be suitable during winter.

## 2.2 Wastewater standards and WaterNSW requirements

On-site wastewater management systems must be designed in accordance with [AS/NZS 1547:2012](#) and the 'Onsite Wastewater Management Guidelines' (OLG, 2025). These documents include specifications to design and management of on-site wastewater management systems. However, they must be applied together with WaterNSW's requirements for nutrient and water balances, wastewater design loading rates and buffer distances.

### 2.2.1 Nutrient and hydraulic balances

Nutrient and hydraulic balances must be used for EMA sizing and wet weather storage to ensure a sound design for on-site effluent management. Rainfall and evaporation rates vary widely in the Sydney drinking water catchment. An important part of system design is ensuring that rainfall and effluent loads do not exceed the evapotranspiration rate and absorption capacity of the soil and ensuring that the vegetation and soil can readily assimilate the nutrients in the treated wastewater.

Hydraulic balances for effluent management should be calculated as per Appendix 6 of the 'Onsite Wastewater Management Guidelines' (OLG, 2025), using design irrigation rate data for the soil from Table M1 of [AS/NZS 1547:2012](#). Evaporation and rainfall data for various geographic zones (Figure 2.1) is provided in tables 2.1 and 2.2 to help calculate the hydraulic balance.

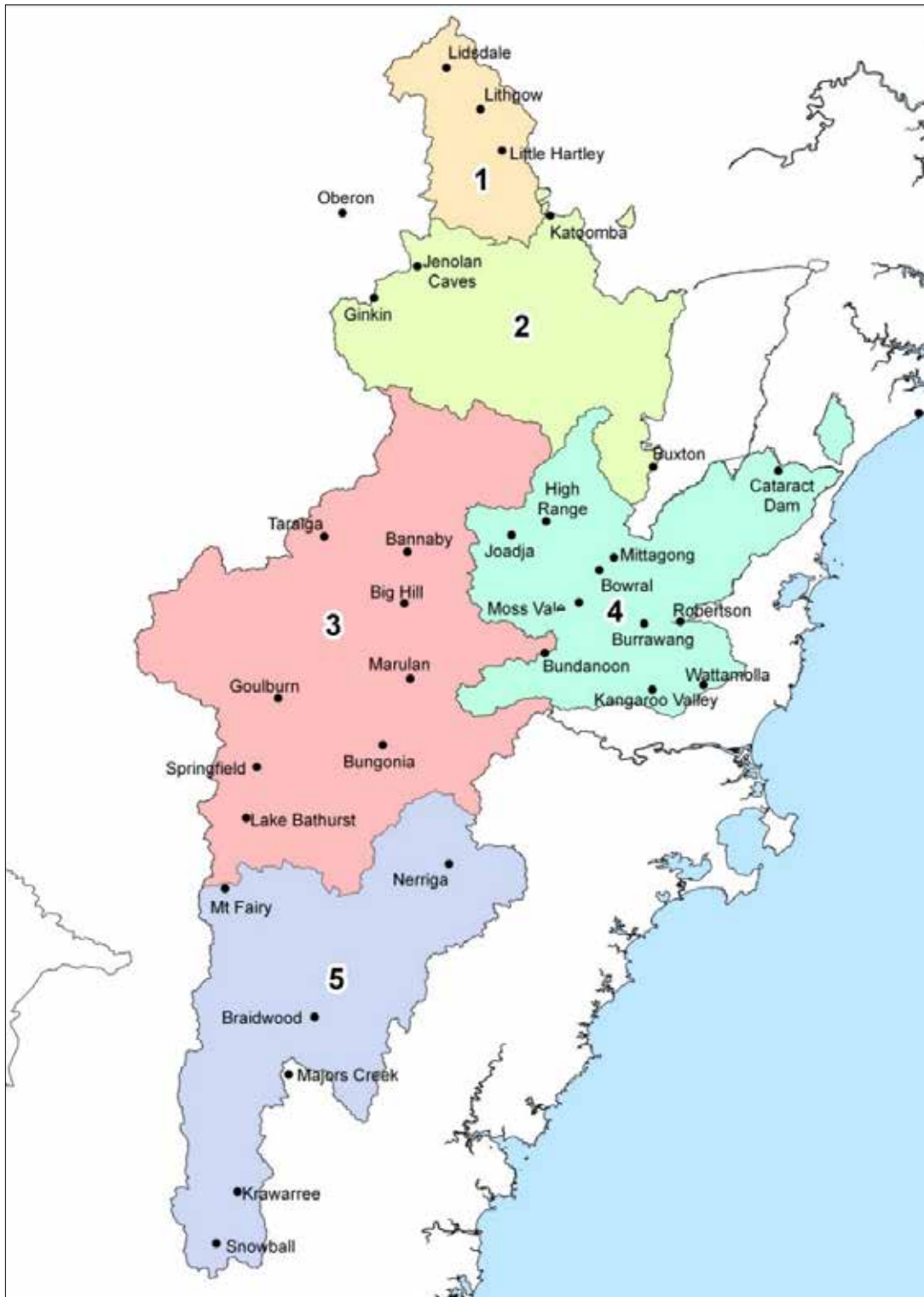

Figure 2.1 Map of catchment evaporation zones and rainfall stations

**Table 2.1 Catchment evaporation zone data (Source: SILO)**

Zone	Evaporation (mm/month)												
	Jan	Feb	Mar	Apr	May	Jun	Jul	Aug	Sep	Oct	Nov	Dec	Total
1	176	136	117	74	45	29	34	55	83	119	139	174	1180
2	200	158	139	97	66	49	56	81	110	146	166	203	1469
3	187	145	124	79	51	34	39	61	88	123	146	185	1261
4	171	134	116	78	53	38	44	68	94	125	141	173	1234
5	198	156	135	88	60	44	49	73	99	134	157	195	1388

**Table 2.2 Mean rainfall (Source: BOM)**

Station	Mean Rainfall (mm/month)												Annual Average
	Jan	Feb	Mar	Apr	May	Jun	Jul	Aug	Sep	Oct	Nov	Dec	
Lidsdale	108.5	85.2	71.2	59	66.2	74.3	52.2	65.8	59.4	84.4	74.1	74	873
Lithgow	94.3	83.8	83.9	62.7	63.0	67.6	67.6	63.4	58.9	67.7	70.0	76.1	861.8
Little Hartley	84.2	77.9	70.6	59.4	53.8	67.2	61.4	51.7	45.1	58.8	59.2	72.6	762
Katoomba	161.9	175	168.6	121.3	99	118.9	81.8	78.7	71.1	91.8	108.8	122.4	1401.9
Oberon (Jenolan Caves)	93.2	93.5	80	72	63.5	86.6	80.3	82.8	66.3	77.8	77	86.5	967.9
Ginkin	94.2	84.4	93.8	64.6	78.4	84.4	76.2	88.8	71.6	87.1	83.6	74.6	1007
Oakdale	102.2	126.6	111.2	75.7	48.6	84.2	32	44.1	43.6	74.8	96.7	77.1	890.7
Buxton	91	124.3	81.1	72.7	50.7	67	35.2	50.5	44.3	61.9	90.2	77.2	853.4
Taralga PO	72.7	69.8	67	58.6	58.8	76	66.3	67.4	61.4	69.4	67.7	66.7	804.7
Bannaby	85.1	88.6	73.7	59.5	53.6	61.3	45.2	49.9	48.3	69.9	73.4	68.7	791
Marulan	67.4	71.8	68.3	50.8	52.6	64.5	49.6	45.7	46.7	60.3	60.3	62.1	710.3
Goulburn TAFE	61.9	60.7	55.6	44	40.7	53.1	40.8	52.5	48	52.5	62.6	62.8	624.6
Springfield	64.1	62.1	57.6	47.6	46.5	54.1	46.3	50.7	49.2	63	62.7	60.1	667.3
Bungonia	66.2	64.1	64.8	51.6	48	60.7	42.1	45.1	45.9	54.8	57.9	60.2	660.1
Lake Bathurst	67.1	59.4	57.9	50.8	45.9	55.7	45	51.8	52.5	66.2	64.8	60	682.1
Cataract Dam	93.7	115.7	108.8	99.2	97.2	112.5	75.8	70.4	55.4	77.6	78.6	77.6	1065.3
High Range	83.3	92.4	81.1	69.1	62.6	68.4	48.1	48.7	47.1	64.9	73.5	74.4	816.8
Wingello	112.5	131.5	100.5	80.2	96.6	119.1	60.3	65.3	59.5	91	79.4	97.6	1092.5
Mittagong	86.1	91.5	94.3	74.7	73.2	89.8	66.1	56.8	52.2	64.2	70.6	75.7	910.9
Bowral	81.9	98.4	95.2	75.8	69.6	84	45.3	61.6	55.8	71.6	92.4	78.6	931.7
Moss Vale	88.3	96.3	92	80.5	82.1	101.4	74.1	65	59.1	73.5	73	77.2	961.2
Belanglo	71	86.2	81.6	59.7	52.5	67.2	43.3	55	50	57.2	70.2	62	779.4
Bundanoon	110.4	122.3	119.1	94.9	97.4	113.1	77.9	74.2	67.6	88.7	81.4	94.1	1155.6
Burrawang	112.8	121.9	125.5	132.7	128.4	164	133.9	97.3	82.3	88.1	83.2	101.7	1377.4
Robertson	149.2	166.4	193.5	152.2	138.6	187	123.6	110.8	92.2	117.6	110.3	120.8	1675.2
Wattamolla	131.3	184.6	182.4	136.3	115.9	163.7	81	105.2	86.5	104.1	122.6	96.8	1534.1
Kangaroo Valley	109.2	133.4	130.6	113.6	109.6	149.6	81.9	88.5	78.1	99.5	86.3	93.1	1288.2
Mt Fairy	64.8	59.7	62.4	51.7	54.2	63.5	54.1	50.7	55.4	62.4	65.2	60.7	718.1
Nerriga	67.7	65.5	73.6	55.9	59.5	72.1	60.6	55.4	52.9	62.3	64.5	64.9	769.1
Braidwood	69.7	67.1	69	54.6	55.6	66.3	45.4	48.3	50	61.8	63.4	65	719.2
Majors Creek	89.5	103.7	109.2	65.9	63.1	87.5	64.6	60	63	79.6	77.6	73.7	944.5
Krawarree	79.2	82.5	82	61.4	55.9	66.9	49.7	48.5	51.1	66.7	74.7	71.7	794
Snowball	92.5	81.9	89.4	67.4	50.9	78.8	69.8	62.1	65.8	69.9	82.1	92.2	916.3

It is more important to include wet weather storage in hydraulic balance designs in wet areas where the average annual rainfall is more than 1200 millimetres. Where a proposed effluent management area has separate locations and/or different elevations, the wastewater report must identify specific hydraulic design requirements to ensure the system will work effectively. All evapotranspiration absorption beds should be designed according to [AS/NZS 1547:2012](#), using a hydraulic balance, to ensure appropriate bed size.

Nutrient balances must be calculated for sizing effluent management areas. Inputs should include design hydraulic loading, soil depth, soil bulk density, effluent quality, vegetation uptake for an appropriate vegetation type and soil phosphorus sorption rates. Managed lawn and slashed paddocks have different vegetation uptake values and must be treated differently. Data provided by WaterNSW is useful for indicative phosphorus sorption values (Table 2.3) and nutrient uptake rates (Table 2.4); however site-specific information is required where an irrigation system is proposed.

**Table 2.3 Phosphorus Sorption Uptake Values**

Soil Category	Texture	Structure	Acceptable P <sub>sorp</sub> * (mg/kg)
1	Gravels and sands	Structureless	50
2a	Sandy loams	Weak	100
2b	Sandy loams	Massive	100
3a	Loams	High / moderate	200
3b	Loams	Weak / massive	200
4a	Clay loams	High / moderate	400
4b	Clay loams	Weak	400
4c	Clay loams	Massive	400
5a	Light clays	Strong	500
5b	Light clays	Moderate	500
5c	Light clays	Weak / massive	500
6a	Med-heavy clays	Strong	600
6b	Med-heavy clays	Moderate	600
6c	Med-heavy clays	Weak / massive	600

\* If soil parent material is basalt then increase P<sub>sorp</sub> by 100mg/kg

**Table 2.4 Nutrient Uptake Rates**

Vegetation Type	Total Nitrogen (kg/ha/year)	Total Phosphorus (kg/ha/year)
Good quality woodland	90	25
Poor quality woodland	65	20
Lawn - fully managed (clippings removed)	240	30
Lawn - unmanaged	120	12
Improved pasture	280	24
Perennial pasture	99	11
Shrubs and some trees - fully managed	150	16
Shrubs and some trees - unmanaged	75	8

For **bulk density (g/cm<sup>3</sup>)**, apply the following values:

Sandy soil – 1.8g/cm<sup>3</sup>

Intermediate – 1.5g/cm<sup>3</sup>

Clayey soil – 1.3g/cm<sup>3</sup>

## 2.2.2 Sizing the effluent management area (EMA)

The design area for surface and subsurface effluent irrigation (i.e. the area where the irrigation system is installed) can be based on hydraulic loading with a dedicated nutrient uptake area downslope or around the EMA for a flat site. The dedicated nutrient uptake area is the difference in area between the nutrient load area (the larger of the nitrogen or phosphorus balance) and hydraulic load area. The nitrogen and phosphorus nutrient loading areas should be sized as per the 'Onsite Wastewater Management Guidelines' (OLG, 2025) and/or the equation by Daniel Martens as specified in the '*Neutral or Beneficial Effect on Water Quality Assessment Tool: Consultant and Consultant Administrators User Guide*' (WaterNSW, 2025d).

Where a proposal involves wastewater loads greater than 10 Equivalent Persons (EP), advice should be sought from WaterNSW via [Environmental.Assessments@waterNSW.com.au](mailto:Environmental.Assessments@waterNSW.com.au).

### Considerations when sizing EMAs:

- The size of the absorption trenches and beds, and evapotranspiration absorption beds, **must** be based on the design wastewater load and site and soil characteristics as per [AS/NZS 1547:2012](#). For primary treated effluent, the conservative design loading rate must be used.
- The size of sand mounds should be based on Converse and Tyler's (2000) 'Wisconsin mound soil absorption system: Siting design and construction manual', and design loading rates in Table N1 of the [AS/NZS 1547:2012](#). Simply applying the design loading rates in Table 5.2 of the [AS/NZS 1547:2012](#) is not appropriate to size mounds.
- The irrigation area for surface and subsurface effluent irrigation should be based on the hydraulic balance for the design wastewater load and site soil characteristics, with a dedicated nutrient uptake area downslope and/or around the irrigation field, determined by the difference in area between the nutrient load (the larger of the nitrogen or phosphorus balance) and hydraulic load area - as per [AS/NZS 1547:2012](#) and the 'Onsite Wastewater Management Guidelines' (OLG, 2025).
- Phosphorus sorption values in the phosphorus loading example in the 'Silver Book' must not be used, as the phosphorus sorption value is not typical of most locations in the Sydney drinking water catchment. Site specific weighted phosphorus sorption values must be used to determine the size of the effluent irrigation area based on nutrient balances. The phosphorus sorption values in Table 2.3 are indicative only.
- Phosphorus sorption data in milligrams per kilogram (mg/kg) is converted to kilograms per hectare (kg/ha) using the following equation (see Table 2.3 for indicative bulk density values):
$$P_{sorp} \text{ (kg/ha)} = P_{sorp} \text{ (mg/kg)} \times \text{soil depth (m)} \times \text{bulk density (kg/m}^3\text{)} \times 0.01$$
- For amended soil mounds, determine the size using the design wastewater load and the design loading rate for the limiting layer within 600 millimetres of the point of application (i.e. the base of any underlying sand layer) at the upslope side of any bench on which the mound is constructed.

## 2.2.3 Wastewater design loading

When choosing a system, the capacity of the system to manage the daily wastewater load without overloading the system must be considered. For example, some aerated wastewater

treatment systems struggle to effectively accommodate variable loads from holiday homes where the system may not be used at all on weekdays, but a whole family or larger group may use it on weekends and holidays for successive days. Bacteria needed to treat the wastewater can die off when there is no or low inflow and take time to regenerate once higher flows restart. This can result in poor or ineffective treatment in the meantime.

For a proposed dwelling (including dual occupancies) the design wastewater loading must be determined using the 'NorBE Guideline' (WaterNSW, 2025a) based on:

- the number of potential bedrooms<sup>2</sup> (which can't change, unlike the number of occupants)
- the nature of the water supply i.e. whether the dwelling uses town or bore water, or tank water
- the wastewater loading per bedroom based on the nature of the water supply.

Table 2.5 should be used to calculate the daily wastewater load for a dwelling together with any specific requirements of the relevant local council. For other developments (non-dwelling) involving wastewater, refer to:

- [AS/NZS 1547:2012](#) On-site domestic wastewater management;
- Sewage Management Facility Vessel Accreditation Guideline (NSW Health, 2016);
- Secondary Treatment System Accreditation Guideline 2018 (NSW Health, 2018); and/or
- other reference source endorsed by WaterNSW.

**Table 2.5 Design wastewater loading calculations (for a dwelling)**

Design wastewater loading for each potential bedroom	Reticulated / bore water	Tank water
1-2 potential bedrooms	600L/d	400L/d
3 potential bedrooms	900L/d	600L/d
4 potential bedrooms	1,200L/d	800L/d
More than 4 potential bedrooms	1,200L/d plus 150L for each additional bedroom	800L/d plus 100L/d for each additional bedroom
<p><b>Source:</b> <i>NorBE Guideline (WaterNSW 2025a) &amp; Developments in the SDWC (WaterNSW, 2025b)</i>            Note: WaterNSW adopts a conservative approach for wastewater design calculations. Water saving fixtures should be standard in all new dwellings.</p>		

To determine the effluent design loading rates or design irrigation rates use the values for the identified soil description (texture and structure) in Tables L1, M1 and N1 of [AS/NZS 1547:2012](#). Use the conservative design loading rates for septic tanks, absorption trenches and beds.

Septic tanks for residential developments must be at least 3,000 litres. Larger tank capacities must be based on design wastewater loads detailed in Table J1 in [AS/NZS 1547:2012](#). If a spa bath is proposed as part of a development, the minimum septic tank size must be increased by 500 litres.

<sup>2</sup> As per the Onsite Wastewater Management Guidelines (Office of Local Government [OLG], 2025), bedrooms are defined as any room that possess the potential to be used as a bedroom in the future. Generally, any room that contains a door and window is considered a potential bedroom and includes rooms such as studies, games/media rooms, home gyms and studios. It is up to the discretion of the council to determine whether or not a room is considered a bedroom for design purposes.

For greywater-only systems, use a value of 65% of the design wastewater load calculated above. Otherwise greywater systems are treated exactly the same as other wastewater systems.

### **Linear loading rate for beds, trenches, sand and amended soil mounds**

The hydraulic linear loading rate is the amount of effluent that the soil around an effluent infiltration system can carry far enough away from the infiltration surface for it to no longer influence the infiltration of additional effluent (Tyler, 2001). It must be used in conjunction with the effluent design loading rates (DLR) from [AS/NZS 1547:2012](#). DLRs assume there is no hydraulically limiting layer beneath the base of the EMA; the linear loading rate is designed to ensure that the effluent cannot return to the surface as it travels downslope due to the presence of a hydraulically limiting layer.

So that soil absorption components deliver no more than the receiving soil can carry away from the site, maximum linear loading rates should be calculated based on the soil depth, soil morphology and the gradient of the slope. The linear loading rate is a critical design element for on-site wastewater management systems whenever the vertical movement of water in the soil is restricted.

Since the hydraulic linear loading rate does not depend on the quality of the effluent applied, the linear loading rate values are the same for all application infiltration rates. The linear loading rates are listed in Table 2.6 below.

### **Minimum separation requirements**

To ensure unsaturated flow conditions and to better filter effluent, the treatment system design must include **minimum** separation distances from the bottom of the beds, trench or mound to the limiting layer (e.g. bedrock or groundwater). This distance should be a minimum of 600 millimetres for all systems.

**Table 2.6 Linear loading rates**

(Based on 'Hydraulic Wastewater Loading Rates to Soil' Tyler EJ, 2001)

Soil characteristics			Linear loading rates (litres/metre/day)								
			Slope								
			<5%			5-10%			>10%		
Soil category	Soil texture	Structure	Depth of natural, unsaturated soil (cm)								
			20 - 30	31 - 60	>61	20-30	31-60	>61	20-30	31-60	>61
1	Gravels and medium-coarse sands	Structureless	50	62	75	62	75	87	75	87	99
	Fine sand and loamy sand	Structureless	43	56	68	50	62	75	62	75	87
2	Sandy loams	Weakly structured	43	56	68	50	62	75	62	75	87
		Massive	37	43	50	45	51	57	62	75	87
3	Loams	High/moderate structured	41	47	53	45	51	57	48	55	61
		Weakly structured or Massive	25	29	32	30	34	37	34	40	46
4	Clay loams	High/moderate structured	30	36	42	34	37	41	37	43	50
		Weakly structured	25	31	37	27	34	40	30	36	42
		Massive	N/A	N/A	N/A	N/A	N/A	N/A	N/A	N/A	N/A
5	Light clays	Strongly structured	25	31	37	27	34	40	30	36	42
		Moderately structured	25	31	37	27	34	40	30	36	42
		Weakly structured or Massive	N/A	N/A	N/A	N/A	N/A	N/A	N/A	N/A	N/A
6	Medium to heavy clays	Strongly structured	25	31	37	27	34	40	30	36	42
		Moderately structured	25	31	37	27	34	40	30	36	42
		Weakly structured or Massive	N/A	N/A	N/A	N/A	N/A	N/A	N/A	N/A	N/A

## 2.3 Selecting a system

After confirming that the site can accommodate an on-site wastewater management system, a specific system can be chosen. The chosen system should suit the range of site and soil constraints and the owner's needs. Consider the following items when choosing the system.

### Regulatory requirements

All domestic wastewater and greywater systems installed in NSW must be accredited by NSW Health. A regulatory authority cannot approve the installation of a non-accredited wastewater system, except where the system is specifically and individually designed for the site and adequate supporting information is provided with the design. Accredited systems are listed on the NSW Health website

<http://www.health.nsw.gov.au/environment/domesticwastewater>

### System location

The location of a system on a site can greatly affect its long-term performance. For drainage, using gravity instead of pressured delivery by pump or siphon or other dosing device can constrain the effluent management system performance. Wastewater must reach the tank or treatment system, and effluent must also be evenly distributed throughout the effluent management area.

### Owner requirements

Choosing a system that suits the owner's interests can help ensure that they properly manage and maintain it. If a property owner has a system that does not suit their needs or expectations, they are less likely to maintain it. In areas with water restrictions, property owners often want a system that can supply treated effluent for reuse. Where this type of system is suitable for the site, it would be best to install a system that meets the owner's expectations.

### Site and use considerations

#### Electricity

Many treatment systems that need pumps, timers, aerators, ultraviolet treatment or any other automated process are not suitable for sites with no mains power. A limited number of systems are suitable for these cases, including septic tanks, waterless composting toilets, and some worm farms that only need intermittent power.

Many aerated wastewater treatment systems (AWTS) need a continuous electricity supply to power the aerator and intermittent supply to power the pump.

WaterNSW accept solar power for systems where continuous power is needed for normal operation, such as an AWTS, only when a detailed analysis is provided as part of the application. The analysis must outline:

- the capacity of the solar power system (and back-up supply) to cater for the wastewater treatment system and the entire household power demand. This should indicate whether a separate converter or battery bank will be installed to supply the treatment system components alone. The AWTS (or other wastewater treatment system) must have a constant, and preferably, dedicated power source
- the capacity of the solar power system to sufficiently power all electrical components of the AWTS (or other treatment system) without the voltage supply dropping (including pump start-up surges) and shall include a stable 240 Volt AC inverter to operate each electrical component of the AWTS
- sufficient back-up battery/power supply (such as a generator) for the solar power supply system to be configured to automatically provide power where solar power is not available, and

- details of alert system (e.g. an alarm) to be installed and triggered when power to the AWTs is disconnected. Power shall be reconnected to the AWTs as soon as practical.

### Intermittent loads

Systems for sites that only receive intermittent loads, such as holiday houses, include septic tanks, some worm farms and waterless composting toilets. Some systems, including aerated wastewater treatment systems, struggle to effectively manage variable loads from holiday homes, where the system may not be used at all on weekdays, but large loads are contributed for several days on weekends and in holiday periods. The bacteria needed to treat the wastewater can die off when there is no or low inflow and can take time to regenerate once higher flows restart, resulting in poor or ineffective treatment in the meantime.

### Frosts

Where sites are subject to prolonged or severe frosts, surface irrigation is generally not acceptable, although a summer surface / winter subsurface hybrid system may be acceptable.

### **Approved effluent management methods**

Not all wastewater treatment system types are approved for the same effluent disposal or management methods. Generally, all aerated wastewater treatment systems with disinfection are approved by NSW Health for surface or subsurface irrigation. However, NSW Health would only approve a secondary treatment system without disinfection for subsoil management (more than 300 millimetres depth). These include worm farms. Although not commonly practised, applying secondary treated effluent from an aerated wastewater treatment system to an absorption trench or evapotranspiration bed on a constrained site is a viable alternative where there is not enough area for irrigation. It should be noted that applying secondary treated effluent to an absorption trench or evapotranspiration bed also decreases the chance of failure of the effluent management system.

The system designer must ensure the proposed effluent management method will meet regulatory requirements. Guidance on approved effluent management methods can be found in the NSW Health Advisory Note No 4 – January 2017 'Recommended Final Uses of Effluent based on the Type of Treatment'.

When considering installing surface irrigation for effluent management, the following factors must be considered on a case-by-case basis:

- whether the site experiences severe and prolonged frosts (a summer surface / winter-subsurface hybrid system may be acceptable)
- proximity of neighbours
- proximity of the proposed irrigation area to the dwelling
- annual average rainfall (should be less than 1,200 millimetres)
- slope of the effluent irrigation area (should be less than 10%)
- whether council requires subsurface irrigation.

If these factors are not addressed, WaterNSW will require subsurface irrigation using either a capillary system, wick-based system, or pressure compensating drip emitters with root barriers. Subsurface irrigation is acceptable on slopes up to 30%, but for slopes over 10% the Design Irrigation Rate should be reduced as indicated in Table M2 of AS/NSZ 1547:2012.

Where surface irrigation is proposed, WaterNSW does not allow the use of moveable hoses, including semi-fixed systems. Developments need fixed sprinkler points using pop-up sprinklers (except for lawns or gardens close to the dwelling), or quick coupling valves or similar. Sprinklers must be rotated throughout the effluent irrigation area or employ an auto-sequencing valve. Sprays must not generate aerosols and must have a suitable throw and plume height for the site.

This will vary depending on proximity to buildings, recreation areas and other sensitive environments. Ongoing maintenance and grass mowing must also be considered.

The sprinkler kits and hoses supplied by most aerated wastewater treatment system manufacturers are **not** suitable or acceptable, as the supplied hoses are generally soft and not suitable for burial, and the number of sprinklers generally supplied is insufficient for the required (fixed) coverage.

### Special considerations

WaterNSW will require all effluent management areas to be fenced off from livestock or vehicles. Where the effluent management area is on a house block that livestock cannot access, it must still be protected from vehicles but may not need to be fenced.

WaterNSW will not accept:

- absorption trenches where the soil is medium or heavy clay<sup>3</sup>
- absorption trenches where there is less than 0.75 metres of soil
- a trench system with a total length of more than 200 metres (lineal)
- trenches more than 20 metres long, except where they are made of two separate inline trenches with a central feeder, or where trenches are pressure dosed from a pump well (in these cases, the applicant should consider absorption beds instead)
- amended soil mounds on slopes of more than seven percent (four degrees) - WaterNSW may, in exceptional circumstances, consider amended soil mounds for slopes that are more than 7-10.5% (4-6 degrees) if the mound bench is built up with consolidated topsoil and is not cut into the slope
- reed bed systems to treat and dispose of effluent – WaterNSW may in exceptional circumstances accept reed bed systems. These systems are considerably influenced by climatic conditions, potentially leading to system failure or inability to meet operating requirements. For example, in the drier parts of the Sydney drinking water catchment complete vegetation cover is unlikely to be sustained; in the colder climates, nutrient uptake is much less and may not be enough to meet requirements, and for those sites located in high rainfall areas, system overflows can be a problem.
- pump-out systems for domestic situations, except where a location will probably be seweraged in the near future - Pump out systems are not sustainable and are often the worst performing on-site wastewater management systems due to misuse and poor practices. They may be considered in exceptional circumstances, on a case-by-case basis, where effluent management is on a heavily constrained site, such as a manned pumping station on the steep banks of a river. They may also be considered where council does not allow on-site effluent management below a certain lot size, or the area is not and will not be serviced by a reticulated sewerage system. Where pump-out systems are approved they must be:
  - large enough for the development (minimum septic tank size for domestic systems/residential purposes of 4,500 litres) – collection wells for an effluent pump-out system that relies on total water harvesting must be sized according to Table 2.7
  - appropriately designed and/or anchored e.g. tank and lid have an appropriate weight to ensure no tank buoyancy problems
  - equipped with an indicator for wastewater level and an alarm for excess wastewater levels
  - equipped with a readily accessible pump-out stand with a 'Kamlock' (or similar) cover

---

<sup>3</sup> Absorption trenches in medium to heavy clay may be considered in exceptional circumstances only and may require soil modification.

- equipped with a small spillage well with a valve for the pump-out pipe
- pumped out regularly by a pump-out contractor.

Applicants should also be aware of council requirements for wastewater management.

**Table 2.7 Collection well sizes (based on fortnightly pump-outs)**

Number of bedrooms	Collection well size (litres)
3	15,000
4	19,500
5	21,500
6	23,000

Existing wastewater treatment systems must be decommissioned according to the NSW Health Advisory Note No 3 for 'Destruction, Removal or Reuse of Septic Tanks, Collection Wells, Aerated Wastewater Treatment Systems (AWTS) and Other Sewage Management Facilities (SMF)' (2017).

## 2.4 System location

The location of a system on the site can greatly affect its long-term performance. The site plan in the wastewater report, submitted with the development application, must clearly show the location of the proposed effluent management areas (see Appendix A of Developments in the Sydney Drinking Water Catchment – Water Quality Information Requirements, WaterNSW, 2025b). It must show their position in relation to buffer distances to drainage features, any nearby groundwater bores on the site or nearby adjoining properties, and setback distance to property boundaries, buildings and other infrastructure (existing and proposed). The drainage features are not simply the blue lines shown on contour maps but should be mapped for the site and open roadside drains should be treated as drainage depressions. In unsewered village areas that are highly constrained this may need to be discussed with WaterNSW.

The site plan must also show the location of any existing wastewater system tanks, piping and effluent management areas that will be augmented or decommissioned, or where these systems are located close to a new on-site wastewater management system. The site plan must be clear enough for an assessor to accurately locate the proposed effluent management area.

### Buffer distances

The Office Local Government and WaterNSW both have buffer setbacks that apply to on-site wastewater management systems to protect public health and the environment. When treating and disposing of wastewater in the Sydney drinking water catchment, WaterNSW applies conservative buffer distances to protect water quality.

In the Sydney drinking water catchment, the location of a system must comply with the buffer setbacks outlined in Table 2.8.

**Table 2.8 Buffer distances**

Feature	Level of effluent treatment	Effluent application method	Buffer distance (minimum)	Achievable
Buildings (e.g. farm shed/ out building/ detached garage), retaining walls	Primary	Subsoil	2.0 m downslope and where flat, or 6.0 m upslope of the feature	<input type="checkbox"/> Yes <input type="checkbox"/> No <input type="checkbox"/> N/A
	Secondary (disinfected)	Subsurface and surface irrigation (including spray, drip or trickle)	2–6 m (<3m only for drip irrigation on low rate)	<input type="checkbox"/> Yes <input type="checkbox"/> No <input type="checkbox"/> N/A
Inhabited dwelling		Surface irrigation	15 m up- or downslope of the feature	<input type="checkbox"/> Yes <input type="checkbox"/> No <input type="checkbox"/> N/A
Property boundaries, driveways, paths and walkways, recreation areas	Primary	Subsoil	3.0 m downslope and where flat, or 6.0 m upslope of the feature; 15 m to recreation areas, if by LPED irrigation	<input type="checkbox"/> Yes <input type="checkbox"/> No <input type="checkbox"/> N/A
	Secondary (disinfected)	Subsurface irrigation	3.0 m downslope and where flat, or 4.0 m upslope of the feature	<input type="checkbox"/> Yes <input type="checkbox"/> No <input type="checkbox"/> N/A
		Surface irrigation	15 m up- or downslope of the feature	<input type="checkbox"/> Yes <input type="checkbox"/> No <input type="checkbox"/> N/A
In ground potable water tanks, in ground swimming pools	Primary	Subsoil	15 m and downslope from water tank or pool	<input type="checkbox"/> Yes <input type="checkbox"/> No <input type="checkbox"/> N/A
	Secondary (disinfected)	Subsurface and surface irrigation	4.0 m - should not be located upslope of feature	<input type="checkbox"/> Yes <input type="checkbox"/> No <input type="checkbox"/> N/A
Watercourses, lakes and the full supply level for all water supply reservoirs	Primary	Subsoil	100 m from the high water level	<input type="checkbox"/> Yes <input type="checkbox"/> No <input type="checkbox"/> N/A
	Secondary (disinfected)	Subsurface and surface irrigation	100 m from the high water level	<input type="checkbox"/> Yes <input type="checkbox"/> No <input type="checkbox"/> N/A
Bore or well licenced for domestic <sup>^</sup> consumption	Primary	Subsoil	100 m	<input type="checkbox"/> Yes <input type="checkbox"/> No <input type="checkbox"/> N/A
	Secondary (disinfected)	Subsurface and surface irrigation	100 m	<input type="checkbox"/> Yes <input type="checkbox"/> No <input type="checkbox"/> N/A
Drainage depressions, farm dams and roadside drainage and lot scale stormwater quality improvement devices-	Primary	Subsoil	40 m from the high water level	<input type="checkbox"/> Yes <input type="checkbox"/> No <input type="checkbox"/> N/A
	Secondary (disinfected)	Subsurface and surface irrigation	40 m from the high water level	<input type="checkbox"/> Yes <input type="checkbox"/> No <input type="checkbox"/> N/A

<sup>^</sup> If within 100 metres of a bore or well licenced for domestic consumption\*, viral die-off modelling is required using an appropriate methodology. For examples, see section 6.7 of the Onsite Wastewater Management Guidelines and Cromer, Gardner and Beavers (2001).

\* Domestic consumption is taken to mean for drinking, watering of edible plants etc.

-Where the effluent application system is located downslope of the receiver, justification for a reduced buffer distance may be provided with consideration of factors such as the type of effluent application system, surface and subsurface drainage pathways and adjusted flow paths, and site factors such as soil permeability.

## Drainage

Using gravity for drainage instead of pressured delivery by pump or siphon can limit the effluent management system performance. This must be considered when choosing a system. Wastewater must reach the tank or treatment system and then be evenly distributed. All drainage and plumbing work must be completed according to [AS/NZS 3500.2:2021 Plumbing and drainage Sanitary plumbing and drainage](#). The standard should also be used to decide the position of the system to ensure adequate drainage from internal fixtures to the system.

### Pipe selection and grade

The grade or fall from the tank must be considered when locating a system. Pipe size should also be decided based on the minimum grade needed for adequate drainage. Table 2.9 can be used to select pipe size based on the minimum grade ratio. Where a sewer carrying untreated wastewater to a treatment system is longer than 60 metres, the minimum grade should be doubled and inspection ports should be installed at least every 30 metres or at any change of direction or grade.

**Table 2.9** Minimum pipe diameter calculations

Nominal pipe size (DN)	Minimum grade %	Minimum grade ratio
65	2.5	1:40
80	1.65	1:60
100	1.65*	1:60
125	1.25	1:80
150	1.00	1:100

\* Except for drains from septic tanks, sewage treatment plants and unvented discharge pipes from tundishes, which may have a minimum grade of 1%,  
**Source:** [AS/NZS 3500.2:2021 Plumbing and drainage Sanitary plumbing and drainage](#) (Table 3.4.1) NB: pipe grades are expressed as a percentage of vertical to horizontal distances.

### Minimum depth of drainage pipes

When considering system location, associated pipe work must be able to be buried according to [AS/NZS 3500 Set \(Parts 0-4\):2021 Plumbing and drainage](#). Table 2.10 outlines the minimum pipe depth for trafficable areas, such as under driveways.

The effluent distribution pipe from the tank to the effluent management area must be buried at the applicable depth and in a manner that provides protection against mechanical damage or deformation.

**Table 2.10** Minimum pipe depth for trafficable areas

Location	Minimum depth of cover in millimetres (mm) for all materials other than cast iron
Where subject to vehicular traffic	500
Elsewhere	300

Source: [AS/NZS 3500 Set \(Parts 0-4\):2021 Plumbing and drainage](#). Table 3.7.2 Minimum Cover for Buried Pipes'

### Construction work

For all installations, excavating and disturbing the ground surface will require erosion and sediment controls. These controls must be according to 'Managing Urban Stormwater: Soils and Construction Vol 1 4<sup>th</sup> ed.' (the 'Blue Book') (Landcom, 2004).

Checklist 2.1 Wastewater consultant – system selection and location		
<b>Site Address:</b>		
<b>Owner:</b>		
<b>System Selection</b>		
What does the owner expect from the system?		
Is mains electricity available?	<input type="checkbox"/> Yes	<input type="checkbox"/> No
Will the owner pay for ongoing servicing and maintenance?	<input type="checkbox"/> Yes	<input type="checkbox"/> No
Will the owner be careful about what goes into the system?	<input type="checkbox"/> Yes	<input type="checkbox"/> No <input type="checkbox"/> N/A
Will the owner actively maintain the effluent management areas?	<input type="checkbox"/> Yes	<input type="checkbox"/> No
Is the system for a permanently occupied dwelling or a holiday cottage?	<input type="checkbox"/> Yes	<input type="checkbox"/> No <input type="checkbox"/> N/A
What is the predicted daily wastewater load on the system (Refer Table 2.3)?		L
Is the selected system the right size for the predicted daily wastewater load?	<input type="checkbox"/> Yes	<input type="checkbox"/> No
Has a water and nutrient balance been calculated for the site?	<input type="checkbox"/> Yes	<input type="checkbox"/> No
Is the effluent management method approved for use with a system type suitable for the site and its constraints?	<input type="checkbox"/> Yes	<input type="checkbox"/> No
Does the area experience high rainfall (i.e. more than 1,200mm a year)?	<input type="checkbox"/> Yes	<input type="checkbox"/> No
Does the area experience severe winter frost?	<input type="checkbox"/> Yes	<input type="checkbox"/> No
Is the proposed effluent management method suitable for winter frosts?	<input type="checkbox"/> Yes	<input type="checkbox"/> No <input type="checkbox"/> N/A
Is there sufficient grade from the house to tank? (Refer Table 2.9 – Minimum pipe diameter calculations)	<input type="checkbox"/> Yes	<input type="checkbox"/> No
Vertical distance _____m		
Horizontal distance _____m		
Is there sufficient grade <sup>1</sup> from the tank to the effluent management area? (Refer Table 2.9 – Minimum pipe diameter calculations)	<input type="checkbox"/> Yes	<input type="checkbox"/> No
Vertical distance _____m		
Horizontal distance _____m		

Checklist 2.1 Wastewater consultant – system selection and location (continued)	
If not, will a tank riser be needed?	<input type="checkbox"/> Yes <input type="checkbox"/> No
What size riser is needed to give sufficient grade?	mm
Will treated effluent need a pump or other low pressure dosing device to distribute it?	<input type="checkbox"/> Yes <input type="checkbox"/> No <input type="checkbox"/> N/A
If so, what size and other pump characteristics are needed?	
Is there enough area available to apply effluent as needed for hydraulic /nutrient assimilation?	<input type="checkbox"/> Yes <input type="checkbox"/> No
Does the proposed effluent management area meet the NSW Division of Local Government and WaterNSW requirements <sup>2</sup> for buffer distance setbacks? (Refer Table 2.8)	<input type="checkbox"/> Yes <input type="checkbox"/> No
Does stormwater and upslope run-on need to be diverted away from the effluent management area <sup>2</sup> ?	<input type="checkbox"/> Yes <input type="checkbox"/> No
Will the sewer pipe and the effluent distribution pipe be affected by any paths or driveways that will influence minimum burial depth? (Refer Table 2.10)	<input type="checkbox"/> Yes <input type="checkbox"/> No
Type, model name and number of chosen system (including pump details if non-standard)	
Based on the above questions does the chosen system meet the above needs and site constraints?	<input type="checkbox"/> Yes <input type="checkbox"/> No
<b>Comments<sup>3</sup>:</b>	
<p><sup>1</sup> For passive systems only. For systems on a site with no grade, a pump will be required.</p> <p><sup>2</sup> All run-on and stormwater collected from roofs and other hard surface areas must be diverted away from the effluent management area e.g. via a stabilised berm or drain that allows energy dissipation at the outlet to prevent scouring or erosion.</p> <p><sup>3</sup> Where a response to this checklist needs more information or action, specify the action plan and/or the process to fix the problem, or specify the alternative being offered.</p>	

## 2.5 Case study

An aerated wastewater treatment system was installed on a constrained site and a number of effluent irrigation areas were dedicated for effluent management. When installing the irrigation lines, the contractor ran the main distribution pipe under a driveway to reach the effluent irrigation area (Figure 2.2). Several days after commissioning the system, a delivery truck drove onto the driveway, and within days of the truck movements, effluent began surfacing in the driveway area.

### Problem

When the contractor returned to investigate the problem, he found the pipe below the driveway was cracked and effluent was leaking from the pipe and not reaching the effluent irrigation area. The pipe had been buried so that it was only covered by about 50 millimetres of gravel.

### Solution

When running irrigation pipe under trafficable areas, the pipework should be protected to the same specification as a sewer or stormwater pipe according to [AS/NZS 3500.1:2021 Plumbing and drainage Water services](#). The Standard recommends that pipes under a driveway with vehicular traffic should be buried at least 500 millimetres underground and in a manner that provides protection against mechanical damage or deformation, unless the product specification states otherwise (see Table 2.10).



**Figure 2.2** Main irrigation line buried at only 50mm under gravel driveway – 500mm is the minimum required depth.

### 3 Septic Tanks

A septic tank provides the primary treatment of wastewater from a dwelling. It is often used together with other treatment measures such as an aerated wastewater treatment system or with a pump well that pumps the clarified primary treated effluent for disposal. Primary treatment in a septic tank involves the following mainly physical (but also some chemical and biological) processes, which are further described below:

- sedimentation (solids)
- flotation (scum)
- clarification
- anaerobic digestion (organic material breakdown).

A septic tank must be able to retain at least the maximum 24-hour design flow to optimise settling and moderate peak flows. A correctly sized septic tank can remove approximately 25 to 35% of the Biochemical Oxygen Demand (BOD<sub>5</sub>) load and more than 60% of the suspended solids load from raw wastewater. Solids are stored in the base of the primary tank and liquids are discharged for further treatment and/or disposal. Floating material (scum) typically accumulates on the surface providing an airtight seal creating anaerobic conditions. Figure 3.1 shows a typical cross section of a septic tank.

#### **Sedimentation**

Sedimentation is achieved by settling in the still tank and is helped by the flocculation of suspended particles into larger aggregates. Sludge collects at the base of the tank. While a long flow path in the tank from inlet to outlet helps with sedimentation, tanks with shorter flow paths may be baffled. The baffles will help keep the settled solids upstream of the baffle and create a still zone downstream to further help with settling before discharge. It is better for inflow to the tank to be gentle to avoid disturbing already settled solids. This is achieved by avoiding surge flows or having steep gradients from the source to the tank, and by fitting an inlet tee to moderate flow at the entry to the tank.

#### **Flotation**

Residues (oils and grease, surfactants, other low-density materials) rise to the surface of the tank and form a scum layer. Scum is kept in the tank by the inverted outlet pipe or baffle. The scum layer helps create an anaerobic environment for organic solids to breakdown.

#### **Clarification**

Settled wastewater is kept in the middle layer of the tank. Tanks are appropriately sized to allow for maximum solids settling. Effluent is drawn from the clarified liquid between the sludge and scum layers for further treatment and/or disposal.

#### **Anaerobic digestion**

Anaerobic microbes break down the accumulated organic material at the base of the tank. Organic material is converted to stable compounds and gases (e.g. carbon dioxide, methane and hydrogen sulphide). The retained sludge is mainly ligneous material that is difficult to decompose and will continue to accumulate. It will need to be removed every three to five years.

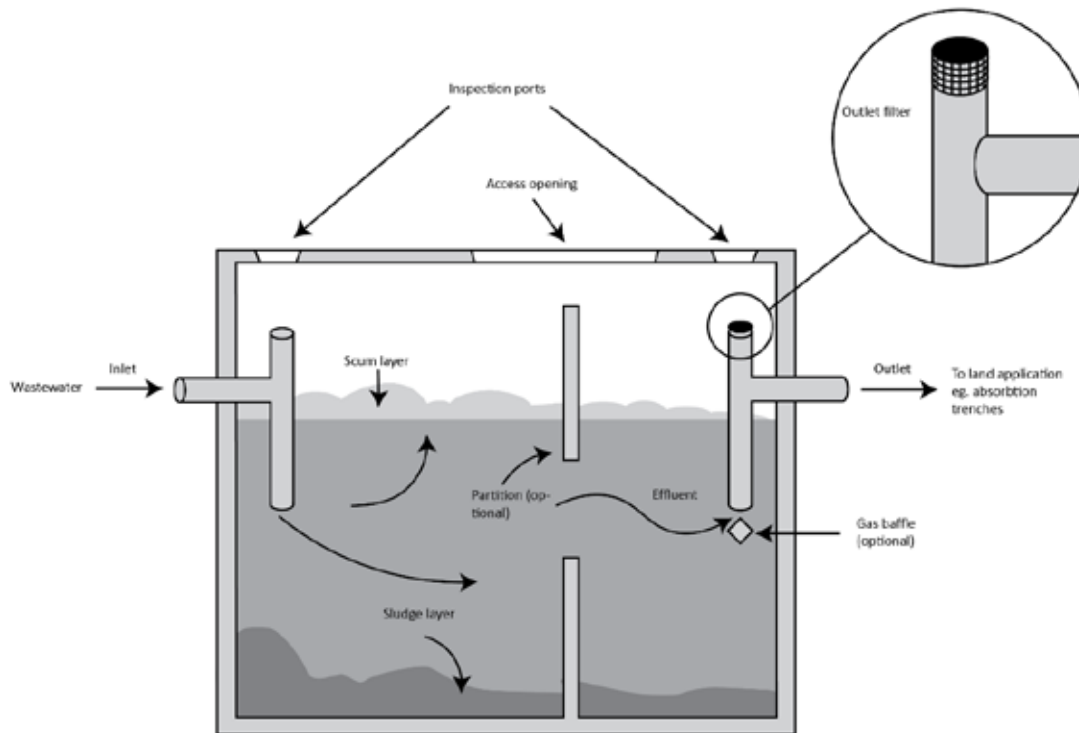

Figure 3.1 Cross section of a typical septic tank (Ref: AS/NZS1546.1:2008)

### 3.1 Design

Septic tanks must be designed according to '[AS/NZS 1546.1:2008 On-site domestic wastewater treatment units – Septic tanks](#)'. In NSW, any proprietary septic tank under 10,000 litres must be accredited by NSW Health. Larger tanks may be designed and constructed on-site but they must comply with [AS/NZS 1546.1:2008](#). NSW Health requires all tanks more than 2,050 litres to be baffled. Septic tanks should include an outlet filter. Accredited tanks are listed on the NSW Health website.

[www.health.nsw.gov.au/environment/domesticwastewater](http://www.health.nsw.gov.au/environment/domesticwastewater)

#### Sizing

A septic tank must have capacity to hold the peak daily hydraulic load for at least 24 hours plus an allowance for accumulated sludge. A tank that is too small could allow solids to pass on to the next treatment phase. WaterNSW requires at least a 3,000-litre tank in almost all circumstances. This may be increased according to the number of bedrooms in a proposed dwelling, or where the dwelling includes a spa bath. For sizing, refer to [AS/NZS 1547:2012 On-site domestic wastewater management](#).

#### Site considerations

When choosing the tank location, you must consider the various site constraints such as slope and stability. A septic tank must be positioned on a stable, level base. A septic tank on a sloping site may need a stormwater diversion drain to prevent stormwater inundation. It may also need a pump well to pump effluent from the tank to an upslope effluent management area.

#### Tank location

The location of a tank should be decided in consultation with the licensed plumber. It will depend on the fall (grade/slope) and drainage outlets needed from the dwelling. Some constrained sites may need to locate tanks under driveways and other structures, such as decks and patios. In

these cases, the manufacturer can provide a maximum load rating for the tank and a structural engineer must be consulted to ensure the tank has the structural capacity to handle the anticipated vertical load.

## 3.2 Installation

Septic tank installation must comply with the manufacturer's recommendations, [AS/NZS 3500.2:2021 Plumbing and drainage Sanitary plumbing and drainage](#) and Council requirements. Checklist 3.1 helps system installers and council inspectors ensure the septic tank has been correctly installed. The following extra steps provide details not included in the checklist.

### **Step 1**                    **Transporting tanks**

All proprietary tanks should be manufactured and transported to the installation site as one complete unit to preserve their structural integrity. Tank manufacturers can recommend suitable transport methods based on the tank type. Tanks should be kept upright and not laid on their side.

### **Step 2**                    **Lifting and moving tanks**

All tanks should only be lifted or moved using the lifting points shown on the outside of the tank. Tanks should not be lifted by the rim or lid/inspection holes. Do not use a forklift unless the lift arms reach completely underneath the tank to support the base.

### **Step 3**                    **Excavating and preparing the hole for tanks**

The depth of the hole for the tank depends on the fall of the pipe to the tank and the distance from the installed tank to the wastewater source. The tank should be installed so that the lid remains at least 100 millimetres above final ground level to stop stormwater entering the tank. The hole must be clear of roots and foreign matter. The excavation must allow space to fix tank anchors as per the manufacturer's recommendations, if required. The base of the hole must have a clean bed of compacted sand at least 50 millimetres deep. The sand surface must be flat and level.

### **Step 4**                    **Installing tanks**

Tanks should be carefully lowered into the hole and not dropped. Use lifting equipment to adjust the position of the tank. The tank inlet should be in line with the inlet pipes.

### **Step 5**                    **Connecting pipes and fittings**

Connect the tank inlet to the inlet pipe using a 100 millimetre rubber sleeve and secure it according to plumbing practices detailed in [AS/NZS 3500 Set \(Parts 0-4\):2021 Plumbing and drainage](#) and the manufacturer's recommendations. Methods to secure pipe work into inlets and outlets vary with the different tanks, which may include concrete, fibreglass or polyethylene.

### **Step 6**                    **Sealing pipes and lids**

Tank lids and inlet and outlet connections should be sealed with an appropriate durable and flexible sealant to avoid stormwater entering the tank.

### **Step 7**                    **Drainage**

If stormwater or groundwater cannot adequately drain away from the tank hole, then the tank could move resulting in failed or broken pipes and connections and/or the tank lifting completely out of the ground. Infiltrated stormwater and/or groundwater should be drained from around the tank using agricultural (Ag) pipe (Figure 3.2) and a free draining backfill. If this is not possible because there is not enough fall for the water to exit the pipes, the tank may need to be anchored (Step 8).

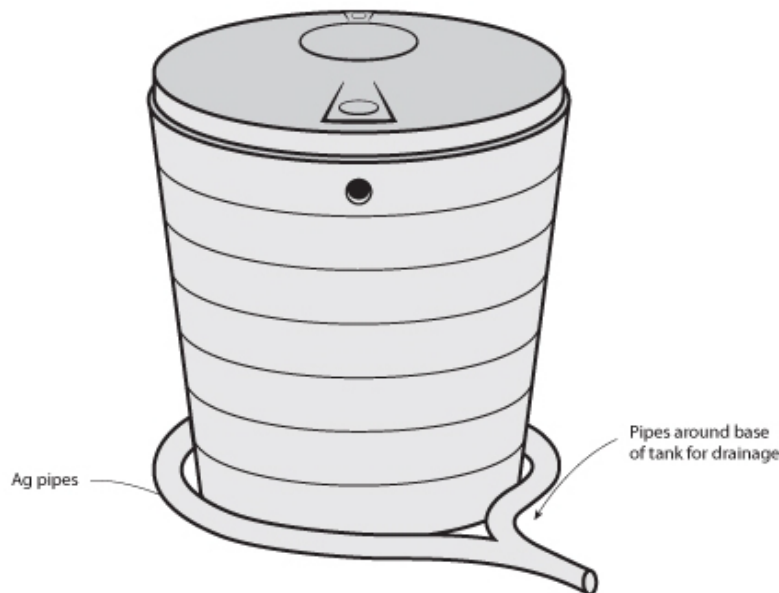

**Figure 3.2** Ag pipes around base of septic tank for drainage

On sloping sites and sites with high surface water flows, stormwater diversion devices may be needed to prevent ponding and pooling around the top of the installed tank. A surface drainage berm to divert surface water runoff from pooling around the tank can be built using mounded soil before vegetating (see Figure 3.3).

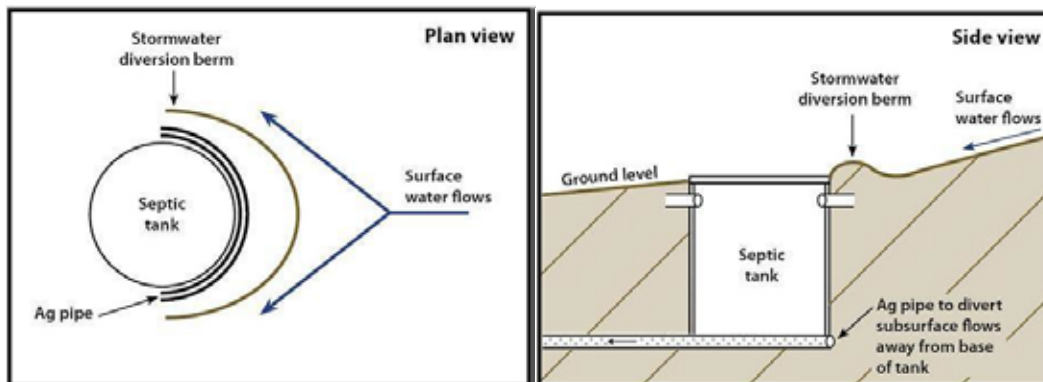

**Figure 3.3** Tank stormwater drainage design

**Step 8** *Attaching ground anchors (if required)*

If groundwater levels are high and/or drainage cannot be installed, ground anchors may be needed (Figure 3.4). The size and installation of ground anchors must comply with [‘AS/NZS 1546.1:2008 On-site domestic wastewater treatment units – Septic tanks, section 3.2.2 Anchorage.’](#)

Loops connecting the anchors to the tank must be fitted when the tank is installed. Each side of the tank must be anchored using a piece of filled pipe attached to the tank by durable ties made from stainless steel cable. These ties are fitted to the anchor points on the tank and have a loop in the other end at excavation base level.

Backfilling covers the anchors securing the tank in the ground. To prepare ground anchors you must:

- fill the ground anchors (100 millimetre uPVC sewer pipe) with sand and cap the ends. Attach at least two anchors to a tank, parallel to each other, on opposite sides of the tank. Use more anchors if the soil is prone to saturation. The anchors should be at least as long as the diameter of the tank
- secure the free end loops of cable around the ends of each ground anchor, with two cables to each anchor
- fit a stainless steel shackle in each cable through pre-drilled holes in vertical ribs of each tank and secure
- hang all ground anchors level beside the tank approximately 150 millimetres from the bottom of the excavation, with cables fully secured and all fastenings securely tightened. Sand filled anchors help tighten the cables and ensure maximum effect. Never run cables through the anchor pipes as they will cut when under loads.

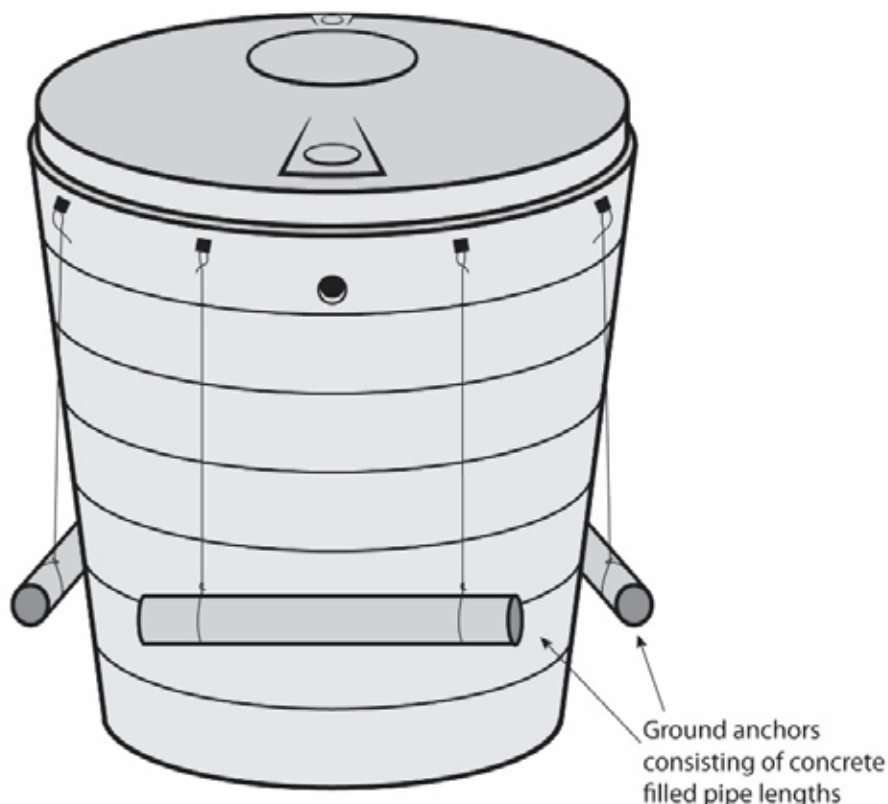

Figure 3.4 Ground anchors

Alternatively, a **hydrostatic flange and anchor collar** may be fitted. An 'L' shaped anchor collar section at least 65 millimetres wide and 6 millimetres thick should be built and fixed to the outside circumference of the tank with durable material protected from corrosion. The collar can be continuous around the circumference or in at least two sections each at least 600 millimetres long and fixed on opposite sides of the tank. For a vertical cylindrical tank, the flange is fixed less than 300 millimetres from the base. For a horizontal cylindrical tank, the flange is situated along the line of the greatest horizontal perimeter.

## **Wet Ground Install**

The hole is to be excavated while using spear points or vortex pumps to lower the ground water level. A minimum of 2m<sup>3</sup> 20MPa concrete is required to provide ballast to a 3,000 litre poly tank with a 1.6m<sup>3</sup> bed. A 100mm thick concrete base with S72 mesh reinforcing is poured in the excavation and made level. The tank – with eight anchor points and four sand filled pipe ground anchors – is then placed on the wet concrete and levelled. The tank is then filled with water and the remaining concrete is then poured around the tank evenly, not exceeding the depth of the water ballast in the tank. This fully encapsulates the base preventing any pressure being applied to the base.

### **Step 9            Backfill**

Do not start backfilling until connections and anchoring are all complete. Some regulatory authorities require an inspection before backfilling.

### **Step 10 Vegetation**

The area around the tanks should be suitably vegetated with non-invasive plant species. Some plants can penetrate even a sealed tank and pipe work. Planting suitable species around a tank, particularly on sloping sites, is important to minimise soil erosion from the excavated area around the tanks.

Checklist 3.1 outlines a comprehensive range of items to inspect for new septic tank installations. Councils and installers can use the checklist as part of their installation report. Installation checklists for effluent management systems are in Sections 8 (Amended soil mounds), 9 (Sand mounds), 10 (Absorption trenches and beds), 11 (Evapotranspiration absorption beds), 12 (Surface irrigation) and 13 (Subsurface irrigation).

**Checklist 3.1 Septic tank installation inspection for installers and Council inspectors**

(Based on 'Consortium of Institutes for Decentralised Wastewater Treatment – Installation Checklists', Iowa State University, Midwest Plan Service. Ames, IA)

Owners name:

Address:

Tank coordinates:

Installation date:

**Type of tank** (tick all applicable e.g. septic tank plus pump well. NB: where the system involves a septic tank and a pump well, WaterNSW supports a minimum 3-day pump well capacity based on design load.)

<input type="checkbox"/> Septic tank	<input type="checkbox"/> Pump well	<input type="checkbox"/> Collection / holding well	<input type="checkbox"/> Other
--------------------------------------	------------------------------------	--	--------------------------------

Tank No.

Tank No.

Tank No.

Manufacturer (Tank 1):

Model #:

Material:

 Plastic/poly    Concrete    Fibreglass    Other

Comment:

Manufacturer (Tank 2):

Model #:

Material:

 Plastic/poly    Concrete    Fibreglass    Other

Comment:

**Specified or calculated tank capacity of each tank**

(1)

L

(2)

L

**Tank dimensions (as provided on manufacturer's design specification sheet)**

	Tank (1)	Tank (2)
Exterior dimensions (diameter & height)	mm	mm
Interior dimensions	mm	mm
Exterior height of inlet invert	mm	mm
Exterior height of outlet invert	mm	mm
Effective depth	mm	mm

**Tank seam**Location:    N/A    Mid    Top

Comment:

<b>Checklist 3.1 continued</b>				
Has the tank been appropriately sealed?				
<input type="checkbox"/> Butylmastic	<input type="checkbox"/> Butyl tape wrap	<input type="checkbox"/> Two-part epoxy	<input type="checkbox"/> Two-part epoxy and stainless fasteners	<input type="checkbox"/> Other
Tank structural integrity verified before setting	<input type="checkbox"/> Yes	<input type="checkbox"/> No	<input type="checkbox"/> N/A	
<b>Excavation / setting tanks</b>				
Location of tanks:				
Verify required inlet / outlet elevations	<input type="checkbox"/> Yes	<input type="checkbox"/> No	<input type="checkbox"/> N/A	
Groundwater present in excavation	<input type="checkbox"/> Yes	<input type="checkbox"/> No	<input type="checkbox"/> N/A	
Dewatering performed	<input type="checkbox"/> Yes	<input type="checkbox"/> No	<input type="checkbox"/> N/A	
<b>Bottom of excavation</b>				
Level	<input type="checkbox"/> Yes	<input type="checkbox"/> No	<input type="checkbox"/> N/A	
Free of rock and debris	<input type="checkbox"/> Yes	<input type="checkbox"/> No	<input type="checkbox"/> N/A	
<b>Bedding material</b>				
Description:				
Depth:	cm			
Free of large rocks, debris	<input type="checkbox"/> Yes	<input type="checkbox"/> No	<input type="checkbox"/> N/A	
Levelled and compacted	<input type="checkbox"/> Yes	<input type="checkbox"/> No	<input type="checkbox"/> N/A	
<b>Structural integrity of tanks verified</b>				
Tank installed level	<input type="checkbox"/> Yes	<input type="checkbox"/> No	<input type="checkbox"/> N/A	
Tank oriented correctly	<input type="checkbox"/> Yes	<input type="checkbox"/> No	<input type="checkbox"/> N/A	
<b>Free standing above ground</b>				
Flat bed	<input type="checkbox"/> Yes	<input type="checkbox"/> No	<input type="checkbox"/> N/A	
Levelled and compacted	<input type="checkbox"/> Yes	<input type="checkbox"/> No	<input type="checkbox"/> N/A	
Verify required inlet and outlet elevations	<input type="checkbox"/> Yes	<input type="checkbox"/> No	<input type="checkbox"/> N/A	
<b>Flotation prevention</b>				
Buoyancy calculations provided on design	<input type="checkbox"/> Yes	<input type="checkbox"/> No	<input type="checkbox"/> N/A	
<b>Anti-flotation implemented</b>				
Tank collar	<input type="checkbox"/> Yes	<input type="checkbox"/> No	<input type="checkbox"/> N/A	
Anchor weight	<input type="checkbox"/> Yes	<input type="checkbox"/> No	<input type="checkbox"/> N/A	
Other / Comment:				

<b>Checklist 3.1 continued</b>			
<b>Backfill</b>			
Backfill material:			
Compacted	<input type="checkbox"/> Yes	<input type="checkbox"/> No	<input type="checkbox"/> N/A
Free of debris and large rocks	<input type="checkbox"/> Yes	<input type="checkbox"/> No	<input type="checkbox"/> N/A
<b>Piping</b>			
Piping in appropriate sequence (inlet/outlet)	<input type="checkbox"/> Yes	<input type="checkbox"/> No	<input type="checkbox"/> N/A
Inlet:	mm	Outlet / supply line:	mm
<b>Pipe specifications (material and nominal diameter)</b>			
Return line:	mm	Electrical conduit:	mm
Joints in excavated area	<input type="checkbox"/> Yes	<input type="checkbox"/> No	<input type="checkbox"/> N/A
<b>Pipe sealing</b>			
Pipes appropriately sealed (including electrical conduit for pump well)	<input type="checkbox"/> Yes	<input type="checkbox"/> No	<input type="checkbox"/> N/A
Type of sealant	Inlet:		
	Outlet / supply line:		
	Return line (if installed):		
	Electrical conduit:		
Recirculation device	<input type="checkbox"/> Yes	<input type="checkbox"/> No	<input type="checkbox"/> N/A
Type of recirculation device:			
<b>Baffles / compartments</b>			
Inlet baffle type:			
Outlet baffle type:			
Effluent screen model # and manufacturer:			
Types of baffles:	<input type="checkbox"/> Poly/Plastic	<input type="checkbox"/> Concrete	<input type="checkbox"/> Fibreglass
Installation by:	<input type="checkbox"/> Manufacturer	<input type="checkbox"/> Contractor	
Verify air passage	<input type="checkbox"/> Yes	<input type="checkbox"/> No	<input type="checkbox"/> N/A
<b>Tank access &amp; venting</b>			
Access location and size	Inlet:		mm
	Outlet:		mm
	Centre:		mm
Access risers required	<input type="checkbox"/> Yes	<input type="checkbox"/> No	
Sealant used in tank / riser connections	<input type="checkbox"/> Yes	<input type="checkbox"/> No	
Venting	<input type="checkbox"/> Yes	<input type="checkbox"/> No	<input type="checkbox"/> N/A
Through plumbing stack	<input type="checkbox"/> Yes	<input type="checkbox"/> No	<input type="checkbox"/> N/A
Tank vent (describe):			

Checklist 3.1 continued	
Proprietary filter	<input type="checkbox"/> Yes <input type="checkbox"/> No <input type="checkbox"/> N/A
Filter manufacturer and model #:	
Tank water tightness testing	<input type="checkbox"/> Yes <input type="checkbox"/> No <input type="checkbox"/> N/A
<b>Comments, actions or repairs required:</b> (Where a response in this checklist needs extra information or action, specify the action plan and/or the process to fix the problem, or specify an alternative that is being offered)	
<p><b>Service provider:</b></p> <p><b>Title:</b></p> <p><b>Contact number:</b></p>	
<b>Signature:</b>	<b>Date:</b>

### 3.3 Testing

#### Pumps

Where pumps are used in a separate external pump well or an internal pump chamber, they should be clean water tested before commissioning to ensure they achieve the desired head for the proposed operation.

#### Water tightness

All joints should be sealed with flexible sealant according to the manufacturer's instructions to ensure water tightness. Secure the septic tank lid and inspection openings to provide a watertight seal.

### 3.4 Inspection

Council should inspect the tank and all associated pipe and drainage work before backfilling to ensure all components are correctly positioned and installed according to [ABCB National Construction Code \(NCC\) Series Volume Three – Plumbing Code of Australia](#) (Commonwealth of Australia, and the States and Territories of Australia 2022, published by the Australian Building Codes Board). Council should make a final installation inspection to ensure the system complies with all consent conditions before issuing an approval to operate the system. Checklist 3.2 provides a list of items to inspect for operating septic systems that council inspectors and system owners can use to ensure their system continually operates as required.

### 3.5 Operation

#### Pumps

Different system designs can use different types of pumps. The most common are surface mounted pumps with an inlet in a separate pump well. These systems pump the clarified primary effluent, with minimal solids, to an effluent management area. Where a collection well is used with a pump-to-sewer system, there will be a grinder or macerator pump in the septic chamber of the tank. These pumps are designed to pump both liquid and solids to a secondary treatment system.

Do not use a macerator or grinder pump to transfer effluent directly from a septic tank to an effluent management area, as the latter will block and fail due to the solid content in the effluent.

#### Outlet filter

The outlet filter should be inspected every three months and cleaned when necessary. Clean the outlet filter by removing it from the outlet, placing it in the inlet and agitating to remove gross solids, or by hosing it off (Figure 3.5), ideally, into a bucket or directly into the septic tank. It is important to only hose off gross solids and not the biofilm that accumulates on filter surfaces. The filter does not need to be completely clean. It is preferable to avoid disturbing the crust on the septic tank when cleaning the outlet filter.

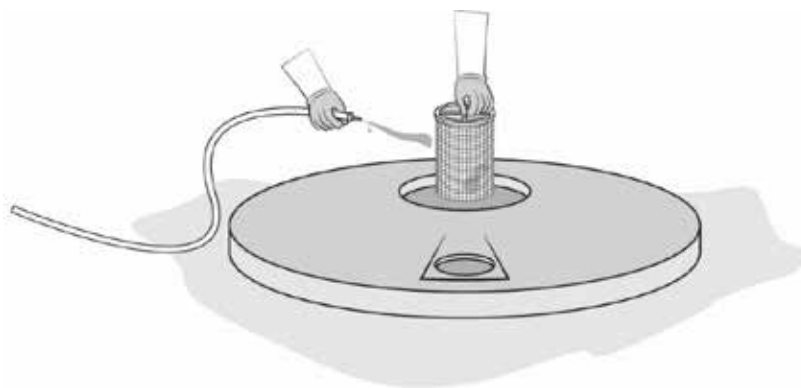

Figure 3.5 Cleaning the outlet filter

## Desludging

Sludge levels in septic tanks should be inspected regularly as part of the maintenance schedule and the sludge depth measured with an appropriate device (e.g. "Sludge Depth Indicator") See Figure 3.6.



**Figure 3.6** 'Sludge Depth Indicator' (Source: Centre for Environmental Training, 2019)

[AS/NZS 1547:2012 On-site domestic wastewater management](#) provides guidance about how often to remove sludge (roughly once every three to five years). A licensed contractor should remove the sludge. When sludge is removed from a septic tank, about 10% of the original contents should be kept in the tank to help an appropriate bacterial population regenerate for ongoing treatment.

Once pumped out, the tank should be refilled with water to its normal operating level to protect against undue upward pressure from high groundwater. If the groundwater level near the tank is known to be high, solids should be pumped from the tank at the same time as refilling it with clean water. Once pumped out, replace all inspection openings and seal the tank lid with flexible sealant.

<b>Checklist 3.2 Operating septic system inspection for Council inspectors</b>			
Owners name:			
Address:			
Installation Date:			
Tank coordinates:		Effluent management area coordinates:	
Slope:	%	Tank diameter:	mm
Water source:	<input type="checkbox"/> Tank <input type="checkbox"/> Bore/reticulated	Nearest watercourse:	m
No. of residents:		No. of tanks:	
No. of bedrooms:		Tank volume(s):	L
System age:		Nearest house:	m
Is there vegetation present?		<input type="checkbox"/> Yes	<input type="checkbox"/> No
Is there native vegetation dieback?		<input type="checkbox"/> Yes	<input type="checkbox"/> No
Do you need to remove vegetation around and in the tank to improve access for maintenance?		<input type="checkbox"/> Yes	<input type="checkbox"/> No
Is there weed infestation?		<input type="checkbox"/> Yes	<input type="checkbox"/> No
Is there localised flood potential?		<input type="checkbox"/> Yes	<input type="checkbox"/> No
Is there erosion potential?		<input type="checkbox"/> Yes	<input type="checkbox"/> No
<b>Tank</b>			
Is there any indication of cracks, staining or leaks around the perimeter of the septic tank and/or pump well and/or holding tank?		<input type="checkbox"/> Yes	<input type="checkbox"/> No
Are there any gaps between the tank and the lid?		<input type="checkbox"/> Yes	<input type="checkbox"/> No
Is the tank lid suitable for the tank?		<input type="checkbox"/> Yes	<input type="checkbox"/> No
Does the tank have easily accessible inspection caps?		<input type="checkbox"/> Yes	<input type="checkbox"/> No
Are the inspection caps present and unbroken?		<input type="checkbox"/> Yes	<input type="checkbox"/> No
Has the primary septic tank been de-sludged in the last 5 years?		<input type="checkbox"/> Yes	<input type="checkbox"/> No <input type="checkbox"/> Unknown
Does the tank need desludging (is the sludge level high or near the bottom of the inlet)?		<input type="checkbox"/> Yes	<input type="checkbox"/> No
Is any air vent attached to the septic tank / holding well in a functional state?		<input type="checkbox"/> Yes	<input type="checkbox"/> No <input type="checkbox"/> N/A
Is the tank in good condition (no cracks, leaks / damaged lids/ walls)?		<input type="checkbox"/> Yes	<input type="checkbox"/> No
Do tanks need urgent repair / replacement due to major structural failure or undersizing?		<input type="checkbox"/> Yes	<input type="checkbox"/> No
Does the tank have a scum or crust layer?		<input type="checkbox"/> Yes	<input type="checkbox"/> No
Has the outlet filter been cleaned recently?		<input type="checkbox"/> Yes	<input type="checkbox"/> No <input type="checkbox"/> N/A

<b>Checklist 3.2 continued</b>			
<b>Pumps</b>			
Does the pump operate when needed? (trigger the float switch(es) to check operation)	<input type="checkbox"/> Yes	<input type="checkbox"/> No	<input type="checkbox"/> N/A
Does the alarm work?	<input type="checkbox"/> Yes	<input type="checkbox"/> No	<input type="checkbox"/> N/A
Has the pump been serviced in the last 12 months?	<input type="checkbox"/> Yes	<input type="checkbox"/> No	<input type="checkbox"/> N/A
<b>Pipes</b>			
Are the pipes connecting the septic tank, pump well and/or holding well, or septic tank and trench, functioning and installed correctly?	<input type="checkbox"/> Yes	<input type="checkbox"/> No	<input type="checkbox"/> Unknown
Are there any unsealed pipes that allow untreated wastewater to escape?	<input type="checkbox"/> Yes	<input type="checkbox"/> No	<input type="checkbox"/> Unknown
<b>Comments, actions or repairs required:</b> (Where a response in this checklist needs extra information or action, specify the action plan and/or the process to fix the problem, or specify an alternative that is being offered)			
<b>Service provider:</b>  <b>Title:</b>  <b>Contact number:</b>			
<b>Signature:</b>		<b>Date:</b>	

### 3.6 Common technical issues

There are a number of common problems with septic tank installations including:

- not installed as per the approved design and specification
- tanks rising out of the ground after rainfall - this is most common for un-anchored plastic or fibreglass tanks
- baffles and inlet and outlet junctions removed, not installed, broken, or not connected to an effluent management system (Figure 3.7)
- pumping from the septic tank rather a separate pump well
- high levels of sludge accumulating due to inadequate maintenance (lack of desludging)
- undersized tanks relative to the hydraulic loads
- poor drainage around the tank due to run-on, or because it is installed too low into the ground.



**Figure 3.7** Outlet pipe discharging directly onto open ground

### 3.7 Case study

A septic tank and pump well were installed on a site prone to high groundwater levels. After significant rain the property owner noticed that the pump well was sitting higher out of the ground than when installed. The owner put some fill around the tank and thought it would be alright. A month later a council officer inspected the tanks and noticed the same tank sitting high out of the ground with ponded effluent and soggy ground around it (Figure 3.8).



Figure 3.8 Tank that has lifted due to high water table

#### Problem

The tanks were installed without adequate drainage or ground anchors. During wet weather the pump well, which was almost empty, became buoyant and started to float. With the surrounding groundwater pressure, the tank lifted from its original position in the hole. The tank movement caused the inlet and outlet pipes to crack and break resulting in continual discharge of effluent around the tanks. When the tanks were installed, the installer did not follow the manufacturer's recommendation to install ground anchors and the tanks were not adequately secured in the ground. The tanks were also backfilled with clay material that did not allow enough drainage around the tank and installed in a slight depression in the land that directed stormwater to the area around the tanks.

#### Solution

Dig out around the tank and install the ground anchors as recommended by the tank manufacturer. Repair the connections. Backfill around the tanks with free draining soil or sand to ensure sufficient drainage. Install stormwater surface diversion drains around the top of the tanks. Alternatively, remove the tanks from the drainage depression and relocate them to a more suitable location on the property, again using ground anchors and free draining soil for backfilling.

## 4 Aerated Wastewater Treatment Systems

An Aerated Wastewater Treatment System (AWTS) uses aerobic treatment to promote oxidation and microbiological consumption of organic matter by bacteria through facilitated biological processes. Given enough oxygen and time, aerobic microbes (e.g. bacteria, protozoa) break down organic matter through respiration. Figure 4.1 shows the schematic operation of an AWTS.

### Aeration and nitrogen

Aerobic processes encourage specific bacteria to convert organic nitrogen and ammonia to nitrate (nitrification). Oxygen is supplied to the aeration chamber by a pump (blower) and air diffusers, or mechanical mixing / movement of the effluent, or trickling effluent over porous material (passive). Aerobic chambers are sized to ensure endogenous respiration occurs, limiting the population and avoiding the need for larger aerobic chambers. Over time, dead cell mass and residuals will collect in the chamber and eventually need to be removed.

Aerobic treatment can be affected by variation in hydraulic and organic loads. Intermittent or low loads can affect the system performance. Air supply and sludge return systems need regular monitoring and adjustment to ensure the best system performance. Experience with AWTSs show that these factors constantly change and the system cannot be left 'as installed'. Factors that will affect aerobic treatment are:

- volume / rate / timing of oxygen supply
- food / microorganism (F/M) ratio
- temperature
- pH
- sludge return ratios and wasting (sludge age).

### Clarification

Clarification allows aerobically treated effluent and solids to settle by providing still conditions. Many clarification chambers use a funnel (Imhoff) design to concentrate settled sludge and minimise re-suspension. The collected sludge is either recirculated to the aeration chamber or wasted (pumped out). Wasted sludge is usually directed to the primary chamber but eventually accumulated sludge will require removal by pump-out.

### Disinfection

Disinfection removes disease-causing organisms from the wastewater stream. In NSW (and most States) you must have a disinfection system for AWTS if treated effluent will be irrigated on the surface or shallow subsurface. Disinfection usually involves either chlorination using chlorine tablets in an erosion feeder (most common), or ultraviolet (UV) irradiation.

Chlorine is harsh on metal components such as mechanical seals and impellers and can very quickly degrade them. For treatment systems that use chlorine disinfection, the pump should be made from materials that will not be damaged by the corrosive chlorine.

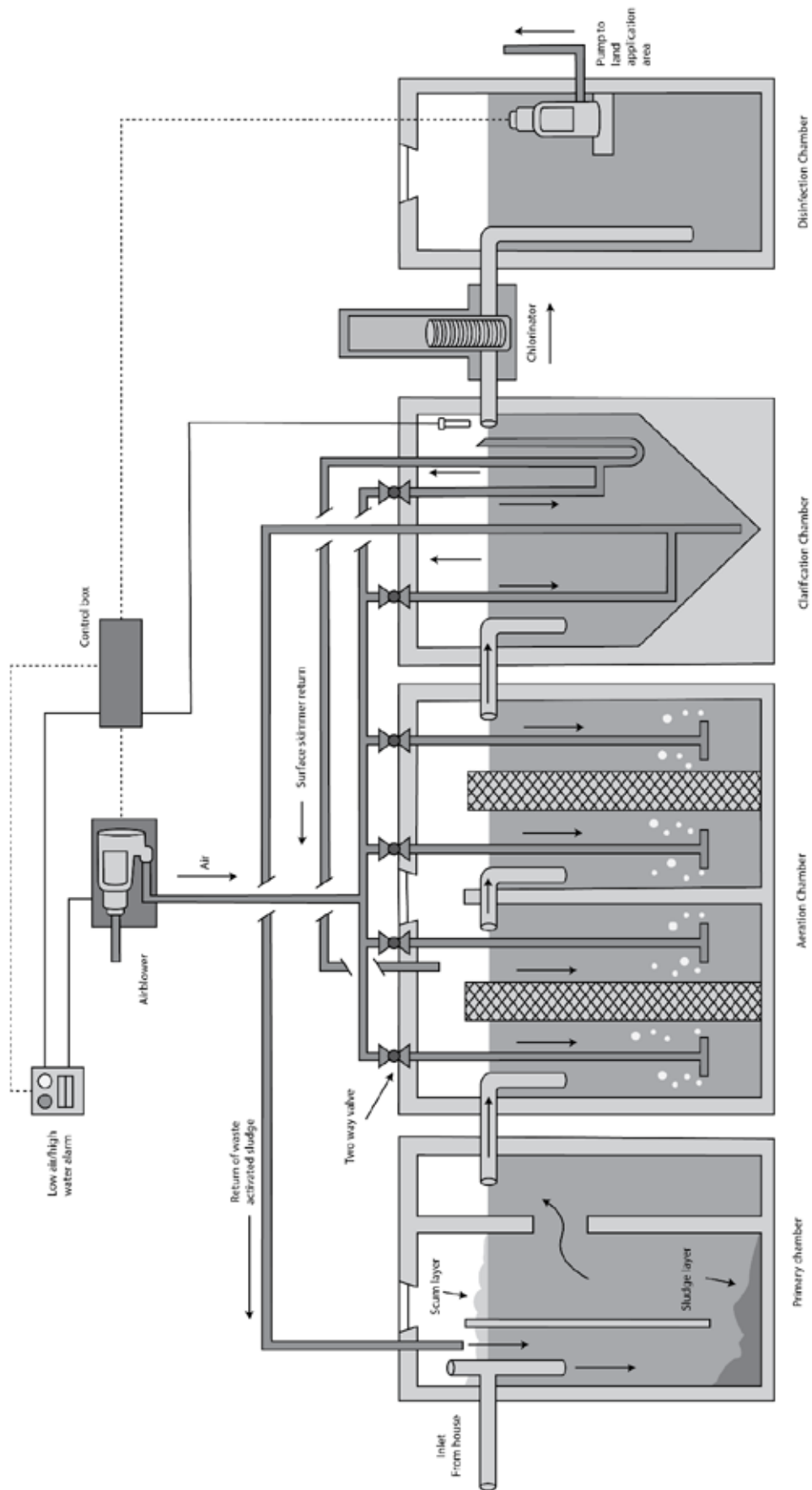

Figure 4.1 Typical schematic of an AWTS Design

## System selection

All domestic AWTSS installed in NSW must be accredited by NSW Health. A regulatory authority cannot approve the installation of a non-accredited system. Accredited AWTSS are listed on the NSW Health website at:

[www.health.nsw.gov.au/environment/domesticwastewater](http://www.health.nsw.gov.au/environment/domesticwastewater)

You must select a system that is suitable for the proposed use. All systems have features that can be beneficial or problematic if installed on certain sites. Things to consider when selecting a system include:

- the daily wastewater load – AWTSS can have various capabilities to accommodate different sized daily wastewater loads. The system chosen must consider these daily wastewater loads and be sized accordingly
- the system location – issues include distance from the house, gravity drainage, and proximity to other structures
- proximity to the effluent management area – this influences the pump size and where to run irrigation mains.

Irrigation hoses and sprinklers provided with some new AWTSS are not acceptable for use in the Sydney drinking water catchment. In such cases, adequate supplementary hosing and sprinklers must be installed.

### Membrane filter AWTSS

Membrane filter AWTSS use aeration, recycling and membrane filtration to produce a very high-quality effluent. Effluent is forced through a membrane with very small pores that separate suspended solids and microorganisms from treated effluent. Membranes are cleaned by low flux operation, air scouring by bubbling, intermittent operation or backwashing.

While membrane filtration processes possess some disinfection capacity, the pore size of a membrane filter dictates its capacity for wastewater constituent removal. Microfiltration typically removes some bacteria, but not viruses or dissolved salts (On-Site Wastewater Management Guidelines, OLG 2025).

### Design flow chart

When choosing an AWTSS, carefully consider daily wastewater loads and site and soil constraints to ensure sustainable effluent application with a neutral or beneficial effect on water quality. Figure 4.2 shows the minimum steps to take in AWTSS design.

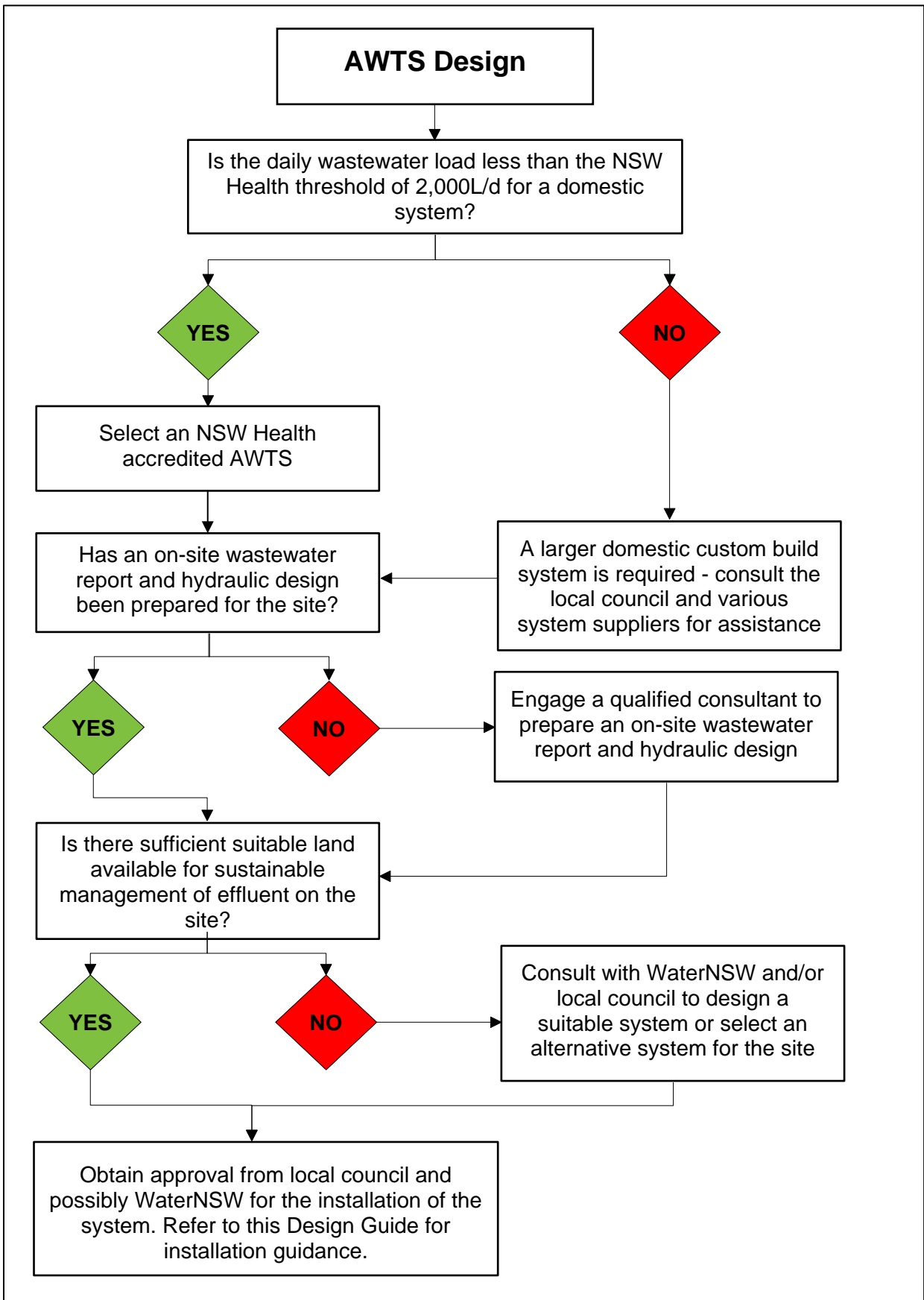

Figure 4.2 AWTS Design

## 4.1 Installation

The manufacturer or their agent usually installs AWTS tanks in compliance with the manufacturer's recommendations, [AS/NZS 3500.2:2021 Plumbing and drainage Sanitary plumbing and drainage](#) and Council requirements. System installers and Council inspectors can use Checklist 4.1 to ensure the AWTS has been installed correctly. The following extra steps provide details that are not included in the checklist.

### **Step 1**                    **Transporting tanks**

All proprietary tanks should be manufactured and transported to the installation site as one complete unit to preserve their structural integrity. Tank manufacturers can recommend suitable transport methods based on the tank type. Tanks should be kept upright and not laid on their side.

### **Step 2**                    **Lifting and moving tanks**

All tanks should only be lifted or moved using the lifting points shown on the outside of the tank. Tanks should not be lifted by the rim or lid/inspection holes. Do not use a forklift unless the lift arms reach completely underneath the tank to support the base.

### **Step 3**                    **Excavating and preparing the hole for tanks**

The depth of the hole for the tank depends on the fall of the pipe to the tank and the distance from the installed tank to the wastewater source. The tank should be installed so that the lid remains at least 100 millimetres (mm) above final ground level to avoid stormwater entering the tank. The hole must be clear of roots and foreign matter. The excavation must allow space to fix tank anchors as per the manufacturer's recommendations, if needed. The base of the hole must have a clean bed of compacted sand at least 50 mm deep. The sand surface must be flat and level.

### **Step 4**                    **Installing tanks**

Tanks should be carefully lowered into the hole and not dropped. Use lifting equipment to adjust the position of the tanks. The tank inlet should be in line with the inlet pipes.

### **Step 5**                    **Connecting pipes and fittings**

Connect the tank inlet to the inlet pipe using a 100 mm rubber sleeve and secure it according to plumbing practices detailed in [AS/NZS 3500.2:2021 Plumbing and drainage Sanitary plumbing and drainage](#) and the manufacturer's recommendations. Methods to secure pipe work into inlets and outlets vary with the different tanks, which may include concrete, fibreglass or polyethylene.

### **Step 6**                    **Sealing pipes and lids**

Seal tank lids and inlet and outlet connections with an appropriate durable and flexible sealant to stop stormwater entering the tank.

### **Step 7**                    **Drainage**

If stormwater or groundwater cannot adequately drain away from the tank hole, the tank could move resulting in failed or broken pipes and connections, and/or the tank could lift completely out of the ground. Infiltrated stormwater and/or groundwater should be drained from around the tank using agricultural (Ag) pipe (Figure 4.3) and a free draining backfill. This may not be possible if there is not enough fall for the water to leave the pipes. In this case the tank may need to be anchored (Step 8).

Sloping sites and sites with high surface water flows may need stormwater diversion devices to prevent ponding and pooling around the top of the installed tank. A surface drainage berm to divert surface water run-off from pooling around the tank can be built using mounded soil before vegetating (see Figure 4.4).

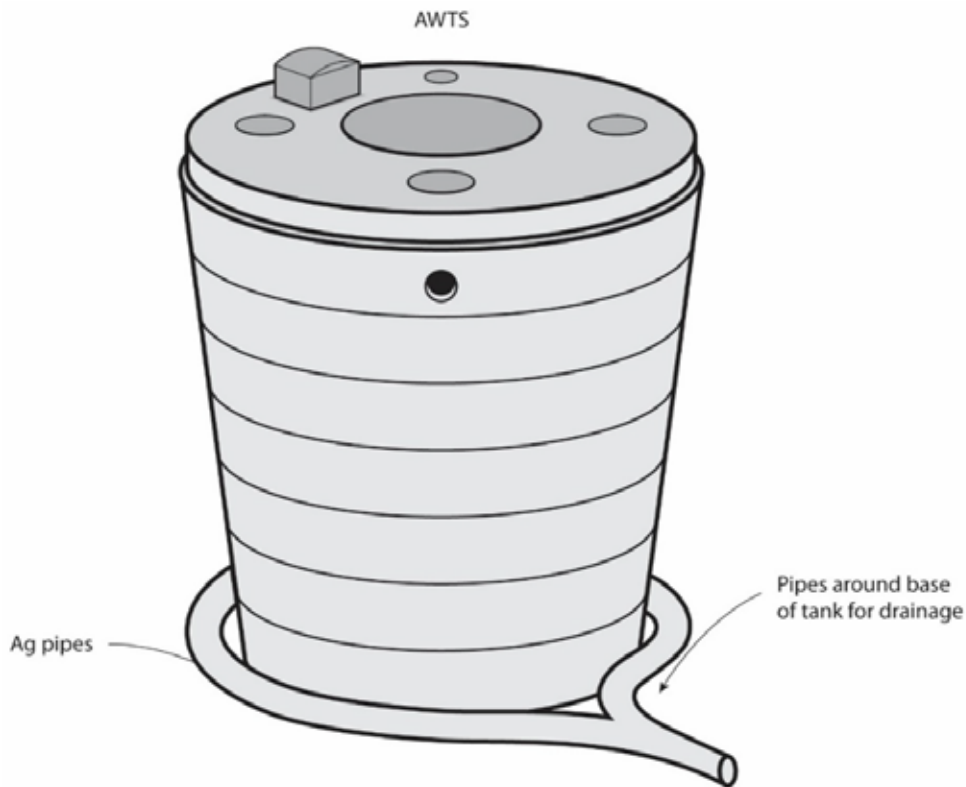

Figure 4.3 Ag pipes around base of tank for drainage

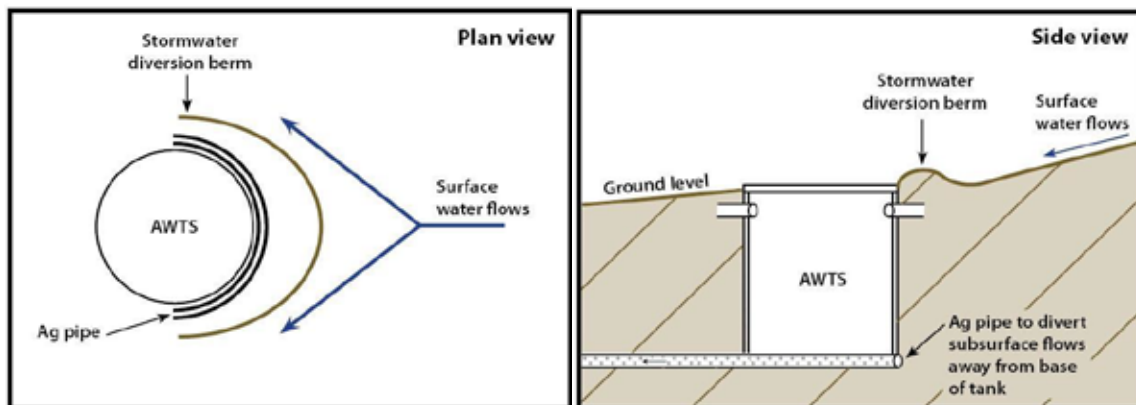

Figure 4.4 Tank stormwater drainage design

### Step 8 Attaching ground anchors (if needed)

If groundwater levels are high and/or drainage cannot be installed, ground anchors may be needed (Figure 4.5). The size and installation of ground anchors must comply with '[AS/NZS 1546.1:2008 On-site domestic wastewater treatment units – Septic tanks, section 3.2.2 Anchorage](#)'.

Loops connecting the anchors to the tank must be fitted when the tank is installed. Each side of the tank must be anchored using a piece of filled pipe attached to the tank by durable ties made from stainless steel cable. These ties are fitted to the anchor points on the tank and have a loop in the other end at excavation base level. Backfilling covers the anchors securing the tank in the ground. To prepare ground anchors you must:

- fill the ground anchors (100 millimetres uPVC sewer pipe) with sand and cap the ends. Attach at least two anchors to a tank, parallel to each other, on opposite sides of the tank.

Use more anchors if the soil is prone to saturation. The anchors should be at least as long as the diameter of the tank

- secure the free end loops of cable around the ends of each ground anchor, with two cables to each anchor
- fit a stainless steel shackle in each cable through pre-drilled holes in vertical ribs of each tank and secure
- hang all ground anchors level beside the tank approximately 150 millimetres from the bottom of the excavation, with cables fully secured and all fastenings securely tightened. Sand filled anchors help tighten the cables and ensure maximum effect. Do not run cables through the anchor pipes as they will cut when under loads.

Alternatively, a **hydrostatic flange and anchor collar** may be fitted. An 'L' shaped anchor collar section at least 65 millimetres wide and 6 millimetres thick should be constructed and fixed to the outside circumference of the tank with durable material protected from corrosion. The collar can be continuous around the circumference or in sections at least 600 millimetres long and fixed on opposite sides of the tank. For a vertical cylindrical tank the flange is fixed less than 300 millimetres from the base. For a horizontal cylindrical tank the flange is situated along the line of the greatest horizontal perimeter.

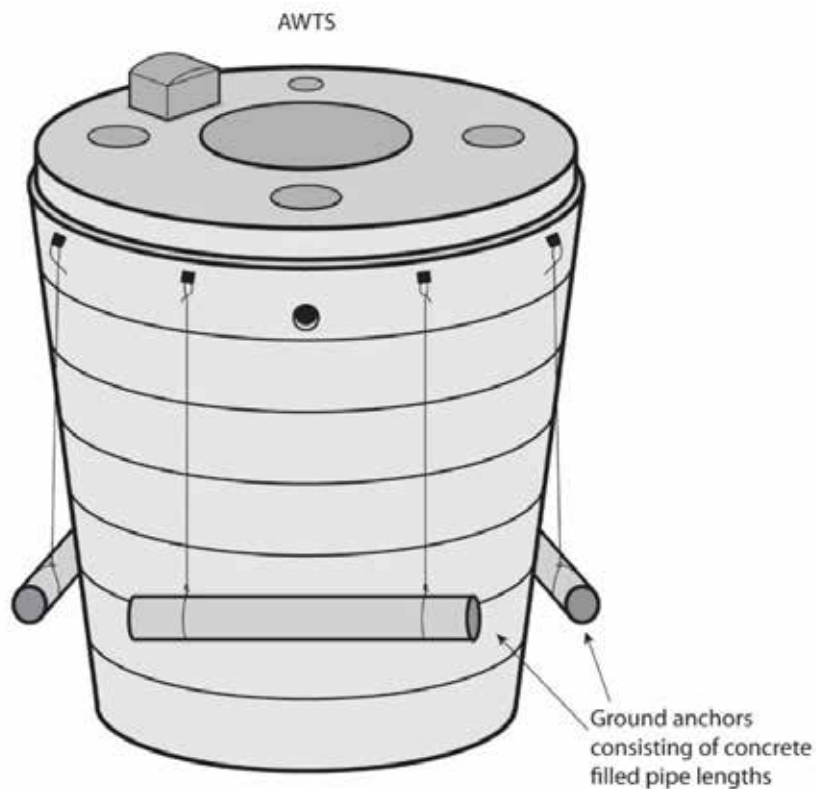

Figure 4.5 Ground anchors

### **Step 9 Venting and air supply**

AWTSs need an air supply for treatment processes. The volume of air delivered to the aeration chamber directly relates to the amount of organic matter the treatment system can remove. The air that enters the treatment system must be able to exit to complete the aeration cycle.

Substantial airflow is needed for proper aeration. The compressor and blower are positive pressure air supplies. The air supply into the treatment unit is protected by removing debris from the air with a filter, which must be installed in the air blower.

Where a blower or compressor is used for the air supply the correct diameter pipe must be used, and the number of fittings that change direction must be minimised to avoid excess friction loss in the air supply pipes. A blower needs a larger diameter pipe because of the volume of air being moved through the piping. The depth of the air discharge point will depend on the system design and can vary from one manufacturer to another. The compressor/air blower must be located on a stable foundation to prevent movement. It should also be located above the relevant council's flood planning level (FPL), and not in an area on the tank subjected to flooding.

### **Step 10 Sludge return lines**

Solids that settle in the clarifier are known as sludge. A sludge return line directs the sludge from the clarifier back into the primary and/or aeration chamber for further treatment. The sludge return pump is located at critical points where sludge settles, usually specified by the manufacturer of a proprietary system. The sludge return lines must be directed to either the aeration chamber or the septic (anoxic zone) as recommended by the system designer. Sludge return outlets should be located in or above the inlet junction of these zones, not directly into the tank, as the discharge into a scum layer of a septic zone can break down the scum layer and cause odours (see Figure 4.1). The sludge return pump must be electrically wired to the system control panel for suitable operation.

### **Step 11 Control panel**

The control panel must be watertight with all connections sealed to stop moisture or sewer gases from entering. The control panel must be easily accessible and located where audible or visual alarms can be seen and heard by the owner/occupier of the premises.

### **Step 12 Backfill**

Do not start backfilling until connections and anchoring are all complete. Some regulatory authorities require an inspection before backfilling.

### **Step 13 Vegetation**

The area around the tanks should be suitably vegetated with non-invasive plant species. Some plants can penetrate even a sealed tank and pipe work. Planting suitable species around a tank, particularly on sloping sites, is important to minimise soil erosion from the excavated area around the tanks.

Checklist 4.1 outlines a comprehensive range of inspection items for new AWTS tank installations. Councils and installers can use the checklist as part of their installation report. Installation checklists for effluent management systems are included in Sections 10 - Absorption trenches and beds, 11 - Evapotranspiration absorption beds, 12 - Surface irrigation and 13 - Subsurface irrigation.

### **Step 14 Manufacturer's instructions**

Carefully follow manufacturer's instructions for the specific type of AWTS being installed.

The system installer or Council inspector can use Checklist 4.1 when installing and inspecting the installation of an AWTS.

<b>Checklist 4.1 AWTS tank installation inspection (for system installers and Council inspectors)</b>		
Owners name:		
Address:		
Installation date:		
Tank coordinates:		
Tank description:		
<b>Type of AWTS</b>		
Manufacturer:		Model #:
Material: <input type="checkbox"/> Plastic/poly <input type="checkbox"/> Concrete <input type="checkbox"/> Fibreglass <input type="checkbox"/> Other		
Manufacturer's load bearing rating:		
Multiple tanks <input type="checkbox"/> Yes <input type="checkbox"/> No		
<b>Specified or calculated tank capacity of each tank</b>		
(1)	L	(2)                      L
Total tank capacity:		L
<b>Tank dimensions and capacities (as provided on manufacturer's design specification sheet)</b>		
	Tank (1)	Tank (2)
Exterior dimensions (diameter & height)	mm	mm
Interior dimensions (base to invert of outlet)	mm	mm
Exterior height of inlet invert	mm	mm
Exterior height of outlet invert	mm	mm
Effective depth	mm	mm
<b>Capacities of each compartment</b>		
Anaerobic (Septic):	L	Aeration:                      L
Clarifier (sludge settling):	L	Pump well (chlorine contact):                      L
Other (describe):		
<b>Excavation / setting tank</b>		
Location of tanks (describe):		
Nature of installation: <input type="checkbox"/> Free Standing <input type="checkbox"/> Buried		
Verify required inlet / outlet elevations <input type="checkbox"/> Yes <input type="checkbox"/> No		
Groundwater present in excavation <input type="checkbox"/> Yes <input type="checkbox"/> No		
Dewatering performed <input type="checkbox"/> Yes <input type="checkbox"/> No		
<b>Bottom of excavation</b>		
Level <input type="checkbox"/> Yes <input type="checkbox"/> No		
Free of rock and debris <input type="checkbox"/> Yes <input type="checkbox"/> No		

Checklist 4.1 continued			
Bedding material			
Description:			
Depth:			cm
Free of large rocks and debris	<input type="checkbox"/>	Yes	<input type="checkbox"/>
Levelled and compacted	<input type="checkbox"/>	Yes	<input type="checkbox"/>
Structural integrity of tank verified			
Tank installed level	<input type="checkbox"/>	Yes	<input type="checkbox"/>
Tank oriented correctly	<input type="checkbox"/>	Yes	<input type="checkbox"/>
Flotation prevention (for buried tanks only)			
Buoyancy calculation provided on design	<input type="checkbox"/>	Yes	<input type="checkbox"/>
Tank collar installed	<input type="checkbox"/>	Yes	<input type="checkbox"/>
Anchor weight installed	<input type="checkbox"/>	Yes	<input type="checkbox"/>
Other (describe):			
Backfill			
Backfill material:			
Free of debris and large rocks	<input type="checkbox"/>	Yes	<input type="checkbox"/>
Compacted	<input type="checkbox"/>	Yes	<input type="checkbox"/>
Piping			
Piping in appropriate sequence (inlet/outlet)		<input type="checkbox"/>	Yes
Inlet:	mm	Outlet / supply line:	mm
Pipe specifications (nominal diameter and material)			
Return line:	mm	Electrical conduit:	mm
Joints in excavated area	<input type="checkbox"/>	Yes	<input type="checkbox"/>
Pipe sealing			
Pipes sealed (including electrical conduit)		<input type="checkbox"/>	Yes
Type of sealant	Inlet:		
	Outlet / supply line:		
	Return line:		
	Electrical conduit:		
Recirculation device		<input type="checkbox"/>	Yes
Type of device:			
Tank lids			
Venting	<input type="checkbox"/>	Yes	<input type="checkbox"/>
Tank vent (describe):			
Tank water tightness testing	<input type="checkbox"/>	Yes	<input type="checkbox"/>
Manufacturer testing	<input type="checkbox"/>	Yes	<input type="checkbox"/>

<b>Checklist 4.1 continued</b>		
Pumps operational	<input type="checkbox"/> Yes	<input type="checkbox"/> No
Pump timing	<input type="checkbox"/> Yes	<input type="checkbox"/> No
Alarm to indicate no irrigation / high water	<input type="checkbox"/> Yes	<input type="checkbox"/> No
Service contract in place	<input type="checkbox"/> Yes	<input type="checkbox"/> No
<p><b>Comments, actions or repairs needed:</b>            (Where a response in this checklist needs extra information or action, specify the action plan and/or the process to fix the problem, or specify an alternative that is being offered)</p>		
<p><b>Service provider:</b></p> <p><b>Title:</b></p> <p><b>Contact number:</b></p>		
<b>Name of inspector:</b>		
<b>Signature:</b>	<b>Date:</b>	

## 4.2 Testing

### Electrical components

All electrical components should be tested by an appropriately qualified technician.

### Pumps

All pumps should be clean water tested before commissioning and pressure tested to ensure the desired pressure can be achieved for the pumps' specific purpose.

### Water tightness

Seal all joints with flexible sealant according to the manufacturer's instructions so they are watertight. Secure the AWTS lid and inspection openings to provide a watertight seal.

### Pre-commissioning checks

- Check pressure of air blower
- Check all air diffusers are working and adjust air valves to appropriate settings
- Check sludge and skimmer return lines are working
- Check float switch levels and pump activation levels
- Check alarms work
- Check the operation of the irrigation pump.

## 4.3 Inspection

A Council inspector should inspect the tank and all associated pipe and drainage work before backfilling, to ensure all components are correctly positioned and installed according to the [ABCB National Construction Code \(NCC\) Series Volume Three – Plumbing Code of Australia](#) (Commonwealth of Australia, and the States and Territories of Australia 2022, published by the Australian Building Codes Board). Council should make a final installation inspection to ensure compliance with all consent conditions, before issuing an approval to operate the system. Council inspectors can use Checklist 4.1 to ensure the system has been installed correctly.

## 4.4 Operation

The plant should be inspected quarterly by the designated service provider. This detailed maintenance inspection should include:

- checking that pumps, motors and blower assemblies are operating correctly. If the system includes a standby pump, motor or blower, it should be alternated with the operating piece from time to time to ensure that the work hours on both are approximately equal
- checking that the Dissolved Oxygen (DO) in the aeration chamber, when the aeration is operating, is greater than 2mg/L. This is critical to ensure effective treatment. Generally, the level of aeration in the aeration chamber should not exceed 4mg/L.
- checking the sludge return lines and skimmers are working properly, and excess sludge and scum does not accumulate in the clarification chamber. It is important to maintain an appropriate balance of air supply for aeration and operation of air-lift sludge return lines and skimmers.
- a suitably qualified person servicing the pump and control system according to any schedule set by the manufacturer. Pump(s) should be serviced at least once a year
- checking the sludge depth – accumulated solids in the primary tank and possibly the aeration chamber may need to be pumped out by an approved contractor

- inspecting the control system and ensuring that it is set to deliver appropriate volumes of effluent to specific irrigation fields according to the design hydraulics.

Council inspectors can use Checklist 4.2 to ensure the system is operating correctly.

### Desludging

Sludge accumulation in septic tank chambers should be inspected regularly as part of the maintenance schedule and the sludge depth measured with an appropriate device (Figure 4.6). Guidance on the frequency of sludge removal is provided in [AS/NZS 1547:2012](#). Sludge removal should be undertaken by an experienced and licensed contractor.



**Figure 4.6** Testing sludge depth using a 'Sludge Depth Indicator'

When sludge is removed from a septic tank chamber, approximately 10% of the original contents should be retained in the tank to help regenerate an appropriate bacterial population for ongoing treatment. Once pumped out, the septic tank chamber should be refilled with water to its normal operating level to ensure that the tank is not subject to undue upward pressure from high groundwater. If the groundwater level in the vicinity of the tank is high, the tank should be pumped and simultaneously partially refilled with clean water. Once pumped out, replace all inspection openings and seal the tank lid with flexible sealant.

### General maintenance

The system owner needs to complete a number of general maintenance and operational tasks, including:

- addressing maintenance issues identified by the service provider
- engaging a contractor to de-sludge the system when it is recommended by the service provider or council

- ensuring all products used in the household are safe for an AWTS (bleaches, many household cleaning products, and certain medications are not safe as they can adversely affect the biological activity)
- managing the vegetation around the tank and effluent management areas (including mowing and trimming back bushes for maximum exposure)
- ensuring a continuous power supply is provided to the system – power to the system should not be turned off when the house is unoccupied
- ensuring that the service provider is contacted as soon as practicable if an alarm activates.

Checklist 4.2 outlines items that should be checked at a three-monthly maintenance inspection for an operational AWTS. Qualified service providers and council inspectors can use this checklist for compliance inspections of an AWTS. The effluent management section of the checklist can be used for the various methods referred to in Sections 12 and 13.

#### 4.5 Common technical issues

A number of common technical problems with AWTS installations have been observed by plumbers, property owners and regulatory authorities. These include:

- not installed as per the approved design and specification
- tanks are not secured into the ground, which causes them to pop out or float and break/crack the pipes
- intermittent or low wastewater loads are resulting in a lower level of treatment
- the sludge return line was not installed or not installed correctly
- the balance of air delivered to the air diffusers and any air-lift sludge return or skimmer is incorrectly set
- aeration is not maintained at a sufficiently high level ( $DO > 2\text{mg/L}$ ), or is too high ( $DO > 4\text{mg/L}$ ) which can cause foaming
- the effluent management area is too small
- pumps have burned out and the system has failed due to disruption to the power supply
- the pump size is too small for the demands of the effluent irrigation system, resulting in overloading, pump burn out or uneven or incomplete coverage of the irrigation area
- a subsurface irrigation area flushing or return line was not installed
- stormwater in the tank because the location is too low and/or there is no runoff diversion (Figures 4.7 and 4.8)
- no valid service agreement with an appropriately qualified service provider for regular inspections.



Figure 4.7



Figure 4.8

Both figures – Low installation locations, no stormwater diversion berm / drain and inadequate sealing of lid to tank leading to stormwater inflows



Checklist 4.2 continued					
Colour of Effluent (tick one only)					
<input type="checkbox"/> Dark brown (good)	<input type="checkbox"/> Light brown (insufficient aeration times)	<input type="checkbox"/> Dark grey (insufficient oxygen delivery)			
Suspended growth system:		<input type="checkbox"/> Yes (conduct settleability test)	<input type="checkbox"/> No		
Settleability test					
<input type="checkbox"/> Clear (good)	<input type="checkbox"/> Bulky (excess sludge accumulation)	<input type="checkbox"/> Turbid (short residence time and carry over)			
Trickling filter					
Recirculation pump operational	<input type="checkbox"/> Yes	<input type="checkbox"/> No	Distribution plate biofilm good	<input type="checkbox"/> Yes	<input type="checkbox"/> No
Rotating arm / sprayer operational	<input type="checkbox"/> Yes	<input type="checkbox"/> No	Timer working correctly	<input type="checkbox"/> Yes	<input type="checkbox"/> No
Clarification zone					
Sludge return operating	<input type="checkbox"/> Yes	<input type="checkbox"/> No	Clarity	<input type="checkbox"/> Clear	<input type="checkbox"/> Cloudy
Scum return operating	<input type="checkbox"/> Yes	<input type="checkbox"/> No	Sludge depth	<input type="checkbox"/> High	<input type="checkbox"/> Med
Disinfection					
<b>Chlorine</b>		<input type="checkbox"/> Yes	<input type="checkbox"/> No		
Turbidity:			NTU		
Chlorinator intact & operating		<input type="checkbox"/> Yes	<input type="checkbox"/> No	<input type="checkbox"/> N/A	
No. tablets consumed:		No. tablets replaced:			
Free chlorine:			mg/L		
<b>Ultraviolet (UV)</b>		<input type="checkbox"/> Yes	<input type="checkbox"/> No		
Turbidity:			NTU		
Lamp cleaned		<input type="checkbox"/> Yes	<input type="checkbox"/> No	<input type="checkbox"/> N/A	
Lamp replaced		<input type="checkbox"/> Yes	<input type="checkbox"/> No	<input type="checkbox"/> N/A	
Irrigation Chamber					
Irrigation pump operational	<input type="checkbox"/> Yes	<input type="checkbox"/> No	Float switches operational	<input type="checkbox"/> Yes	<input type="checkbox"/> No
Presence of sludge	<input type="checkbox"/> Yes	<input type="checkbox"/> No	Alarm operational	<input type="checkbox"/> Yes	<input type="checkbox"/> No
Electrical components					
Alarms tested:					
Water		<input type="checkbox"/> Yes	<input type="checkbox"/> No		
Air		<input type="checkbox"/> Yes	<input type="checkbox"/> No		
General condition:			<input type="checkbox"/> Good	<input type="checkbox"/> Fair	<input type="checkbox"/> Poor
Effluent Management Area					
Evidence of physical damage		<input type="checkbox"/> Yes	<input type="checkbox"/> No		
Comments:					

Checklist 4.2 continued		
Presence of surface ponding / runoff from the effluent irrigation area:		<input type="checkbox"/> Yes <input type="checkbox"/> No
Excess weed growth in the area:		<input type="checkbox"/> Yes <input type="checkbox"/> No
Effluent running into dam, stormwater drain or watercourse:		<input type="checkbox"/> Yes <input type="checkbox"/> No
Subsurface Irrigation	Trench / Bed / Mound	
Operating pressure: <input type="checkbox"/> Good <input type="checkbox"/> Poor	Check surface ponding / toe leaching: <input type="checkbox"/> Yes <input type="checkbox"/> No <input type="checkbox"/> N/A	
Lines back flushed: <input type="checkbox"/> Yes <input type="checkbox"/> No	Comments:	
Filter checked and cleaned: <input type="checkbox"/> Yes <input type="checkbox"/> No <input type="checkbox"/> N/A		
Sprinklers spraying in high risk area: <input type="checkbox"/> Yes <input type="checkbox"/> No	Auto sequencing valves working: <input type="checkbox"/> Yes <input type="checkbox"/> No <input type="checkbox"/> N/A	Manual valves working: <input type="checkbox"/> Yes <input type="checkbox"/> No <input type="checkbox"/> N/A
Sprinklers moved / Manual valves switched to a different effluent irrigation / trench / mound area:		<input type="checkbox"/> Yes <input type="checkbox"/> No
<p><b>Comments, action or repairs needed:</b> (Where a response in this checklist needs extra information or action, specify the action plan and/or the process to fix the problem, or specify an alternative that is being offered)</p>		
<p><b>Service provider:</b></p> <p><b>Title:</b></p> <p><b>Contact number:</b></p>		
<b>Name of inspector:</b>		
<b>Signature:</b>		<b>Date:</b>

## 4.6 Case study

A builder engaged a contractor to supply and install an AWTS for a new dwelling in the Sydney drinking water catchment. The builder also obtained all approvals needed by council and installed the system before handing the new home over to the owner to occupy. Upon inspection council officers saw that the system had not been installed according to the approval. The owner did not have a copy of the approval and did not know the system was not ready to use.

### Problem

The tanks were positioned in the correct location on-site, but the lids were not sealed to prevent stormwater entering and the lid was level with the ground surface on the upslope side of the tank. A black poly hose was coiled over the top of the tank with two butterfly sprinklers left in the pump box on the top of the tank (Figure 4.9). The approved plans for the system indicated that there would be 400 square metres of surface spray irrigation installed according to buffer distances from the dwelling and a nearby intermittent drainage line.



**Figure 4.9** New AWTS with irrigation hose coiled on top, no sprinklers and potential for stormwater inundation

### Solution

- Install the AWTS and irrigation system as required by the council approval (the installer of the wastewater and effluent management systems must be provided with the relevant conditions of consent)
- install a surface water diversion berm and/or drain around the top of the tank to divert all upslope surface water runoff away from the tank
- seal around the lid of the tank to ensure stormwater water cannot enter the system
- system installers should liaise with builders and property owners about outstanding work needed for the system to comply with council approvals.

## 5 Biological Filter System

A biological filter system (BFS; Figure 5.1) relies on microorganisms, worms and beetles to break up the organic material in wastewater. They convert the organic material into humus and maintain drainage and air porosity.

A BFS generally consists of several layers of organisms on a finely structured humus, coco-peat and geotextile fabric. Aerobic processes occur in the system that produce very little or no odour. The mechanical components generally consist of a single-phase industrial strength pump and a small air pump.

The small air pump does not supply air to the bed, but rather is required to maintain 2mg/L of Dissolved Oxygen in the stored treated effluent in the sump. Gravity outlet models do not require an air pump as they do not store treated effluent in the sump.

Effluent is commonly treated to secondary standard without disinfection in models that have biolytic type beds. Biolytic type beds are designed to produce secondary effluent at start-up and included peat or coconut fibre or coir made from the husk of coconut.

These systems generally do not include disinfection, so the effluent can only be irrigated via subsoil irrigation (300 millimetres depth minimum) or absorption systems (a NSW Health requirement). These systems require some maintenance that varies with the different system types.

This Section can also be used when considering wet composting systems (dry composting systems are discussed in Section 6 of this Manual).

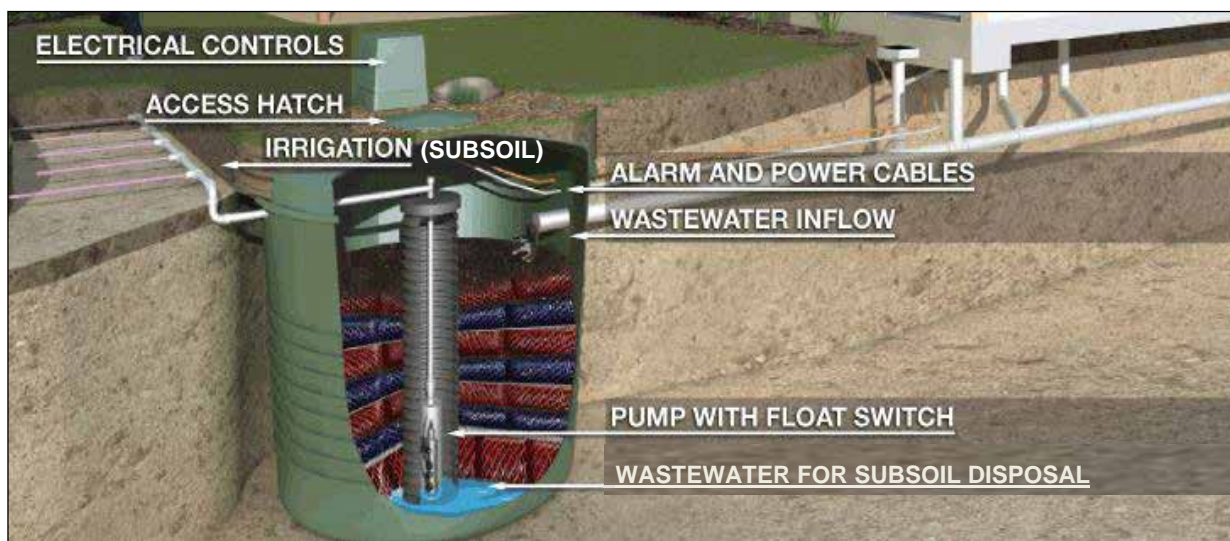

Figure 5.1 A Biological Filter System (after Biolytix, 2009)

## 5.1 Design

### System selection

Any domestic BFS installed in NSW must be accredited by NSW Health. See the NSW Health website: [www.health.nsw.gov.au/environment/domesticwastewater](http://www.health.nsw.gov.au/environment/domesticwastewater).

A regulatory authority cannot approve the installation of a non-accredited system.

It is important to choose a system that is suitable for the proposed use as all systems have features that can be either beneficial or detrimental if installed on certain sites. Things to consider when choosing a system include:

- daily wastewater load, which influences the system size
- system location – distance from the house, gravity drainage, distance from other structures
- distance from the effluent management area – influences pump size and where to locate irrigation mains.

### Design flow chart

When choosing a BFS carefully consider daily wastewater loads and site and soil constraints to ensure sustainable effluent application with a neutral or beneficial effect on water quality. Figure 5.2 shows the minimum steps involved in BFS design.

## 5.2 Installation

The installation of all tanks must comply with the manufacturer's recommendations, [AS/NZS 3500.2:2021 Plumbing and drainage Sanitary plumbing and drainage](#) and Council requirements. System installers and Council inspectors can use Checklist 5.1 to ensure the BFS is installed correctly. The following additional steps provide details not included in the checklist.

### **Step 1**                    ***Transporting tanks***

All proprietary tanks should be manufactured and transported to the installation site as one complete unit to preserve their structural integrity. Tank manufacturers can recommend suitable transport methods based on the tank type. Tanks should be kept upright and not laid on their side.

### **Step 2**                    ***Lifting and moving tanks***

All tanks should only be lifted or moved using the lifting points shown on the outside of the tank. Tanks should not be lifted by the rim or lid/inspection holes. Do not use a forklift unless the lift arms reach completely underneath the tank to support the base.

### **Step 3**                    ***Excavating and preparing the hole for tanks***

The depth of the hole for the tank depends on the fall of the pipe to the tank and the distance from the installed tank to the wastewater source. The tank should be installed so that the lid remains at least 100 millimetres above final ground level to prevent stormwater entering the tank. The hole must be clear of roots and foreign matter. The excavation must allow space to fix tank anchors as per the manufacturer's recommendations, if needed. The base of the hole must have a clean bed of compacted sand at least 50 millimetres deep. The sand surface must be flat and level.

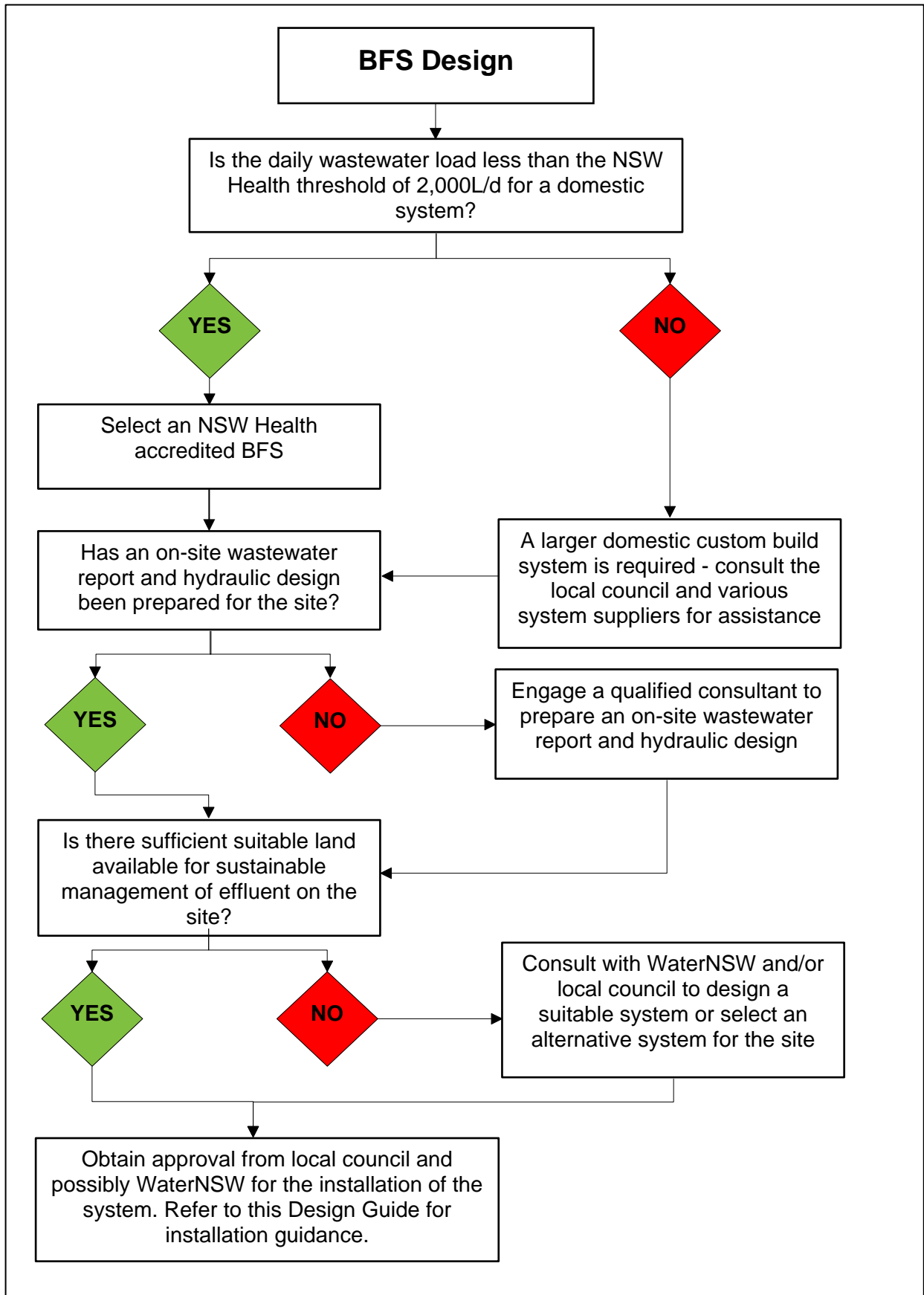

Figure 5.2 Biological filter system design

#### **Step 4**            **Installing tanks**

Tanks should be carefully lowered into the hole and not dropped. Use lifting equipment to adjust the position of the tanks. The tank inlet should be in line with the inlet pipes.

#### **Step 5**            **Connecting pipes and fittings**

Connect the tank inlet to the inlet pipe using a 100 millimetre rubber sleeve and secure it according to plumbing practices detailed in [AS/NZS 3500.2:2021 Plumbing and drainage Sanitary plumbing and drainage](#) and the manufacturer's recommendations. Methods to secure pipe work into inlets and outlets vary with the different tanks, which may include concrete, fibreglass or polyethylene.

#### **Step 6**            **Sealing pipes and lids**

Seal tank lids and inlet and outlet connections with an appropriate durable and flexible sealant.

#### **Step 7**            **Drainage**

If stormwater or groundwater cannot adequately drain away from the tank hole, the tank could move resulting in failed or broken pipes and connections and/or the tank lifting completely out of the ground. Infiltrated stormwater and/or groundwater should be drained from around the tank using agricultural (Ag) pipe (Figure 5.3) and a free draining backfill. If this is not possible because there is not enough fall for the water to exit the pipes, the tank may need to be anchored (Step 8).

Sloping sites and sites with high surface water flows may need stormwater diversion devices to prevent ponding and pooling around the top of the installed tank. A surface drainage berm to divert surface water run of from pooling around the tank can be constructed using mounded soil before vegetating (see Figure 5.4).

It is also important to ensure that the tank lid is adequately sealed and protrudes at least 100 millimetres from final ground level to prevent stormwater inundation and flooding of the tank.

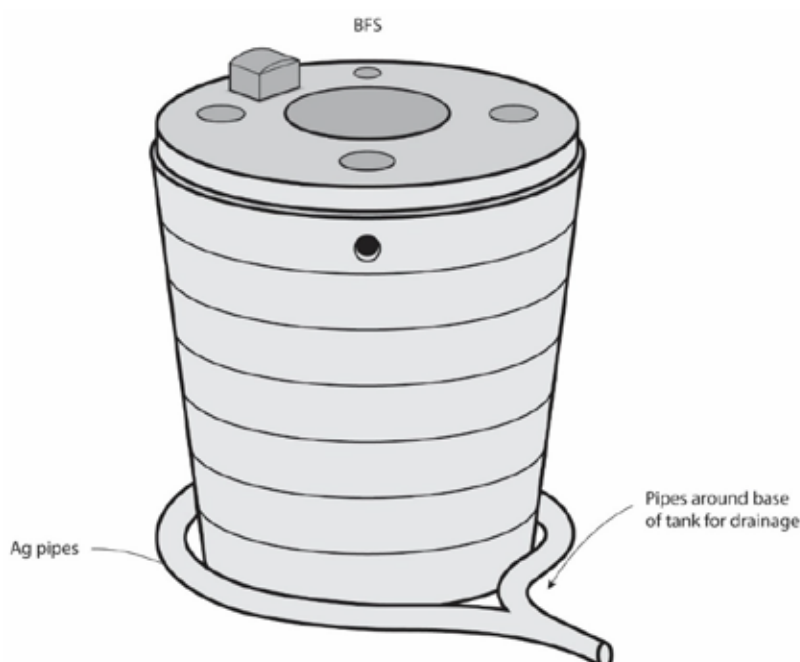

**Figure 5.3**            **Ag pipes around base of tank for drainage**

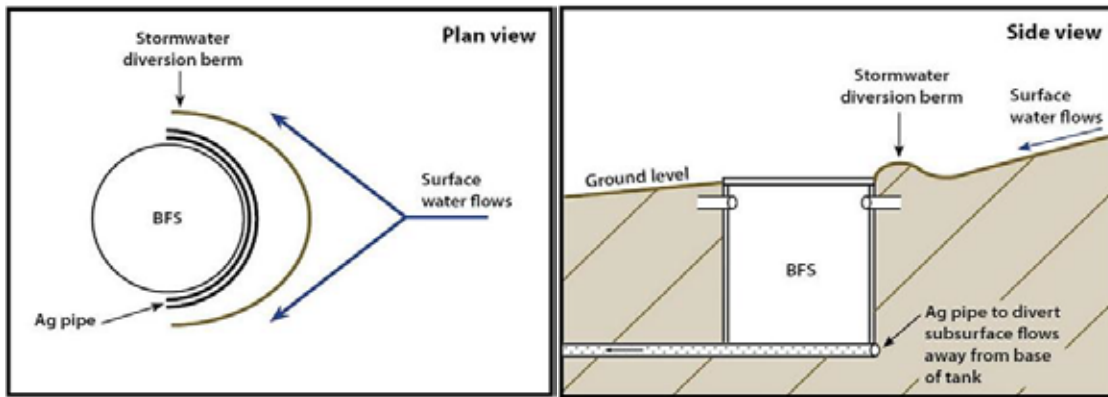

Figure 5.4 Tank stormwater drainage design

### Step 8 Attaching ground anchors

Where tanks are made from polyethylene or fibreglass, there is high groundwater on the site, or drainage cannot be installed, ground anchors will need to be attached (Figure 5.5). If they are needed, the size and installation of ground anchors must comply with [AS/NZS 1546:1:2008 On-site domestic wastewater treatment units – Septic tanks, section 3.2.2 Anchorage](#). This is particularly important with those models which have a central pump shaft. Experience has shown that pressure exerted on the base of poly tanks results in the deformation of the floor causing the pump to be lifted up to 250mm. This results in the pump catchment being reduced. This then causes the pump to short cycle, overheating the capacitor leading to failure of the pump and the thermal protection switch.

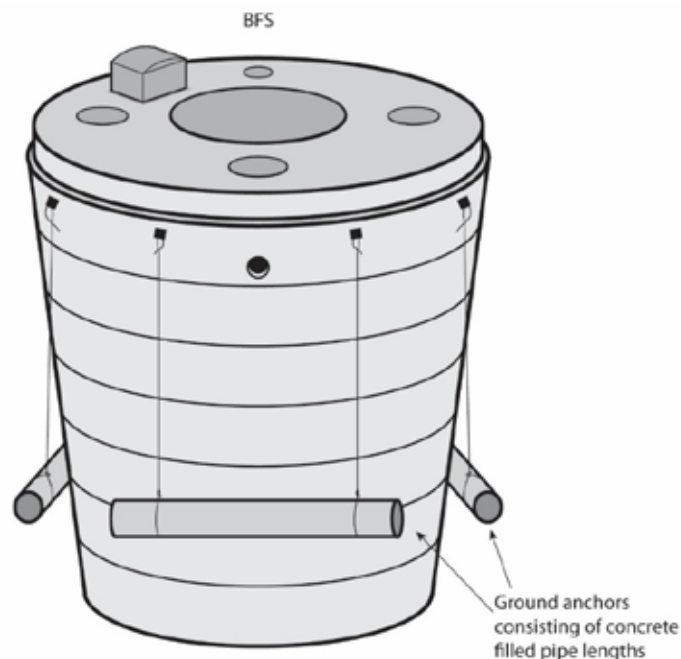

Figure 5.5 Ground anchors

When the tank is installed, loops must be fitted to connect the anchors to the tank. Each side of the tank must be anchored using a piece of filled pipe attached to the tank by durable ties made from stainless steel cable. These ties are fitted to the anchor points on the tank and have a loop in the other end at excavation base level.

Backfilling covers the anchors and secures the tank in the ground. To prepare ground anchors you must:

- fill the ground anchors (100 millimetre uPVC sewer pipe), with sand and cap the ends. Attach at least two anchors to a tank, parallel to each other, on opposite sides of the tank. Use more anchors if the soil is prone to saturation. The anchors should be at least as long as the diameter of the tank
- secure the free end loops of cable around the ends of each ground anchor, with two cables to each anchor
- fit a stainless steel shackle in each cable through pre-drilled holes in vertical ribs of each tank and secure
- hang all ground anchors level beside the tank approximately 150 millimetres from the bottom of the excavation, with cables fully secured and all fastenings securely tightened. Sand filled anchors help tighten the cables and ensure maximum effect. Never run cables through the anchor pipes as they will cut when under loads.

Alternatively, a **hydrostatic flange and anchor collar** may be fitted. An 'L' shaped anchor collar section should be constructed. It needs to be at least 65 millimetres wide and 6 millimetres thick and fixed to the outside circumference of the tank with durable material protected from corrosion. The collar may be continuous around the circumference or in at least two sections each at least 600 millimetres long and fixed on opposite sides of the tank. For a vertical cylindrical tank, fix the flange no more than 300 millimetres from the base. For a horizontal cylindrical tank, fix the flange along the line of the greatest horizontal perimeter.

### **Wet Ground Install**

The hole is to be excavated while using spear points or vortex pumps to lower the ground water level. A minimum of 2m<sup>3</sup> 20MPa concrete is required to provide ballast to a 3,000 litre poly tank with a 1.6m<sup>3</sup> bed. A 100mm thick concrete base with S72 mesh reinforcing is poured in the excavation and made level. The tank – with eight anchor points and four sand filled pipe ground anchors – is then placed on the wet concrete and levelled. The tank is then filled with water and the remaining concrete is then poured around the tank evenly, not exceeding the depth of the water ballast in the tank. This fully encapsulates the base preventing any pressure being applied to the base.

#### **Step 9 Control panel**

The control panel should be watertight with all connections sealed to prevent moisture or sewer gases from entering.

#### **Step 10 Backfill**

Do not start backfilling until connections and anchoring are all complete. Some regulatory authorities require an inspection before backfilling.

#### **Step 11 Vegetation**

The area around the tank should be suitably vegetated with non-invasive plant species. Some plants can penetrate even a sealed tank and pipe work. Planting suitable species around a tank, particularly on sloping sites, is important to minimise soil erosion from the excavated area around the tanks.

#### **Step 12 Manufacturer's instructions**

It is important to carefully follow manufacturer's instructions for the specific type of BFS being installed. The system installer or Council inspector can use Checklist 5.1 when installing and inspecting the installation of a BFS.

Checklist 5.1 outlines a comprehensive range of items to inspect for new tank installations. Councils and installers can use the checklist as part of their installation report. Installation checklists for effluent management systems are also included in Sections 10 – Absorption trenches and beds, 11 – Evapotranspiration absorption beds, 12 – Surface irrigation and 13 – Subsurface irrigation.



<b>Checklist 5.1 continued</b>			
Depth:		cm	
Free of large rocks and debris	<input type="checkbox"/> Yes	<input type="checkbox"/> No	
Levelled and compacted	<input type="checkbox"/> Yes	<input type="checkbox"/> No	
<b>Structural integrity of tank verified</b>			
Tank installed level	<input type="checkbox"/> Yes	<input type="checkbox"/> No	
Tank oriented correctly	<input type="checkbox"/> Yes	<input type="checkbox"/> No	
<b>Flotation prevention (for buried tanks only)</b>			
Buoyancy calculation provided on design	<input type="checkbox"/> Yes	<input type="checkbox"/> No	
Tank collar installed	<input type="checkbox"/> Yes	<input type="checkbox"/> No	
Anchor weight installed	<input type="checkbox"/> Yes	<input type="checkbox"/> No	
Other (describe):			
<b>Backfill</b>			
Backfill material:			
Free of debris and large rocks	<input type="checkbox"/> Yes	<input type="checkbox"/> No	
Compacted	<input type="checkbox"/> Yes	<input type="checkbox"/> No	
<b>Piping</b>			
Piping in appropriate sequence (inlet/outlet)		<input type="checkbox"/> Yes	<input type="checkbox"/> No
Inlet:	mm	Outlet / supply line:	mm
<b>Pipe specifications (nominal diameter and material)</b>			
Return line:	mm	Electrical conduit:	mm
Joints in excavated area		<input type="checkbox"/> Yes	<input type="checkbox"/> No
<b>Pipe sealing</b>			
Pipes sealed (including electrical conduit)		<input type="checkbox"/> Yes	<input type="checkbox"/> No
Type of sealant	Inlet:		
	Outlet / supply line:		
	Return line:		
	Electrical conduit:		
Recirculation device		<input type="checkbox"/> Yes	<input type="checkbox"/> No
Type of device:			
<b>Tank lids</b>			
Venting	<input type="checkbox"/> Yes	<input type="checkbox"/> No	
Tank vent (describe):			
Tank water tightness testing		<input type="checkbox"/> Yes	<input type="checkbox"/> No
Manufacturer testing		<input type="checkbox"/> Yes	<input type="checkbox"/> No
Pumps operational		<input type="checkbox"/> Yes	<input type="checkbox"/> No

<b>Checklist 5.1 continued</b>		
Pump timing	<input type="checkbox"/> Yes	<input type="checkbox"/> No
Alarm to indicate no irrigation / high water	<input type="checkbox"/> Yes	<input type="checkbox"/> No
Service contract in place	<input type="checkbox"/> Yes	<input type="checkbox"/> No
<p><b>Comments, actions or repairs needed:</b>            (Where a response in this checklist needs extra information or action, specify the action plan and/or the process to fix the problem, or specify an alternative that is being offered)</p>		
<p><b>Service provider:</b></p> <p><b>Title:</b></p> <p><b>Contact number:</b></p>		
<b>Name of inspector:</b>		
<b>Signature:</b>	<b>Date:</b>	

### 5.3 Inspection

A Council inspector should inspect the tank and all associated pipe and drainage work before backfilling to ensure all components are correctly positioned and installed according to the [ABCB National Construction Code \(NCC\) Series Volume Three – Plumbing Code of Australia](#) (Commonwealth of Australia, and the States and Territories of Australia 2022, published by the Australian Building Codes Board ). Council should make a final installation inspection to ensure compliance with all conditions of consent, before issuing an approval to operate the system.

### 5.4 Operation

A designated service provider should inspect the system at the interval specified on the certificate of accreditation by NSW Health. This detailed maintenance inspection should include:

- checking that pumps and motor assemblies are operating correctly. If the system includes a standby pump, motor or blower, it should be alternated with the operating part from time to time to ensure that the work hours on both are approximately equal
- checking that the pump and control system are serviced by a suitably qualified person according to any schedule set by individual manufacturers. The pump(s) should be serviced at least every 12 months
- checking the control system is set to deliver appropriate volumes of effluent to specific irrigation fields / disposal areas according to the design hydraulics
- checking the effluent management area.

#### General maintenance

The owner of the system also needs to complete a number of general maintenance and operational tasks, including:

- removing the composted humus after the minimum composting period has passed
- addressing any maintenance issues identified by the service provider
- ensuring all products used in the household are safe for a BFS (this excludes many household cleaning products)
- managing the vegetation around the tank and effluent management areas (this includes mowing and trimming back bushes for maximum exposure)
- ensuring the system has a continuous power supply. Power to the system must not be turned off when the house is unoccupied
- contacting the service provider as soon as practicable if any alarm triggers.

Checklist 5.2 outlines the items that should be checked at an annual maintenance inspection for an operational BFS. This checklist can be used by the qualified service provider for the system and for also council compliance inspections. The effluent management section of the checklist can be used for the various disposal methods.

In addition to the items outlined in Checklist 5.2, multi-layer composters should be chemically sump cleaned every 12 months by filling the sump to a depth of 400mm while adding 6 litres of liquid chlorine (17% strength) and agitating with air. The pump well lid and pump should be removed for cleaning while this process is carried out. Using an expanding drainage plug with an extension to attach an airline to the threaded centre of the plug, a 100-litre air blower or air compressor is connected to the line and air is pumped into the sump via the sump inspection shaft. This should continue for 20 minutes. This water can then be used to flush the sub-soil drip disposal system.

The flow rate of the pump, which is normally 30m head in systems that use drip disposal, should not be less than 20-25 litres/minute. High operating head pressures lead to short pump life and higher electrical consumption.

## 5.5 Common technical issues

A number of common problems with installing BFS have been identified by plumbers, property owners and regulatory authorities, including:

- not installed as per the approved design and specification
- tanks are not secured into the ground, which causes them to pop out or float and break/crack the pipes
- undersized pumps are used for the hydraulic gradient of the effluent irrigation system, resulting in overloading and pump burn out
- disruptions to power supply cause pump burn out and system failure
- undersized effluent management areas
- a subsoil irrigation area flushing or return line is not installed
- stormwater enters the tank because of a low location and/or runoff has not been diverted.
- blocked priming hole in pump shaft. This can cause pumps to run without prime for hours before filling the sump with sufficient effluent to open the check valve allowing the pump to prime. Sump temperatures can rise to 60 degrees Centigrade turning the sump anaerobic and blocking the textile filter
- water entering the tank via the emergency overflow drainage, filling the sump with soil and causing long run times for the pump due to reduced storage
- incorrectly set out sub soil system with feed and return flush on the same side of the field. Resulting in unbalanced flow for flushing the laterals (refer to Section 13 for design details)
- disc filters being used on the system. The effluent is filtered in the sump via a 90 micron textile filter. This causes the disc filter to block, turning anaerobic, leading to pump failure and increased slime growth in the laterals, blocking emitters
- floor deformation of the tank floor causing excessive pump on times and excessive number of starts/hr leading to capacitor or thermal switch failure.

**Checklist 5.2 Operational biological filter system inspection report for use by service providers and Council inspectors**

Owner's name:		
Address:		Council area:
Installation date:		
Tank coordinates:		Effluent Management Area coordinates:
System brand and model:		<input type="checkbox"/> Domestic <input type="checkbox"/> Commercial
Date of service:	Date of last service:	Next service due:
<b>General Comments</b>		
General condition of tank		<input type="checkbox"/> Good <input type="checkbox"/> Fair <input type="checkbox"/> Poor
Comments:		
<b>Treatment Chamber</b>		
Odour present:	<input type="checkbox"/> Yes <input type="checkbox"/> No	Filter humus depth: <input type="checkbox"/> High <input type="checkbox"/> Med <input type="checkbox"/> Low
Inlet/outlet junctions Clear:	<input type="checkbox"/> Yes <input type="checkbox"/> No	Good biological activity: <input type="checkbox"/> Yes <input type="checkbox"/> No
pH:	Dissolved oxygen: mg/L	
Chemical sump cleaning <sup>(1)</sup>		<input type="checkbox"/> Yes <input type="checkbox"/> No
<b>Colour of Effluent (select one only)</b>		
<input type="checkbox"/> Dark brown (good)	<input type="checkbox"/> Light brown (insufficient aeration times)	<input type="checkbox"/> Dark grey (insufficient oxygen delivery) <input type="checkbox"/> Turbid (short residence time and carry over)
<b>Irrigation Chamber</b>		
Irrigation pump operational	<input type="checkbox"/> Yes <input type="checkbox"/> No	Float switches operational <input type="checkbox"/> Yes <input type="checkbox"/> No
Presence of sludge	<input type="checkbox"/> Yes <input type="checkbox"/> No	Alarm operational <input type="checkbox"/> Yes <input type="checkbox"/> No
<b>Electrical components</b>		
Alarms tested:		
Water	<input type="checkbox"/> Yes <input type="checkbox"/> No	
Air	<input type="checkbox"/> Yes <input type="checkbox"/> No	
Electrical compartment in good working order	<input type="checkbox"/> Yes <input type="checkbox"/> No	
General condition	<input type="checkbox"/> Good <input type="checkbox"/> Fair <input type="checkbox"/> Poor	

Checklist 5.2 continued		
Effluent Management Area		
Evidence of physical damage:	<input type="checkbox"/> Yes <input type="checkbox"/> No	Comments:
Presence of surface ponding / runoff from the effluent irrigation area:	<input type="checkbox"/> Yes <input type="checkbox"/> No	
Excess weed growth in the area:	<input type="checkbox"/> Yes <input type="checkbox"/> No	
Effluent running into dam, stormwater drain or watercourse:	<input type="checkbox"/> Yes <input type="checkbox"/> No	
Subsoil Irrigation <sup>(2)</sup>		Trench / Bed / Mound
Operating pressure: <input type="checkbox"/> Good <input type="checkbox"/> Poor	Check surface ponding / toe leaching: <input type="checkbox"/> Yes <input type="checkbox"/> No <input type="checkbox"/> N/A	
Lines back flushed: <input type="checkbox"/> Yes <input type="checkbox"/> No	Comments:	
Filter checked and cleaned: <input type="checkbox"/> Yes <input type="checkbox"/> No <input type="checkbox"/> N/A		
Sprinklers spraying in high risk area <input type="checkbox"/> Yes <input type="checkbox"/> No	Auto sequencing valves working <input type="checkbox"/> Yes <input type="checkbox"/> No <input type="checkbox"/> N/A	Manual valves working <input type="checkbox"/> Yes <input type="checkbox"/> No <input type="checkbox"/> N/A
Sprinklers moved / Manual valves switched to a different effluent irrigation / trench / mound area:		<input type="checkbox"/> Yes <input type="checkbox"/> No
<b>Comments, action or repairs needed:</b> (Where a response in the above checklist needs extra information or action, specify the action plan and/or the process to fix the problem, or specify an alternative that is being offered)		
<b>Service provider:</b>  <b>Title:</b>  <b>Contact number:</b>		
<b>Name of inspector:</b>		
<b>Signature:</b>		<b>Date:</b>
<p><sup>(1)</sup> Sump cleaning procedure</p> <ul style="list-style-type: none"> <li>· Clean the sump every 12 months</li> <li>· Remove pump well lid and pump during the cleaning</li> <li>· Fill the sump to a depth of 400 mm and adding 6 L of liquid chlorine (17% strength)</li> <li>· Use an expanding drainage plug with an extension to attach an airline to the threaded centre of the plug</li> <li>· Connect a 100 L air blower or air compressor to the line</li> <li>· Pump the air into the sump via sump inspection shaft for 20 mins</li> <li>· The cleaning water can be used to flush the sub-soil drip disposal system.</li> </ul> <p><sup>(2)</sup> Sub-soil irrigation: NSW Health requirement; if disinfected, subsurface disposal at 100-150mm may apply.</p>		

## 5.6 Case study

A biological filter system (BFS) was installed below the relevant council's flood plain level (FPL) and appeared to be working properly for the first 12 months. The BFS used minimal electricity and allowed all wastewater to be treated on-site. A subsoil irrigation system limited the chance of surface runoff of effluent, including during flooding.

### Problem

Following a severe storm/flood the owner noticed that the tank was completely full, and the pumps did not appear to be working. He called the service provider who inspected the system and found that all of the electrical components in the system had become waterlogged and failed. The electrical components had been installed below the FPL (just on top of the tank) and had been flooded during the storm. This caused the system to short out and flood, as the irrigation pump no longer worked (Figures 5.8-5.10).



Figure 5.8 An electrical box that was flooded



Figure 5.9 A flooded system due to pump failure



Figure 5.10 A flooded system due to pump failure

### Solution

Remove the tank and all electrical control components and place them at a control point that is well above the FPL, on the side of the house. During future floods the water can rise around the tank and not interfere with the electrical work as it will be located at a safe height. This solution required the service provider to engage a licensed electrician to move the electrical components as he did not have an electrical licence.

## 6 Composting Toilets

Composting toilets (Figure 6.1) rely on the action of microorganisms in an aerobic environment. Systems are usually dry (waterless); although some wet composting systems with vermiculture (worms) are available (see Section 5 Biological Filter Systems). Dry systems may be continuous flow or batch processing. Compost and any liquid waste generated require appropriate subsurface management. Compost needs to be buried at least 150 millimetres below ground. Liquid waste needs to be treated in an absorption trench.



Figure 6.1 A composting unit used in conjunction with a composting toilet

### 6.1 Design

Any domestic composting system installed in NSW must be accredited by NSW Health, and a regulatory authority cannot approve the installation of a non-accredited system. Accredited composting systems are listed on the NSW Health website.

[www.health.nsw.gov.au/environment/domesticwastewater](http://www.health.nsw.gov.au/environment/domesticwastewater).

#### Climatic conditions

A composting toilet's performance can be significantly affected by the climatic conditions, particularly in cold climates where cold temperatures slow the composting process. In cool temperatures a larger system may be needed to allow for slower decomposition of the compost.

#### Other wastewater sources

Where composting toilets are used, design considerations must also be made for other wastewater sources in the home. Composting toilets are generally used together with a greywater treatment system to manage greywater. See Section 7 of this Manual for advice on greywater treatment systems.

If more than one toilet is needed in the dwelling and the toilets are not in adjoining rooms, two systems will be required, doubling the cost of the system.

## Access

Most composting toilets are designed to sit under the dwelling, so these systems are not suited to slab on ground homes or raised homes where the toilet is in the middle of the dwelling, as regular access to the composting unit is needed to remove the humus.

## Tank systems

Wet composting systems are more adaptable to various types of dwellings as the entire wastewater stream is generally collected into one tank that can be located away from the dwelling, unlike the dry compost toilet. These systems treat the whole wastewater load from the dwelling and do not require separate greywater management. These systems use installation techniques similar to the biological filter system (see Section 5).

## Specialised plumbing requirements

Composting toilets require specialised plumbing fixtures and non-standard toilets. The internal components of the toilet usually come as part of the whole system and normal cistern toilets cannot be used (Figure 6.2). The plumbing requirements of a composting toilet are significantly different to a standard toilet with a cistern. The composting toilet does not have a water supply for flushing and it does not have sewer drainage pipes the same as a standard toilet as all waste falls directly into the composting unit. Nevertheless, most composting toilets require a small absorption trench to deal with excess moisture.

## Ventilation

A composting unit requires a ventilation system to manage odours and help the composting process. The ventilation system generally consists of a small electric fan in the vent pipe. A power supply is usually needed for the venting system.

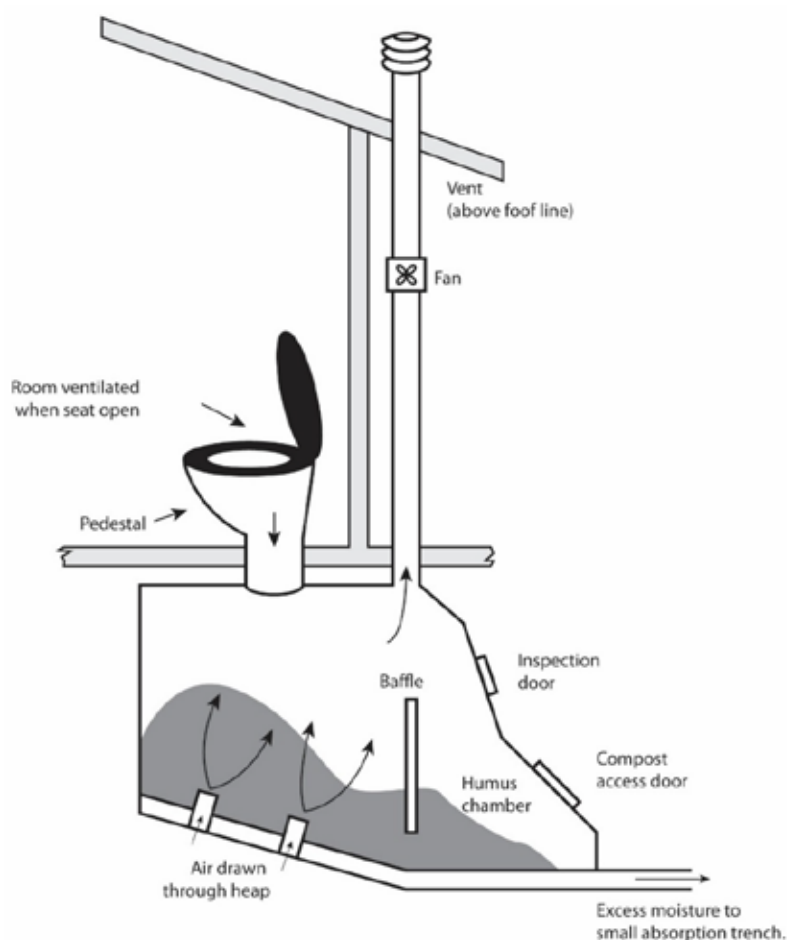

Figure 6.2 A typical section of composting toilet

## 6.2 Installation

The installation of all composting toilets must comply with the manufacturer's recommendations, [AS/NZS 3500.2:2021 Plumbing and drainage Sanitary plumbing and drainage](#) and Council requirements. System installers and Council inspectors can use Checklist 6.1 to ensure the composting toilet has been correctly installed. The following additional steps provide details not included in the checklist.

### **Step 1**                    **Transporting dry composting tank**

All proprietary composting tanks should be manufactured and transported to the installation site so that the structural integrity of the tanks is not compromised. Manufacturers of tanks can recommend suitable transport methods based on the tank type.

### **Step 2**                    **Lifting and moving composting tank**

All tanks should only be lifted or moved using the lifting points shown on the outside of the tank. Tanks should not be lifted by the rim or lid/inspection holes. Do not use a forklift unless the lift arms reach completely underneath the tank to support the base.

### **Step 3**                    **Installing composting tank**

Lifting equipment may be used to adjust the position of the tank.

### **Step 4**                    **Connection of pipes and fittings**

Connect the system according to the plumbing practices detailed in [AS/NZS 3500 Set \(Parts 0-4\):2021 Plumbing and drainage](#) and the manufacturer's recommendations. Methods used to secure pipe work into outlets vary with the different composting units, which are typically polyethylene.

### **Step 5**                    **Sealing pipes**

Seal composting tank outlet connections with an appropriate durable and flexible sealant.

### **Step 6**                    **Drainage**

During installation, it is important to ensure good drainage of stormwater from around the composting unit. If stormwater or groundwater cannot properly drain away from or around the composting tank, the tank may move causing pipes to break. Stormwater should be diverted around the tank using agricultural (Ag) pipe and a free draining soil to minimise the chance of stormwater pooling around the composting tank and causing movement.

### **Step 7**                    **Venting**

Install the venting system supplied by the manufacturer according to the manufacturer's recommendations and [AS/NZS 3500 Set \(Parts 0-4\):2021 Plumbing and drainage](#).

### **Step 8**                    **Internal fixtures**

Install the internal fixtures (toilet pan and ancillary equipment) supplied by the manufacturer according to the manufacturer's recommendations and [AS/NZS 3500 Set \(Parts 0-4\):2021 Plumbing and drainage](#)

### **Step 10** **Manufacturer's instructions**

Carefully follow manufacturer's instructions for the specific type of composting toilet being installed.

The system installer or Council inspector can use Checklist 6.1 when installing and inspecting the installation of a composting toilet. This includes the construction of an excess liquid absorption trench where needed. Installation checklists for effluent management systems are also included in Sections 10 – Absorption trenches and beds, 11 – Evapotranspiration absorption beds, 12 – Surface irrigation and 13 – Subsurface irrigation.

<b>Checklist 6.1 Dry composting toilet installation inspection for installers and councils</b>			
Owners name:			
Address:			
Installation date:			
Tank coordinates:			
Tank description:			
<b>Type of composting toilet</b>			
Manufacturer:		Model #:	
Material: <input type="checkbox"/> Plastic/Poly <input type="checkbox"/> Concrete <input type="checkbox"/> Fibreglass <input type="checkbox"/> Other			
<b>Composting tank dimensions and capacity</b>			
Exterior dimensions:		mm	Effective depth: mm
Total tank capacity:			m <sup>3</sup>
<b>Setting composting tank</b>			
Location of composting tanks (describe):			
Nature of installation:		<input type="checkbox"/> Free Standing	<input type="checkbox"/> Buried
Multiple systems		<input type="checkbox"/> Yes	<input type="checkbox"/> No
<b>Bottom of excavation</b>			
Level		<input type="checkbox"/> Yes	<input type="checkbox"/> No
Free of rock and debris		<input type="checkbox"/> Yes	<input type="checkbox"/> No
<b>Bedding material</b>			
Description:			
Depth:			cm
Free of large rocks and debris		<input type="checkbox"/> Yes	<input type="checkbox"/> No
Levelled and compacted		<input type="checkbox"/> Yes	<input type="checkbox"/> No
<b>Backfill</b>			
Backfill material (describe):			
Free of debris and large rocks		<input type="checkbox"/> Yes	<input type="checkbox"/> No
Compacted		<input type="checkbox"/> Yes	<input type="checkbox"/> No
<b>Structural integrity of tank verified</b>			
Tank installed level		<input type="checkbox"/> Yes	<input type="checkbox"/> No
Tank oriented correctly		<input type="checkbox"/> Yes	<input type="checkbox"/> No
<b>Free standing above ground</b>			
Flat bed		<input type="checkbox"/> Yes	<input type="checkbox"/> No
Compacted		<input type="checkbox"/> Yes	<input type="checkbox"/> No
Verify required outlet elevations		<input type="checkbox"/> Yes	<input type="checkbox"/> No

Checklist 6.1 continued	
<b>Venting</b>	
Venting installed as per manufacturer's requirements	<input type="checkbox"/> Yes <input type="checkbox"/> No <input type="checkbox"/> N/A
<b>Pipe sealing</b>	
Excess moisture pipe to absorption trench: Type of sealant (describe or N/A):	
Electrical conduit: Type of sealant (describe or N/A):	
Other: Type of sealant (describe or N/A):	
<b>Comments or repairs needed:</b> (Where a response in this checklist needs extra information or action, specify the action plan and/or the process to fix the problem, or specify an alternative that is being offered)	
<b>Service provider:</b>  <b>Title:</b>  <b>Contact number:</b>	
<b>Name of inspector:</b>	
<b>Signature:</b>	<b>Date:</b>

### 6.3 Inspection

A Council inspector should inspect the composting tank and all associated pipe and drainage work to ensure all components are correctly positioned and installed according to the [ABCB National Construction Code \(NCC\) Series Volume Three – Plumbing Code of Australia](#) (Commonwealth of Australia, and the States and Territories of Australia 2022, published by the Australian Building Codes Board). Council should make a final installation inspection to ensure compliance with all conditions of consent before issuing an approval to operate the system.

Appropriate items to check on installation of a composting toilet are outlined in Checklist 6.2.

### 6.4 Operation

Daily operation of some composting systems requires adding a supplementary carbon source. This often means adding sawdust to the compost pile. After each use of the system a small scoop of sawdust is poured down the toilet onto the compost pile. The fresh sawdust supply should be refilled at appropriate intervals depending on the use of the system. Composting systems need to be inspected periodically, and composted humus needs to be removed and buried. The compost bins in some batch composting systems need to be rotated by replacing a full bin with an empty one. Extra worms may need to be added. Homeowners need to be aware of, and willing to meet, the maintenance needs for these systems.

### 6.5 Common technical issues

Plumbers, property owners and regulatory authorities have observed a number of common problems with composting toilet installations, including:

- not installed as per the approved design and specification
- problems due to an inappropriate load type i.e. composting systems need a sufficient amount of solid faecal matter to operate properly. When installed at locations where the load is mainly urine, for example at roadside stops, composting is less effective because the compost pile is saturated by the mainly liquid (urine) load
- failing to remove humus from the humus chamber at appropriate intervals can mean less airflow around the compost pile or clogging in the compost chamber
- odours from the compost pile due to ineffective composting or inadequate ventilation
- absorption trenches that are too small to handle excessive moisture.

Checklist 6.2 Operational inspection of a composting toilet for use by councils	
Owners name:	
Address:	
Installation date:	
Tank coordinates:	
Is an appropriate instruction notice fixed in place near the toilet to inform users of the nature and operation of the composting toilet?	<input type="checkbox"/> Yes <input type="checkbox"/> No
Is there adequate ventilation?	<input type="checkbox"/> Yes <input type="checkbox"/> No
Is the exhaust fan operational?	<input type="checkbox"/> Yes <input type="checkbox"/> No
Is there an available and appropriate supply of sawdust?	<input type="checkbox"/> Yes <input type="checkbox"/> No
Is there adequate access for the purposes of humus removal?	<input type="checkbox"/> Yes <input type="checkbox"/> No
Has the biological activity in the composting chamber produced satisfactory quality humus (i.e. dry and friable)?	<input type="checkbox"/> Yes <input type="checkbox"/> No
Has provision been made for periodic inspection of the compost chamber?	<input type="checkbox"/> Yes <input type="checkbox"/> No
Is there provision for humus removal and burial to a depth of 150mm and is it further than 40m from drainage depressions, farm dams and roadside drainage and lot scale stormwater quality improvement devices (SQIDs) and 100m from Watercourses, lakes and the full supply level for all water supply reservoirs?	<input type="checkbox"/> Yes <input type="checkbox"/> No
Is humus buried on a flood plain or in an area likely to be flooded?	<input type="checkbox"/> Yes <input type="checkbox"/> No
Is there a compost tank available and being used for rotation?	<input type="checkbox"/> Yes <input type="checkbox"/> No <input type="checkbox"/> N/A
<b>Comments or repairs needed:</b> (Where a response in this checklist needs extra information or action, specify the action plan and/or the process to fix the problem, or specify an alternative that is being offered)	
<b>Service provider:</b>	
Title:	
Contact number:	
Name of inspector:	
Signature:	Date:

## 6.6 Case study

A composting toilet was installed on a small residential block in the Blue Mountains and greywater was managed in a greywater treatment system (see Section 8), as there was very little room for on-site effluent management. The composting unit was fitted underneath the floor of the bathroom (Figure 6.3), with the composting toilet located directly above. Composted material (humus) needed to be removed every three to six months depending on accumulation rates, and the owner needed to regularly monitor the amount accumulated.



Figure 6.3 The installed composting unit, before installation of bathroom and steps



Figure 6.4 New steps blocking access to the composting unit

### Problem

The composting unit was located under the floor of the dwelling and there was very limited space between the unit and the floor level. A set of steps was constructed from floor level to ground level that largely blocked access to the composting unit (Figure 6.4). The owner could not regularly monitor the amount of composted material and the system became blocked.

### Solution

Poor design has meant a major problem with access to the unit. The installer, builder and owner should have consulted before installation to decide where other features could be installed so that access would not be restricted. The toilet and associated composting unit could have been relocated away from the steps to provide easier access to the unit. The only solution in this case was to move the steps to allow that easy access to the unit.

## 7 Greywater Treatment Systems

Greywater treatment systems (GTS) collect, store and treat greywater to a quality that allows it to be reused for toilet flushing, clothes washing, or subsurface irrigation in gardens. Installing a greywater treatment system does not eliminate the need to deal with black water from the toilet and kitchen, which must be treated separately. Often the cost of installing both greywater and black water treatment systems can be more than the cost of one treatment system that would deal with both grey and black water.

The most common treatment process involves settling of solids, flotation of lighter materials, anaerobic digestion, aeration, clarification and disinfection. Disinfection to reduce pathogenic micro-organisms is the final process. It usually involves chlorinating clarified water.

There are a number of NSW Health accredited GTS available on the market using a range of treatment technologies (Figures 7.1 and 7.2).



Figure 7.1 Example of an Ultra GTS Greywater Treatment System (left) (Wastewater Australia)



Figure 7.2 Schematic of an Ultra GTS (right) (Wastewater Australia)

All GTSs installed in the Sydney drinking water catchment need to use fixed surface or subsurface management and comply with all WaterNSW requirements for buffer distances from drainage depressions, farm dams and roadside drainage and lot scale stormwater quality improvement devices (SQIDs) (40 metres), and from watercourses, lakes and the full supply level for all water supply reservoirs (100 metres) – see Table 2.6. All greywater treatment systems in unsewered areas need to be approved by Council before installation under the *Local Government Act 1993*.

This Manual does not cover greywater diversion devices. Diversion devices are specialised plumbing fixtures that divert untreated greywater to subsurface garden irrigation. For advice on greywater diversion devices consult local council and NSW Health guidelines.

## 7.1 Design

Any domestic GTS installed in NSW must be accredited by NSW Health. A regulatory authority cannot approve the installation of a non-accredited system. Accredited greywater treatment systems are listed on the NSW Health website.

[www.health.nsw.gov.au/environment/domesticwastewater](http://www.health.nsw.gov.au/environment/domesticwastewater)

A GTS must be suitable for the desired reuse methods and daily wastewater loads. Some systems are accredited for internal reuse for toilet flushing and clothes washing, where others are only accredited for garden irrigation purposes.

GTSs use a number of treatment processes:

- bioreactors
- trickling filters
- biofilters
- media filters
- aerated treatment systems
- activated sludge systems
- membrane filters, or
- disinfection by chlorine or ultraviolet (UV).

### Daily wastewater loads

When designing a GTS for a domestic dwelling it is important to consider the input and output loads when considering potential reuse options. If treated greywater is only used for toilet flushing then less input will be needed than if it is used for toilet flushing, clothes washing and garden irrigation. Calculate a hydraulic balance for the system design before choosing which system to install. WaterNSW does not allow treated greywater to be used for landscape watering except through fixed surface or subsurface irrigation systems. Only systems with disinfection can be used for surface or subsurface irrigation. GTSs with no disinfection must use subsoil irrigation at a depth of at least 300 millimetres.

### Site assessment

Use Section 2 of this Manual to decide if the site is suitable for greywater reuse.

## 7.2 Installation

The NSW Health Certificate of Accreditation for each accredited GTS describes the requirements for installation and commissioning, maintenance and ongoing management. Installers and regulators need to refer to the requirements in the relevant Certificate of Accreditation.

Tanks must be installed in compliance with the manufacturer's recommendations, [AS/NZS 3500.2:2021 Plumbing and drainage Sanitary plumbing and drainage](#) and Council requirements. For some GTSs, it is useful to refer to the information in this Manual on installing septic tanks and aerated wastewater treatment systems.

Checklist 7.1 is a generic checklist of items to check when inspecting the installation of a GTS.



## 7.3 Testing

### Electrical components

An appropriately qualified technician should test all electrical components.

### Pumps

All pumps should be clean water tested before commissioning and pressure tested to ensure the desired pressure can be achieved for the pumps specific purpose.

### Water tightness

Seal all joints with flexible sealant according to manufacturer's instructions to ensure they are water tight. Secure the GTS lid and inspection openings to provide a watertight seal.

### Pre-commissioning checks

- Check alarms work
- Check the operation of the irrigation pump, if applicable.

## 7.4 Operation and maintenance

A service contract should be in place to ensure the GTS is serviced at the appropriate interval specified in the Certificate of Accreditation. The periodic service should check and report on all electrical, mechanical and other functioning components of the system, the operation of the collection, treatment and reuse chambers and the effective means of disinfection. A service report should be provided to the homeowner and the council. Service providers and Council inspectors can use Checklist 7.2 to inspect an operational GTS.

## 7.5 Common technical issues

Plumbers, property owners and regulatory authorities have observed a number of common problems with GTS installations including:

- not installed as per the approved design and specification
- odours in the treatment system and stored treated greywater
- blocked filters
- not enough organic material for effective bacterial treatment processes in aerated and activated sludge systems
- accumulation of settled solids that need to be pumped out or back flushed to the sewer
- colour in recycled water limiting its reuse for laundry washing and staining toilet bowls
- not enough treated effluent supplied to toilets for reuse
- possible cross connections with potable water supply
- backflow prevention.

<b>Checklist 7.2 Operational greywater treatment system inspection report for use by councils</b>					
Owner's name:					
Address:			Council area:		
Installation date:					
Tank coordinates:			Effluent management area coordinates:		
System brand and model:			<input type="checkbox"/> Domestic		<input type="checkbox"/> Commercial
Date of service:		Date of last service:		Next service due:	
<b>General Comments</b>					
General condition of tank			<input type="checkbox"/> Good	<input type="checkbox"/> Fair	<input type="checkbox"/> Poor
Comments:					
<b>Primary Chamber</b>					
Crust:		Odour:		Sludge depth:	
<input type="checkbox"/> Yes	<input type="checkbox"/> No	<input type="checkbox"/> Yes	<input type="checkbox"/> No	<input type="checkbox"/> High	<input type="checkbox"/> Med <input type="checkbox"/> Low
Desludge needed:		<input type="checkbox"/> Yes <input type="checkbox"/> No	Inlet/outlet junctions clear:		
			<input type="checkbox"/> Yes	<input type="checkbox"/> No	
Good biological activity		<input type="checkbox"/> Yes <input type="checkbox"/> No	Sludge return lines clear:		
			<input type="checkbox"/> Yes	<input type="checkbox"/> No	
<b>Treatment tank / chamber</b>					
<b>Aeration zone</b>					
Odour:		<input type="checkbox"/> Yes <input type="checkbox"/> No	pH:		Dissolved oxygen: mg/L
<b>Activated sludge</b>					
Activated sludge system		<input type="checkbox"/> Yes <input type="checkbox"/> No	Diffusers operating		<input type="checkbox"/> Yes <input type="checkbox"/> No
Air blower working		<input type="checkbox"/> Yes <input type="checkbox"/> No	Sufficient air supply		<input type="checkbox"/> Yes <input type="checkbox"/> No
Air blower noise		<input type="checkbox"/> Yes <input type="checkbox"/> No	Biofilm build up		<input type="checkbox"/> High <input type="checkbox"/> Normal
Air blower pressure OK		<input type="checkbox"/> Yes <input type="checkbox"/> No	Aeration timer / diffusers adjusted		<input type="checkbox"/> Yes <input type="checkbox"/> No
Air blower filter cleaned		<input type="checkbox"/> Yes <input type="checkbox"/> No	Air blower filter replaced		<input type="checkbox"/> Yes <input type="checkbox"/> No
<b>Colour of Effluent (tick one only)</b>					
<input type="checkbox"/> Dark brown (good)		<input type="checkbox"/> Light brown (insufficient aeration times)		<input type="checkbox"/> Dark grey (insufficient oxygen delivery)	
Suspended growth system			<input type="checkbox"/> Yes (conduct settleability test)		<input type="checkbox"/> No
<b>Settleability test</b>					
<input type="checkbox"/> Clear (good)		<input type="checkbox"/> Bulky (excess sludge accumulation)		<input type="checkbox"/> Turbid (short residence time and carry over)	

Checklist 7.2 continued					
Irrigation Chamber					
Irrigation pump operational	<input type="checkbox"/> Yes	<input type="checkbox"/> No	Float switches operational	<input type="checkbox"/> Yes	<input type="checkbox"/> No
Presence of sludge	<input type="checkbox"/> Yes	<input type="checkbox"/> No	Alarm operational	<input type="checkbox"/> Yes	<input type="checkbox"/> No
Disinfection					
Chlorine:	<input type="checkbox"/> Yes	<input type="checkbox"/> No	Turbidity:	NTU	
Chlorinator intact & operating:	<input type="checkbox"/> Yes	<input type="checkbox"/> No	<input type="checkbox"/> N/A		
No. tablets consumed:			No. tablets replaced:		
Free chlorine:					mg/L
Ultraviolet (UV):	<input type="checkbox"/> Yes	<input type="checkbox"/> No	Turbidity:	NTU	
Lamp cleaned:	<input type="checkbox"/> Yes	<input type="checkbox"/> No	<input type="checkbox"/> N/A		
Lamp replaced:	<input type="checkbox"/> Yes	<input type="checkbox"/> No	<input type="checkbox"/> N/A		
Electrical components					
Alarms tested:					
Water	<input type="checkbox"/> Yes	<input type="checkbox"/> No			
Air	<input type="checkbox"/> Yes	<input type="checkbox"/> No			
General condition	<input type="checkbox"/> Good	<input type="checkbox"/> Fair	<input type="checkbox"/> Poor		
Effluent Management Area					
Evidence of physical damage	<input type="checkbox"/> Yes	<input type="checkbox"/> No	Comments:		
Presence of surface ponding / runoff from the effluent irrigation area	<input type="checkbox"/> Yes	<input type="checkbox"/> No			
Excess weed growth in the area	<input type="checkbox"/> Yes	<input type="checkbox"/> No			
Effluent running into dam, stormwater drain or watercourse	<input type="checkbox"/> Yes	<input type="checkbox"/> No			
Surface Irrigation	Subsurface Irrigation		Trench / Bed / Mound		
Sprinkler heads fixed:	Operating pressure		Check surface ponding / toe leaching		
<input type="checkbox"/> Yes <input type="checkbox"/> No	<input type="checkbox"/> Good	<input type="checkbox"/> Poor	<input type="checkbox"/> Yes	<input type="checkbox"/> No	<input type="checkbox"/> N/A
Sprinkler heads working:	Lines back flushed:		Comments:		
<input type="checkbox"/> Yes <input type="checkbox"/> No	<input type="checkbox"/> Yes	<input type="checkbox"/> No			
Non-working sprinkler heads replaced:	Filter checked and cleaned:				
<input type="checkbox"/> Yes <input type="checkbox"/> No	<input type="checkbox"/> Yes	<input type="checkbox"/> No <input type="checkbox"/> N/A			
Sprinklers spraying in high-risk area:	Auto sequencing valve working:		Manual valves working:		
<input type="checkbox"/> Yes <input type="checkbox"/> No	<input type="checkbox"/> Yes	<input type="checkbox"/> No <input type="checkbox"/> N/A	<input type="checkbox"/> Yes	<input type="checkbox"/> No	<input type="checkbox"/> N/A
Sprinklers heads moved / valves switched to a different effluent irrigation area / trench / mound area:			<input type="checkbox"/> Yes	<input type="checkbox"/> No	
Check and clean filter:			<input type="checkbox"/> Yes	<input type="checkbox"/> No	<input type="checkbox"/> N/A

**Comments, action or repairs needed:** (Where a response in this checklist needs extra information or action, specify the action plan and/or the process to fix the problem, or specify an alternative that is being offered)

**Service provider:**

**Title:**

**Contact number:**

**Name of inspector:**

**Signature:**

**Date:**

## 7.6 Case study

A greywater treatment system (Figure 7.3) was installed at a residence as part of an extensive sustainable water management project. The greywater storage tank created unpleasant odours and the treated greywater, once filtered through the worm bed filter and UV disinfected, was stored in a 1,000 litre tank for toilet flushing and laundry reuse. The treated greywater stained the toilet bowl brown and left an off-white colour in white clothing in the washing machine.



### Problem

Storing greywater for any length of time can create unpleasant odours if it turns septic. Greywater should not be stored for more than 24 hours. However, this does not guarantee that odours will not be created in a shorter time. The organic material in the worm bed filter adds tannin to the greywater as it filters through the beds. This colour can stain the toilet bowl and clothing in the washing machine. The lack of a coarse screen filter allowed gross contaminants such as hair and lint into the storage tank for greywater destined for treatment and reuse.

Figure 7.3 Organic media from the GTS

### Solution

To avoid problems with odours, the greywater tank must be of a suitable size, and flows to the pre-treatment storage tanks must be regulated so that they are not collected and stored for enough time for odours to develop. Either some excess greywater should be diverted to a black water treatment system or sewer, or a treatment system that can better manage higher inflows should be chosen. The 1,000 litre pre-treatment storage tank is probably too large as it stores untreated greywater for too long before reuse.

To avoid staining from reuse of the treated greywater, consider an alternative non-staining filtration media, such as quartz sand. Greywater treated in a sand filter will usually be free of discolouration. The tannin in the greywater can make UV disinfection less effective, which has other health implications for human contact with the treated greywater. The greywater needs a higher level of treatment without discolouration to ensure the UV disinfection is effective.

The coarse screen filter should be replaced to effectively remove gross solids. The passage of gross solids to the greywater storage tank may have contributed to the poor water quality and odours. A sink strainer would offer a first line of defence to help remove solids.

## 8 Amended Soil Mounds

An amended soil mound (Figure 8.1) is designed to treat and dispose of primary or secondary effluent and further remove phosphorus, nitrogen and micro-organisms from the effluent. The soil used in this type of mound often contains an industrial by-product, which is high in iron and aluminium sesquioxides that have a high phosphorus adsorption capacity. Amended soil mounds are suitable for sites where there is limited area available for on-site effluent or where there is a high groundwater table or a sensitive surrounding environment. Septic tanks are the most common treatment system type used with amended soil mounds, but they may also be combined with an aerated wastewater treatment system, biological filter system or composting toilet.



Figure 8.1 An amended soil mound in the Blue Mountains

### 8.1 Design

Early amended soil mounds constructed in NSW had a mounded profile using many proven successful hydraulic concepts, with highly phosphorus sorptive material used in the mound to remove phosphorus from the effluent. The soil used in amended soil mounds has been modified to achieve a very high level of nutrient reduction. These mounds, constructed with an appropriately sized peripheral seepage trench have generally performed well in NSW.

More recently amended soil mounds have been constructed with a much flatter profile and a relatively thin sand bed beneath the amended soil bed. Figure 8.2 shows a cross section of such an amended soil mound. A number of the technical issues identified in Section 8.5 have been associated with the flatter profile mounds. Ensuring that upslope water is diverted and building the mound 'proud' of the natural ground surface addresses most of these issues.

Shallower or flatter mounds have less exposure to wind and consequently evapotranspiration is reduced. More hydraulic load must then be managed by seepage through the underlying sand bed that may on occasions become saturated due to insufficient intergranular pore storage. Hydraulic overloading is likely to cause toe seepage. Careful attention must be given to the linear loading rate. Longer and narrower amended soil mounds are more effective and less likely to suffer toe seepage.

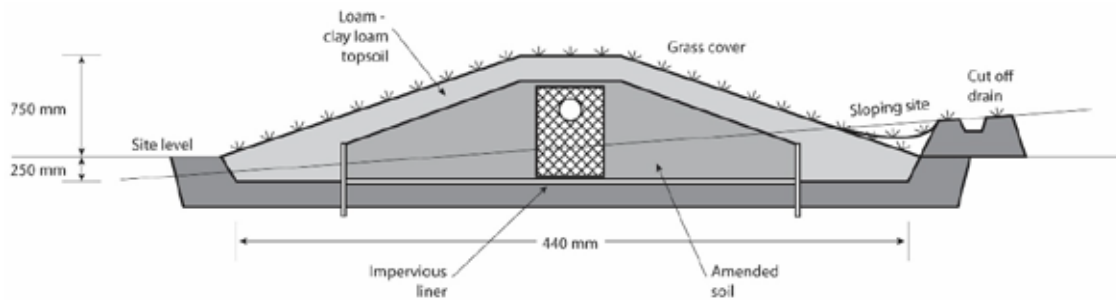

**Figure 8.2 Cross section of an amended soil mound**

The mound and basal seepage bed, or the peripheral absorption trenches, should be sized based on an appropriate hydraulic balance with careful consideration of the site and soil conditions and the available storage in the underlying sand bed or absorption trench. This is important to provide enough storage for wet periods when less effluent is taken up by evapotranspiration. When calculating the hydraulic loading rate for the hydraulic balance for a mound that is cut into sloping ground, consider the lower hydraulic conductivity of the deeper soil layers on the upslope side of the mound.

Basal loading rates should be determined based on any soil limiting layer within 600 millimetres beneath the base of the underlying sand layer.

Cutting into the slope can also result in a very thin separation distance between the base of the bed and the limiting layer, especially where soil is already shallow. The system can fail due to poor understanding of the hydraulic effect of placing it on shallow soils. For this reason, WaterNSW generally only accepts amended soil mounds on sites where the slope is less than seven percent (four degrees). WaterNSW may, on a case-by-case basis, consider amended soil mounds for slopes that are 7 to 10.5% (4-6°) if the mound bench is built up with consolidated topsoil and not cut into the slope. In all cases a detailed hydraulic balance which appropriately considers local climate, linear loading rate, storage and basal loading rate(s) for the underlying soil(s) must be presented to demonstrate the sustainability of the design.

## 8.2 Installation

A mound must be installed properly, as poor installation techniques often result in system failure. It is recommended that experienced practitioners design and construct the amended soil mound following the steps below. System installers and Council inspectors can use Checklist 8.1 to check the amended soil system is correctly installed.

### Step 1 Site selection

A suitable site must be chosen for an amended soil system. It should be adequate for construction of the mound without undue cutting into the existing slope. The site should allow any upslope drainage to be appropriately diverted around the amended soil mound to stop the treatment cell from becoming saturated with run-on stormwater. Diversion drains, as shown in Standard Drawing 1 (Appendix 4), should be constructed to divert run-on water from upslope.

The treatment cell and underlying sand bed should not be cut into the slope to the extent that it intersects groundwater. This could allow groundwater to seep into the underlying sand bed and cause hydraulic overload or penetrate the treatment cell liner and add to the hydraulic load being treated within.

By cutting the treatment cell and underlying sand bed into a slope, the upslope portion of the underlying sand bed will probably be on soil with a significantly lower hydraulic conductivity than that under the downslope side of the bed. This can cause uneven hydraulic loading of the soil beneath the underlying sand bed and can cause toe seepage from the overloaded downslope side of the mound.

## Step 2 Site layout

Set out the base dimension of the mound on the ground and start to excavate the area (Figure 8.3). The liner of the treatment cell must be level and on homogenous soil to ensure that effluent passes evenly out through the treatment cell from the central leach drain. If the sand bed later experiences uneven settlement, the form of the liner could become uneven and cause effluent to pass preferentially through only part of the treatment cell. This has implications for detention time, phosphorus removal and overall treatment. It could concentrate the hydraulic load at one part of the mound and make hydraulic failure more likely. Amended soil mound systems should not be built on unconsolidated fill.



Figure 8.3 Excavation/preparement of base of mound (Figures 8.3-8.7 Ecomax, 2001)

## Step 3 Construction

- Erect the cell boundary framework.
- Line the base of the mound with construction membrane to protect from root incursion or rocks, as shown in Figure 8.4.
- Line the base of the mound with an impervious liner, as shown in Figure 8.5, to contain the amended soil mixture.
- Position the effluent tunnel in the centre of the cell area and wrap in fabric to prevent ingress of soil.



Figure 8.4 Construction membrane



Figure 8.5 Lining with an impervious liner

#### **Step 4 Backfilling**

Spread amended soil over the liner and install a distribution tunnel, as shown in Figures 8.6 and 8.7. In more clay rich soils, ensure that there is enough granulated phosphorus sorbing material to increase the hydraulic conductivity of the soil in the treatment cell. This will help transmission and reduce the chance of waterlogging of the treatment cell and surcharging to the surface. It is important to ensure that the phosphorus sorptive material is blended uniformly with the soil to avoid clumping of potentially cementitious material.



**Figure 8.6 Backfilling with amended soil**



**Figure 8.7 Final shaping of cell mound**

#### **Step 5 Completion**

Spread topsoil and turf over the mound ensuring that batter grades are as per the design, as shown in Figure 8.1. The mound must be capped with a soil of moderate permeability (e.g. loam to clay loam) to minimise rainfall infiltration and promote evapotranspiration. Constructing the mound with reduced batter slopes, or a flat bed, reduces the provision for diversion of incident rainfall from the top surface of the mound and adds to the hydraulic load on the treatment cell. The treatment cell should always be constructed with two capped, slotted inspection pipes inserted in the base of the cell, one on either side of the leach drain.

Fence off the mound area to protect it from livestock and other animals (e.g. dogs and rabbits) and vehicles.

Construct a stormwater diversion berm / drain before finishing the mound. Stormwater diversion should be constructed according to Standard Drawing 1 (Appendix 4).

### 8.3 Inspection

Council should inspect the tank and all associated pipe and drainage work before backfilling to ensure that all components are in the correct position and installed according to the [ABCN National Construction Code \(NCC\) Series Volume Three – Plumbing Code of Australia](#) (Commonwealth of Australia, and the States and Territories of Australia 2022, published by the Australian Building Codes Board). Council should inspect the final installation to ensure it complies with all conditions of consent before issuing an approval to operate the system.

### 8.4 Operation

The owner should inspect the mound regularly. This detailed maintenance inspection should include:

- switching treatment cells every six months
- checking any pumps are operating correctly. If the system includes a standby pump, it should be swapped with the operating pump regularly to ensure that the work hours on both are approximately equal
- checking the surrounds of the mound, especially downslope, for signs of leakage
- checking the inspection ports of the mound for water level, to ensure the mound is not internally flooded.

The owner of the system also has general maintenance and operational tasks to carry out, including:

- ensuring all products used in the household are safe for the system (bleaches and many household cleaning products are not)
- managing the vegetation around the tank and mound (this includes mowing and trimming bushes for maximum exposure)
- for a septic tank, inspecting and cleaning the outlet filter every three months
- checking the septic tank sludge depth levels regularly
- contacting a plumber as soon as practicable if a pump well or other alarm activates
- continuing other maintenance requirements for an aerated wastewater treatment system or a biological filtration system where they are used together with an amended soil mound.

Checklist 8.2 lists items that should be checked during a regular maintenance inspection for an operational amended soil mound. The system owner and Council compliance inspectors can use this checklist.

Installation checklists for effluent management systems are also included in Sections 10 – Absorption trenches and beds, 11 – Evapotranspiration absorption beds, 12 – Surface irrigation and 13 – Subsurface irrigation.

Checklist 8.1 Installation of mound for use by plumbers and Council inspectors	
Owner's name:	
Address:	
Installation date:	
Mound coordinates:	
Is the mound positioned according to council and WaterNSW requirements for buffer distances?	<input type="checkbox"/> Yes <input type="checkbox"/> No
Is the mound positioned according to Council and WaterNSW design requirements for contours and slope?	<input type="checkbox"/> Yes <input type="checkbox"/> No
Have at least two inspection ports been incorporated into the mound?	<input type="checkbox"/> Yes <input type="checkbox"/> No
Is the installed switching valve readily accessible?	<input type="checkbox"/> Yes <input type="checkbox"/> No
Is there an indication of poor drainage on or near the mound area?	<input type="checkbox"/> Yes <input type="checkbox"/> No
Has a diversion berm / drain been installed above the mound?	<input type="checkbox"/> Yes <input type="checkbox"/> No
Has the mound been protected to prevent mound damage (e.g. using fencing)?	<input type="checkbox"/> Yes <input type="checkbox"/> No
Has a turfed cover been established over the mound surface?	<input type="checkbox"/> Yes <input type="checkbox"/> No
Does the mound have good exposure to wind and sun?	<input type="checkbox"/> Yes <input type="checkbox"/> No
Are the mound dimensions and construction requirements consistent with council's conditions of consent?	<input type="checkbox"/> Yes <input type="checkbox"/> No
Mound length (m):	Mound width (m):
No. of cells:	
Does the mound include any non-standard elements in its design?	<input type="checkbox"/> Yes <input type="checkbox"/> No
If yes, describe:	
Note: the checklist for the septic tank and any pump well will also need to be completed	
<b>Comments, action or repairs needed:</b> (Where a response in this checklist needs extra information or action, specify the action plan and/or the process to fix the problem, or specify an alternative that is being offered)	
<b>Service provider:</b>  <b>Title:</b>  <b>Contact number:</b>	
<b>Name of inspector:</b>	
<b>Signature:</b>	<b>Date:</b>

<b>Checklist 8.2 Operational mound system inspection report for use by councils and system owners</b> (Note: system includes septic tank and pump well plus mound)			
Owner's name:			
Address:	Council area:		
Installation date:			
Tank coordinates:	Mound coordinates:		
System brand and model:	<input type="checkbox"/> Domestic <input type="checkbox"/> Commercial		
Date of service:	Date of last service:	Next service due:	
General Comments			
General condition of tank	<input type="checkbox"/> Good	<input type="checkbox"/> Fair <input type="checkbox"/> Poor	
Comments:			
Septic Tank			
Crust:	<input type="checkbox"/> Yes <input type="checkbox"/> No	Odour:	<input type="checkbox"/> Yes <input type="checkbox"/> No
Sludge depth:	<input type="checkbox"/> High <input type="checkbox"/> Med <input type="checkbox"/> Low	Desludge needed:	<input type="checkbox"/> Yes <input type="checkbox"/> No
Inlet/outlet junctions clear:	<input type="checkbox"/> Yes <input type="checkbox"/> No	Good biological activity	<input type="checkbox"/> Yes <input type="checkbox"/> No
Pump well (where installed)			
Pump operational	<input type="checkbox"/> Yes <input type="checkbox"/> No	Float switches operational and set at appropriate levels	<input type="checkbox"/> Yes <input type="checkbox"/> No
Presence of sludge	<input type="checkbox"/> Yes <input type="checkbox"/> No	Standby pump switched (if relevant)	<input type="checkbox"/> Yes <input type="checkbox"/> No
Electrical components			
Alarm operational	<input type="checkbox"/> Yes <input type="checkbox"/> No		
Electrical compartment in good working order	<input type="checkbox"/> Yes <input type="checkbox"/> No		
Mound			
Evidence of physical damage (e.g. digging, erosion)	<input type="checkbox"/> Yes <input type="checkbox"/> No		
Comments:			
Presence of surface ponding / toe leaching / seepage	<input type="checkbox"/> Yes <input type="checkbox"/> No		
Excess weed growth on mound and in the area	<input type="checkbox"/> Yes <input type="checkbox"/> No		
Incomplete or inappropriate vegetation cover	<input type="checkbox"/> Yes <input type="checkbox"/> No		
Valves working	<input type="checkbox"/> Yes <input type="checkbox"/> No		
Have the cells been switched?	<input type="checkbox"/> Yes <input type="checkbox"/> No		

Inspection port interiors clear (i.e. no standing water suggesting internal flooding) and in good condition  Yes  No

**Checklist 8.2 continued**

**Comments, action or repairs needed:** (Where a response in this checklist needs extra information or action, specify the action plan and/or the process to fix the problem, or specify an alternative that is being offered)

**Service provider:**

**Title:**

**Contact number:**

**Name of inspector:**

**Signature:**

**Date:**

## 8.5 Common technical issues

Plumbers, property owners and regulatory authorities have observed a number of common problems with amended soil mound installations, including:

- not installed as per the approved design and specification
- installing mounds on too steeply sloping sites, with the upslope side of the mound cut into low hydraulic conductivity subsoils
- intersection of groundwater flow by cutting into the slope to form a level base for the mound
- building the mound too flat, limiting the amount of rainfall that is shed from the mound
- building the mound too flat and relying too much on seepage and only limited evapotranspiration
- building the mound too short along the contour due to poor understanding of the linear loading rates
- uneven distribution across the mound / not switching between treatment cells
- mound toe leakage
- poor vegetation cover
- undersizing.

## 8.6 Case study

An amended soil mound was built on a sloping site with shallow soil (Figure 8.9). The mound was built into the hillside using a cut and fill construction technique. The upslope part of the mound is likely on bedrock and the downslope part is on unconsolidated fill. As a result, the soil under the mound is of variable strength and hydraulic capacity.

The lower hydraulic conductivity of the soil under the upslope portion of the mound will tend to force effluent downslope. Effluent will seep to the bottom of the mound where it is more likely to overload the soil beneath.

The relatively high transmissivity of the fill, compared to the shallow natural soil beneath, can cause toe seepage. This hydraulic overload of the mound could be made worse by stormwater flowing onto the mound from upslope.

### Problem

The problems are a lack of adequate stormwater diversion, excessive hydraulic load due to stormwater, uneven basal loading under mound, uneven settlement under mound, and toe seepage.

### Solution

Build enough diversion drainage around the upslope margin of the amended soil mound (see Standard Drawing 1 – Appendix 4). Where possible avoid excessive excavation into the hill slope to build the mound to reduce the chance of intersecting lower hydraulic conductivity soils. Form the basal soakage bed on soils of uniform characteristics (but not unconsolidated fill). Calculate the basal loading rate based on these sub-soils (i.e. use a lower value). If toe seepage is a concern, extend the mound out in the downslope direction and use an appropriately low linear loading rate for the mound.

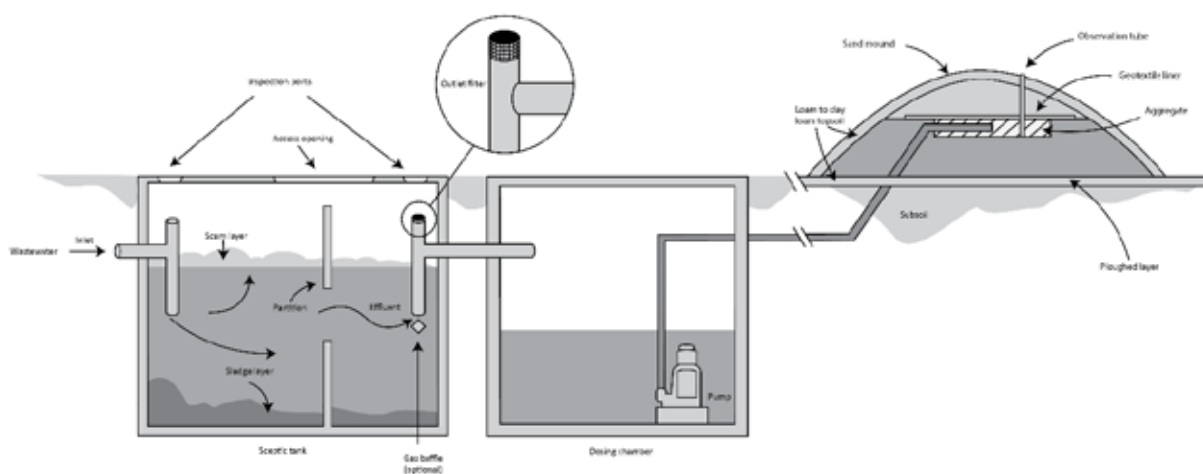

Figure 8.9 Amended soil mound constructed on sloping site

## 9 Sand Mounds

The sand mound (often called a Wisconsin mound) is used to treat and dispose of domestic wastewater in areas that are unsuitable for conventional septic tank soil absorption systems due to shallowness, high water table, low permeability, or prior disturbance. They can also be used even where these constraints do not exist.

The Wisconsin sand mound system (Figure 9.1) includes a septic tank, a dosing chamber, and a mound made of sand fill above the soil surface. It is essentially a combination of a single pass sand filter and dispersal unit (Converse and Tyler, 2000). Septic tank effluent is distributed in even and timed doses into the mound via a dosing chamber or pump well. Wastewater is treated as it moves through the sand mound, then further treated and then dissipated in the soil underneath the mound.



**Figure 9.1** Components of a Wisconsin sand mound system

A level area is best for building Wisconsin sand mounds, but a gently sloping site will also work. On sloping sites, the mound is built along the contour of the land, and the width of the toe will increase with increasing slope.

### 9.1 Design

Many of the considerations for designing a sand mound described below are based on 'Wisconsin Mound Soil Absorption System: Siting Design and Construction Manual' (Converse and Tyler, 2000).

Successful mound performance depends on several design and location factors. There must be some type of screen (such as a septic tank outlet filter) to stop small particles from entering the sand mound. Small particles in the sand media can clog the pore spaces and make the mound less effective. Sand quality also affects performance and the distribution of grain sizes (and hence the pore size) is an essential design factor. [AS/NZS 1547:2012 On-site domestic wastewater management](#), sets out the effective size and uniformity coefficient for mound sand. The size of sand mounds should be based on Converse and Tyler (2000) and design loading rates in Table N1 of [AS/NZS 1547:2012](#).

Mound sand and the underlying soil beneath the mound to a depth of 200 millimetres are blended in even proportions to create a gradational transition from the mound to the underlying soil. The mound is then constructed with a minimum thickness of 600 millimetres of select sand. If the mound is constructed on sloping ground this thickness will be greater under the lower side of the mound.

The distribution system normally consists of small diameter drilled pipes that allow wastewater to be evenly applied under low pressure in the mound. A pressure distribution network is essential to distribute the septic tank effluent. Gravity flow is unacceptable as it will not distribute the effluent evenly over the infiltrative surface or along the length of the mound.

Three critical aspects of loading rate are important in mound design. The loading rate onto the sand at the base of the aggregate bed, the linear loading rate and the basal loading rate onto the underlying soil are set out in [AS/NZS 1547:2012](#) and should be strictly adhered to.

Dosing is important for effective function of the mound system. Short frequent doses of effluent (timed dosing) onto sand filters with closely spaced openings are preferred as they help improve effluent quality. Demand dosing, where large amounts of effluent are applied at once, causes effluent to pass more rapidly through the sand, and does not allow sufficient time for effective treatment.

Distribution beds should incorporate a valve set within a turf box in the mound top. This should include a shut off valve, an air admittance valve and squirt point. Beds larger than 8m should have two sets providing two feed points at 1/3 and 2/3 distance of the length. This allows flushing to either end. The end manifolds should include a flush tee which leads to a flush valve at both end toes of the mound in a turf box.

The distribution pipe work includes a squirt hole point which should be measured at commissioning of the mound. An increase in the height would indicate blocking of the distribution pipework. The squirt hole can be located in the valve set turf box or a separate turf box. Distribution bed pipe work should be hydraulically designed to ensure adequate and even distribution through all pipework orifices. The squirt height should not vary by more than 10% along the length of the mound. Squirt height should be at least 1 metre and it is critical that an appropriately sized pump be used to ensure effective distribution. The distribution pipe work should be able to drain out between doses. This is commonly achieved by drilling one downward facing hole at the most distant end of each distribution lateral.

## 9.2 Installation

A Wisconsin sand mound must be installed properly, as poor installation techniques often cause these systems to fail. An experienced practitioner should design and build a Wisconsin sand mound. The following steps should be used to install a Wisconsin sand mound.

### **Step 1**                    **Site selection and layout**

Establish the contour of the lot and mound area. Stake out the mound so that the distribution cell runs parallel to the contour. Mounds must be on the contour to maintain constant mound height and ensure effluent is evenly distributed.

The site should be one where any upslope drainage can be appropriately diverted around the sand mound to stop it from becoming saturated with run-on stormwater. A diversion berm / drain, as shown in Standard Drawing 1 (Appendix 4), should be built to divert run-on water from upslope. Consider where the effluent pipe from the pump well to the sand mound will be located.



**Figure 9.2**      **Excavation/preparation of base of mound**

## **Step 2**      **Construction**

Create a trench and lay the effluent pipe from the pump well to the mound site according to the [ABCB National Construction Code \(NCC\) Series Volume Three – Plumbing Code of Australia](#) (Commonwealth of Australia, and the States and Territories of Australia 2022, published by the Australian Building Codes Board). Cut and cap the pipe 300 millimetres beneath the ground surface. Lay the pipe sloping evenly back to the pump well so that it drains after dosing. Backfill and compact the soil around the pipe to stop effluent seeping back along the pipe.

Prepare the mound site by clearing all shrubs, trees and boulders. Cut any trees to ground level and then grind the stump out to a depth of 300 millimetres and backfill with permeable material such as the natural topsoil or sand (not clay). Scarify the natural soils along the contour across the entire basal area to a minimum depth of 200 millimetres taking care not to compact the basal area in the process. This should extend at least one metre beyond the mound perimeter and two metres on the downhill side. For a depth of 200 millimetres beneath the mound, blend mound sand and soil in equal proportions to allow a gradational change from the mound to the soil beneath.

If the soil is too wet, there will be smearing and compaction during site preparation, reducing the infiltration capacity of the soil and ultimately the mound's effectiveness. If the site is too wet, it is essential to wait until the soil has dried out sufficiently.

Perform all work from the upslope side to avoid compacting the downslope area, especially if effluent flows horizontally away from the mound (Converse and Tyler, 2000).

Decide where the distribution pipe from the pump chamber enters the mound. An upslope centre feed is better for long mounds. Lay the pipe with an even slope back to the chamber so that it drains after dosing.

The mound must have observation tubes extending from the infiltrative surface to or above the ground surface to allow observation of any ponding at the infiltrative surface. Place the tubes at approximately  $\frac{1}{4}$  and  $\frac{3}{4}$  points along the length of the distribution cell.

Use the following points for good construction techniques:

- Place the proper depth of sand then form the distribution area with the bottom area raked level
- Place washed, sound aggregate to a depth of approximately 100 millimetres
- Place the pressure distribution network with drilled holes located upward and pressure test the system for uniformity of flow
- Cover the distribution network pipes with agricultural (Ag) pipe
- Cover the distribution network with approximately 100 millimetres of aggregate
- Cover the aggregate with geotextile synthetic fabric.



Figure 9.3 Placing sand



Figure 9.4 Constructing the manifold



Figure 9.5 Gravel over inlet manifold



Figure 9.6 Sand on top of geotextile fabric

### Step 3 *Completion*

Use the following techniques to complete the installation:

- Cap the distribution cell with at least 300 millimetres of topsoil and shape to create the profile of the mound
- At least 150 millimetres of topsoil must be placed over the entire mound
- Cap the mound with moderately permeable soil (e.g. loam to clay loam) to minimise rainfall infiltration and promote evapotranspiration. The soil should be garden quality topsoil and free of coarse fragments. The mound must be able to breathe to allow oxygen to diffuse into and below the absorption area.
- Final grade the mound area so surface water moves away from and does not accumulate on the up slope side of the mound. The recommended side slopes ratio for mowing safety is 3 horizontal:1 vertical.

- The mound must be turfed immediately after finishing construction. Maintain a vegetated buffer around the area that extends two metres on the upslope side and four metres on the downslope side.
- The mound area must be appropriately fenced-off or protected from livestock, other animals (e.g. dogs and rabbits) and vehicles.



Figure 9.7 Turfing the mound

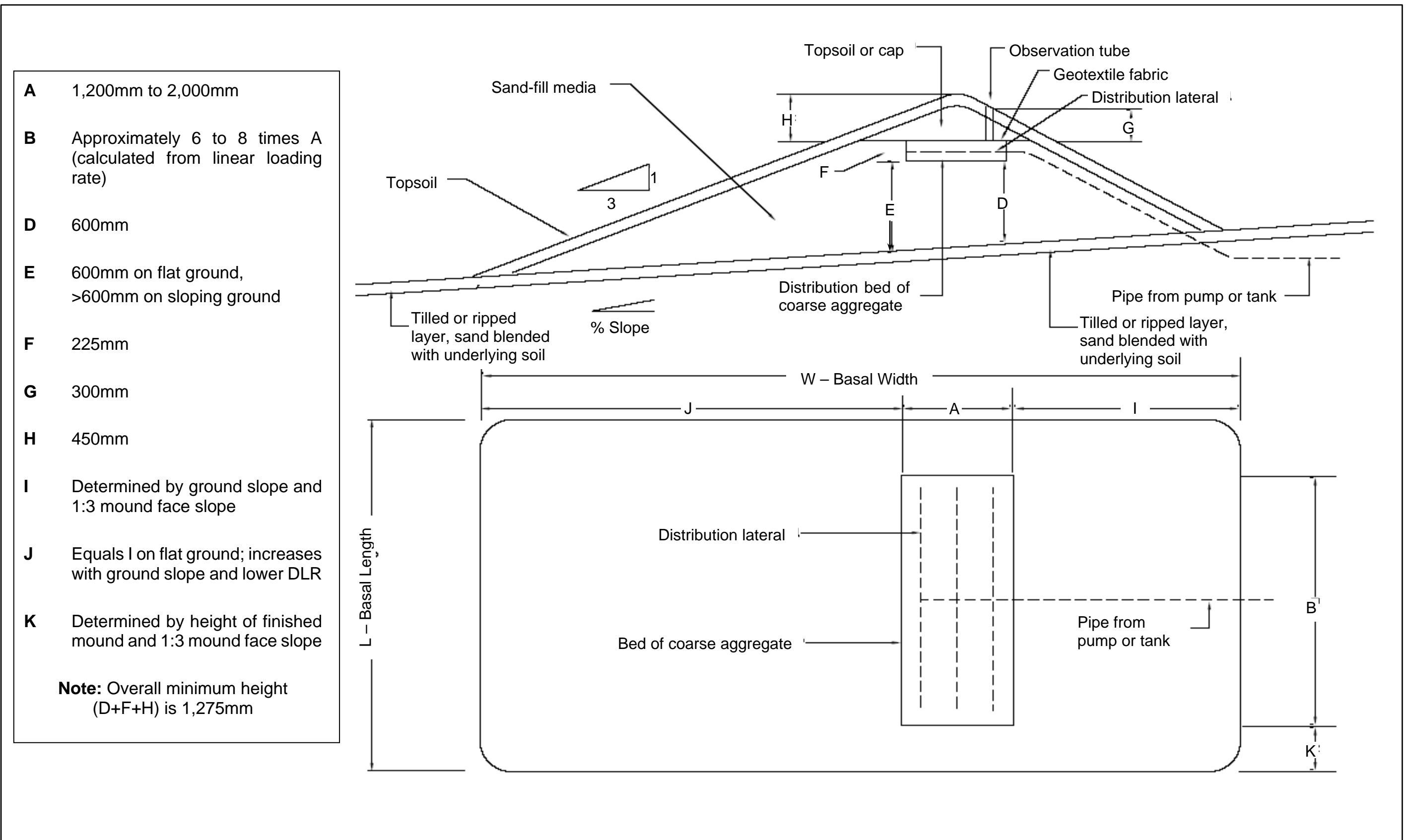

**Standard Drawing 9A – Wisconsin Sand Mound**  
(not to scale)

### 9.3 Inspection

A Council inspector should inspect the septic tank, pump well, mound distribution cell and all associated pipe and drainage work before backfilling, to ensure all components are correctly positioned and installed according to the [ABCB National Construction Code \(NCC\) Series Volume Three – Plumbing Code of Australia](#) (Commonwealth of Australia, and the States and Territories of Australia 2022, published by the Australian Building Codes Board). Council should make a final installation inspection to ensure compliance with all conditions of consent, before issuing an approval to operate the system.

### 9.4 Operation

The owner should inspect the mound regularly, including:

- checking any pumps are operating correctly. If the system includes a standby pump, it should be swapped with the working one regularly to ensure that the work hours on both are approximately equal
- checking the mound for signs of leakage (soggy spots or seepage on the top or side slopes or toe areas of the mound)
- checking the inspection ports of the mound for standing water, to ensure the mound is not internally flooded.

The owner should also perform a number of general maintenance tasks, including:

- minimising the use of products in the household that are unsafe for the system (bleaches and many household cleaning products are unsafe)
- managing the vegetation around the tank and mound (including mowing the grass)
- ensuring power is continuously available and switched on
- ensuring that a plumber is contacted as soon as practicable if an alarm activates.

System installers and Council inspectors can use Checklist 9.1 to ensure the sand mound is correctly constructed.

Checklist 9.2 outlines items that should be checked during a regular maintenance inspection for an operational Wisconsin sand mound. This checklist can be used by the owner of the system and also for council compliance inspections.

Checklist 9.1 Installation of mound for use by plumbers and Council inspectors	
Owner's name:	
Address:	
Installation date:	
Mound coordinates:	
Is the mound positioned according to council and WaterNSW requirements for buffer distances?	<input type="checkbox"/> Yes <input type="checkbox"/> No
Is the mound positioned according to Council and WaterNSW design requirements for contours and slope?	<input type="checkbox"/> Yes <input type="checkbox"/> No
Have at least two inspection ports been incorporated into the mound?	<input type="checkbox"/> Yes <input type="checkbox"/> No
Is there an indication of poor drainage on or near the mound area?	<input type="checkbox"/> Yes <input type="checkbox"/> No
Has a diversion berm / drain been installed above the mound?	<input type="checkbox"/> Yes <input type="checkbox"/> No
Has the mound been protected to prevent mound damage (e.g. by fencing)?	<input type="checkbox"/> Yes <input type="checkbox"/> No
Has a turfed cover been established over the mound surface?	<input type="checkbox"/> Yes <input type="checkbox"/> No
Does the mound have good exposure to wind and sun?	<input type="checkbox"/> Yes <input type="checkbox"/> No
Are the mound dimensions and construction requirements consistent with council's conditions of consent?	<input type="checkbox"/> Yes <input type="checkbox"/> No
Mound length: _____ m	Mound width: _____ m
Does the mound include any non-standard elements in its design?	<input type="checkbox"/> Yes <input type="checkbox"/> No
If yes, describe:	
Note: the checklist for the septic tank and any pump well will also need to be completed	
<b>Comments, action or repairs needed:</b> (Where a response in this checklist needs extra information or action, specify the action plan and/or the process to fix the problem, or specify an alternative that is being offered)	
Service provider:	
Title:	
Contact number:	
Name of inspector:	
Signature:	Date:

<b>Checklist 9.2 Operational mound system inspection report for use by councils and system owners</b> (Note: system includes septic tank and pump well plus mound)			
Owner's name:			
Address:		Council area:	
Installation date:			
Tank coordinates:		Mound coordinates:	
System brand and model:		<input type="checkbox"/> Domestic <input type="checkbox"/> Commercial	
Date of service:	Date of last service:	Next service due:	
General Comments			
General condition of tank		<input type="checkbox"/> Good <input type="checkbox"/> Fair <input type="checkbox"/> Poor	
Comments:			
Septic Tank			
Crust:	<input type="checkbox"/> Yes <input type="checkbox"/> No	Odour:	<input type="checkbox"/> Yes <input type="checkbox"/> No
Sludge depth:	<input type="checkbox"/> High <input type="checkbox"/> Med <input type="checkbox"/> Low	Desludge needed:	<input type="checkbox"/> Yes <input type="checkbox"/> No
Inlet/outlet junctions clear:	<input type="checkbox"/> Yes <input type="checkbox"/> No	Good biological activity	<input type="checkbox"/> Yes <input type="checkbox"/> No
Pump well (where installed)			
Pump operational	<input type="checkbox"/> Yes <input type="checkbox"/> No	Float switches operational and set at appropriate levels	<input type="checkbox"/> Yes <input type="checkbox"/> No
Presence of sludge	<input type="checkbox"/> Yes <input type="checkbox"/> No	Standby pump switched (if relevant)	<input type="checkbox"/> Yes <input type="checkbox"/> No
Electrical components			
Alarm operational		<input type="checkbox"/> Yes <input type="checkbox"/> No	
Electrical compartment in good working order		<input type="checkbox"/> Yes <input type="checkbox"/> No	
Mound			
Evidence of physical damage (e.g. digging, erosion) Comments:		<input type="checkbox"/> Yes <input type="checkbox"/> No	
Presence of surface ponding / toe leaching / seepage		<input type="checkbox"/> Yes <input type="checkbox"/> No	
Excess weed growth on mound and in the area		<input type="checkbox"/> Yes <input type="checkbox"/> No	
Incomplete or inappropriate vegetation cover		<input type="checkbox"/> Yes <input type="checkbox"/> No	

**Checklist 9.2 continued**

**Comments, action or repairs needed:** (Where a response in this checklist needs extra information or action, specify the action plan and/or the process to fix the problem, or specify an alternative that is being offered)

**Service provider:**

**Title:**

**Contact number:**

**Name of inspector:**

**Signature:**

**Date:**

## 9.5 Common technical issues

Figure 9.8 shows a cross section of a Wisconsin sand mound highlighting potential problems and common technical issues including:

- not installed as per the approved design and specification
- lack of familiarity with the installation of the system
- installation on too steeply sloping sites, with the upslope side of the mound cut into low hydraulic conductivity subsoils
- intersection of groundwater flow by cutting into the slope to form a level base for the mound
- building the mound too flat, limiting the amount of incident rainfall that is shed from the system
- building the mound too short along the contour due to poor understanding of the linear loading rate
- uneven distribution across and along the mound (lack of hydraulic design of manifold)
- water in the observation tubes caused by plugging of the soil distribution cell or excessive loading
- mound toe leakage caused by slowly permeable soil, compaction or soil damage during construction, or overloading of system, or downslope basal width too short (too high a linear loading rate)
- seepage of raw sewage on side or top of mound caused by plugging of the soil absorption area, overloading the system or using too fine sand as fill
- choosing inappropriate materials including inappropriate sand particle size distribution
- under sizing.

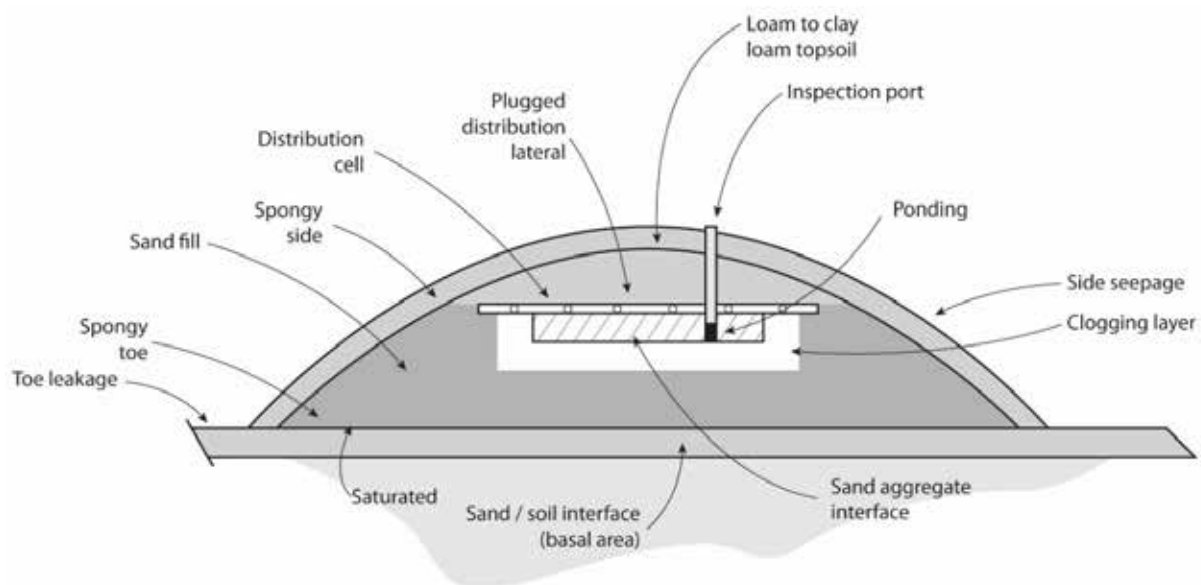

Figure 9.8 Cross section of a Wisconsin sand mound showing potential problems (after Converse and Tyler, 1987)

## 9.6 Case study

A Wisconsin sand mound was built on a sloping site with shallow soil. It was built into the hillside by cut and fill. During a routine maintenance inspection, high water levels were observed in the inspection ports indicating ponding at the sand / aggregate interface. The ponding remained after dosing and was therefore considered permanent ponding which can cause failure.

Permanent ponding can be caused by a clogging mat at the sand / aggregate interface due to excessive effluent hydraulic loads and/or sand fill that is too fine. There was also not enough stormwater diversion which caused saturation from run-on.

The solution was to first to check the sludge level in the septic tank and pump the septic tank out to reduce sludge carry-over.

Adequate diversion drainage was constructed around the upslope margin of the sand mound (see Standard Drawing 1 – Appendix 4). Where possible avoid excessive excavation into the hill slope for sand mound construction.

A water efficiency program was started for the dwelling, resulting in reduced hydraulic loads. If this was not enough to overcome the ponding problem, the mound may have needed to be resized and expanded. The mound cap should be removed and the aggregate in the absorption bed stripped out. The organic matter should be removed and the distribution laterals re-laid. The area downslope of the mound should be tilled or ripped, and additional fill added to enlarge the mound to the proper size. The absorption bed can then be rebuilt.

Alternatively, highly pre-treated effluent could be introduced to the mound by installing an aerobic unit or equivalent between the septic tank and the pump well (Converse and Tyler, 2000).

Soon after building the sand mound, the pump was running continuously with no apparent drop in the liquid level in the dose tank. The continuous pumping with no distribution of wastewater to the mound indicates clogging of the distribution laterals.

The solution was to fit an outlet filter to stop particulate material clogging the distribution cell and laterals. The end caps to the distribution laterals were removed and the solids flushed out using a high-volume, high-pressure pump. The laterals were recapped, and water or air forced into the distribution system to unplug the holes.

## 10 Absorption Trenches and Beds

In a conventional septic tank and absorption system, wastewater is gravity-fed or pumped from the septic tank to the absorption area. Trenches or beds (hereafter 'trenches' refers to 'trenches and beds') are usually built below ground and can be media-filled or consist of a durable self-supporting arch resting on gravel (or occasionally coarse sand). Trenches are usually relatively narrow and deep, while beds are wider and shallower.

NSW Health requires non-disinfected effluent to be disposed of at a soil depth more than 300 millimetres for both trenches and beds (NSW Health, 2017). Trenches are usually 500 to 700 millimetres deep and up to around 600 millimetres wide. Beds are usually no deeper than 600 millimetres, but up to several metres wide and contain a number of distribution pipes or arches. The depth and overall basal area depend on soil type and anticipated wastewater volume, climate and site features.

In septic tank and absorption trench systems, household wastewater first flows into a primary septic tank where solids settle to the bottom of the tank to form a sludge layer, and grease and fat float to the surface to form a scum layer. Clarified effluent then flows (or is pumped via a pump well) to the absorption trench or bed for treatment and disposal. The effluent is typically distributed along the length of the trench or bed through slotted or drilled 100 millimetre distribution pipes, and then filtered through the gravel and sand to the underlying soil. Pressure dosing, using a pump or other low pressure dosing device ensures more even distribution of effluent over the whole trench length and is increasingly employed in preference to feeding by gravity. A clogging layer or biomat develops along the bottom and sides of the trench and acts as a further filter. This filtering process helps remove pathogens, toxins and other pollutants.

Nutrients in the effluent are taken up by vegetation (normally grass) planted across the absorption trench area, incorporated in the biomat, and, in the case of phosphorus, adsorbed onto clay particles in the soil. Where trenches are gravity fed, the concentration of effluent loaded onto the near end of the trench results in progressive, or creeping development of the clogging layer, which pushes the point of application along the trench with time and results in the trench loading rate being concentrated on just part of the trench. This leads to shortened trench life by comparison with pressure dosed trenches where the even distribution of effluent allows the trench to recover more readily between doses.

Absorption trenches and beds are typically used to manage primary treated effluent. They can also be used to manage secondary treated effluent, in which case higher loading rates are acceptable, as outlined in ['AS/NZS 1547:2012 On-site domestic wastewater management'](#). Absorption trenches or beds used together with secondary treated effluent are small footprint systems. They are often used where there is limited space available for effluent management.

### 10.1 Design

The design of an absorption trench should consider the site and soil assessment outlined in Section 2. The absorption trench should be sized according to the recommendations of ['AS/NZS 1547:2012 On-site domestic wastewater management'](#). Installing absorption trenches requires council approval under the *Local Government Act 1993*. The trench must comply with council and WaterNSW requirements for buffer distances and setbacks from significant site features. The following points should also be considered.

- The maximum number of trenches for any one design is 10.
- Trench lengths should be designed to ensure that effluent is evenly distributed and reaches the far end of each trench. Individual trenches must be less than 20 metres for passive systems, or 25 metres for pressure dosed trenches.
- The linear loading rate is critical where soil is shallow (see Section 2 of this Manual).

- Where more than one trench is needed, trench lengths should be equal and effluent should be distributed evenly via a splitter box (Figure 10.1) or sequencing valve (Figure 10.2).



Figure 10.1 Splitter box



Figure 10.2 Sequencing valve

- Distribution pipes and arches should be laid according to manufacturer's instructions.
- It is better for trenches or beds to be pressure dosed instead of allowing the effluent to trickle into the trench or bed. This provides better and more even distribution along the whole trench while prolonging the life of the trench. A suitable pump or low pressure dosing device is needed to ensure that there is enough pressure to fully and evenly dose the trench or trenches.
- Inspection ports of 50 millimetre pipe, slotted at the trench base and capped at the top, should be inserted in each trench to allow inspection of the trenches once in operation.
- To prevent flooding of the septic tank, the ground surface level of the trench or bed must be at least 150mm below the invert of the septic tank outlet.
- Entry to a trench or bed should be by way of a 100mm DWV (drain, waste, vent) tee entering through the top of the trench with doses through the side of the tee. The top should be finished at ground with a Bolted Trap Screw (BTS) to enable inspection of the flow and the trench.
- Beds and trenches fed by secondary effluent should be monitored for root intrusion and the fitment of a root inhibitor emitter or annual treatment should be considered.
- WaterNSW will not support any design where the absorption trenches or beds are added in series (i.e. end on end).
- If a siphon (Figure 10.3), other dosing device such as a Flout (Figure 10.4), or pump (Figure 10.5) is used or required to pressure-dose trenches then a separate pump or dosing well is needed. NSW Health requires a pump well to be of at least 2,050 litres capacity (See Annexure 2, Table 3, NSW Ministry of Health, 2016). For low pressure systems using a siphon or Flout, a smaller 500 litre or 1,000 litre dosing well is appropriate, as if the dosing device to fail, the system would automatically overflow to the trenches. The pump or siphon well can either be separate from the septic tank or a dedicated chamber in the septic tank (Figure 10.6). The pump and pump well, or dosing device and dosing well, should be designed to ensure that the trenches can be fully dosed for even distribution of the effluent. In all cases, the dose should be set at a minimum of 200 litres or three times the fill volume of the downstream pipe system, whichever is the greater.



Figure 10.3 Dosing siphon (Arris Wastewater Clinic)



Figure 10.4 Flout in dosing chamber



Figure 10.5 A submersible pump (Davey Pty Ltd)

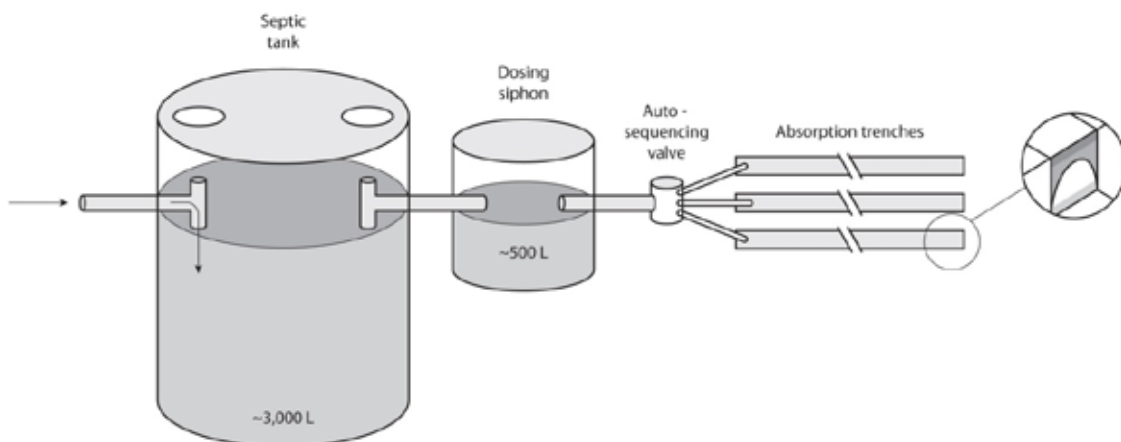

Figure 10.6 Septic tank, low pressure dosing device and trench set-up

- Trenches and beds must not be exposed to vehicle activity or grazing animals that can cause compaction and premature trench failure (Figure 10.7). Where vehicles and grazing animals can access the trench area, the owner must fence the area or plant a protective barrier of shrubs to prevent access.



**Figure 10.7 A failing trench due to vehicular activity**

Where a pump is used it should:

- be made from materials suitable for pumping septic tank effluent – it may be above ground or submersible
- have capacity to discharge the maximum daily flow against any physical or imposed head
- be able to be float switch controlled
- be statically mounted, protected from the elements and wired to operate automatically
- have all electrical work carried out according to the Supply Authority Service Rules and [AS/NZS 3000:2018 Electrical Installations \(known as the Australian/ New Zealand Wiring Rules\)](#)
- have all connection pipework made with approved material
- have an audible and visible alarm (the audible alarm should be mutable) in a highly visible place in the kitchen or laundry to warn of pump failure and high-water level.

A pump or siphon can be used together with a sequencing valve (Figure 10.2).

## 10.2 Installation

A number of installation techniques should be used to ensure effective long-term operation of an absorption trench or bed. Absorption trenches or beds often fail because of poor installation.

Follow the steps below when installing an absorption trench or bed.

### **Step 1 Site preparation**

Obtain a copy of the council approved plans and conditions of consent. Accurately locate the area for the construction of trenches and beds as shown on the site plans and according to the specified and approved design and/or any covenant. Check the location of all constructed trenches and beds against the approved site plans. If there is any change in their position from

the site plans, ask Council if a Modification of consent is required to alter their position. A change in location may require a new soil assessment.

### **Step 2**            *Positioning*

Build the trenches and beds along the contours and use laser levelling to ensure that the base is exactly level. If this does not happen, distribution will not be even and one part of the trench will be more heavily loaded. This could cause the most heavily loaded part of the trench to fail prematurely, with further creeping failure as the effluent is forced to more distant parts of the trench.

Always avoid cutting trenches through existing weakened ground (e.g. through the alignments of former underground pipes, cables or conduits) as they may provide preferential pathways for effluent to escape from the trench. If they cut downslope through the ground occupied by a series of trenches, effluent may preferentially flow to the lowest trench causing it to fail or surcharge. Where it is unavoidable to cut into an alignment or it happens accidentally, seal the weaknesses in the trench walls with cement or bentonite grout.

### **Step 3**            *Timing*

Build trenches during fine weather. If it rains before trenches are completed, they should be covered to protect them from rain damage.

Once dug, complete the trenches promptly to avoid foreign material being washed into the open trench (Figure 10.8). In particular, avoid puddling, where clay settles out at the bottom of a water filled trench exposed to rain, as clay settling on the base of the trench will reduce trench performance.



**Figure 10.8**            **Unfinished trench**

#### **Step 4**            **Excavation**

- Carefully excavate the base of any trench and level it with a dumpy or laser level. The trench must be level along and across the line of the trench. If there is a slope across the base of the trench, the effluent will drain to and preferentially load the downslope side of the trench, which may then fail or overflow.
- Where trenches are dug along the contour on sloping ground by an excavator that does not have a pivoting bucket, the base of the trench will probably be cut parallel to the ground surface. In this case, the base of the trench will have a fall towards the downslope side. The trench should be further hand dug to level the base and stop excessive effluent accumulating against the downslope wall of the trench.
- Where trenches are dug by excavator in clayey soils, any smearing of the trench walls and floor must be roughened by scarifying the surface.

#### **Step 5**            **Construction**

- Do not dig trenches in dispersive soils. If the soil appears dispersive after the trenches are dug, add gypsum to the trench base at the rate of one kilogram per square metre. Absorption trenches should not be built in medium to heavy clay soils, and preferably not in light clay soils; trenches should only be considered if the design complies with [AS/NZS1547:2012](#) (see Section 2).
- Install a self-supporting pipe or arch (ReIn) that complies with [AS/NZS1547:2012](#).
- Ensure that the sides of trenches are not damaged or caused to collapse when the trenches are filled with gravel or sand.
- Trenches can be filled with gravel (typically 20-40 millimetres or occasionally coarse sand), but it should not be compacted. Appropriate consideration should be given to trench storage capacity where trenches are filled with material other than gravel.
- Lay geotextile filter cloth over the gravel or sand in a trench and under the topsoil to ensure that the topsoil does not penetrate and block the trench.
- Test the trenches and beds with clean water before filling with gravel (or coarse sand) to ensure effective and even distribution of effluent.
- Apply 150 to 200 millimetres of topsoil to the top of the trench and leave it slightly mounded above ground level to allow it to settle and to encourage incident rainfall to be shed away from the top of the trench.
- The top of the absorption trench area should be turfed or grass planted to establish vegetation cover promptly after construction. This ensures the best uptake of effluent by evapotranspiration. Ensure that larger deep-rooting plants are not planted close to trenches to reduce the chance of root intrusion and clogging of the trenches.
- A stormwater diversion berm / drain should be built on sloping sites upslope of the absorption trenches or beds. Standard Drawing 1 (Appendix 4) provides detail about constructing a stormwater diversion drain.

#### **Step 6**            **Dosing**

- Trenches or beds may be gravity-fed or pressure-dosed using pumps or low pressure dosing devices. Raised pressure-dosed absorption beds are a possible alternative where there are shallow limiting layers present (e.g. bedrock, clay or water table) and not enough separation distance (Section 2) from that layer. An appropriate linear loading rate must be selected in these situations.
- The annotated Standard Drawing No. 10A describes the installation of gravity-fed trenches and beds. Annotated Standard Drawing No. 10B describes the installation of pressure-dosed trenches and beds. Annotated Standard Drawing No. 10C describes the installation of raised pressure-dosed absorption beds.

- Checklist 10.1 details matters that should be checked when trenches or beds are installed. Plumbers/installers and Council inspectors can use this checklist to ensure installation has been completed properly.

### 10.3 Testing

Test trenches and beds with clean water before filling with gravel (or coarse sand) to ensure even distribution. If pressure dosed, the trenches or beds should be pressure tested to ensure uniform squirt height at each orifice and to check that sequencing valves are operating properly.

### 10.4 Operation

The owner must regularly inspect trenches and beds, together with the septic tank. This detailed maintenance inspection should include:

- checking around the trench for signs of leakage
- checking the water level at any inspection ports in the trench to ensure it is not flooded
- checking that the low pressure dosing device or splitter box is working properly and not blocked or clogged
- checking that any pump is operating correctly. If the system includes a standby pump, it should be regularly alternated with the operating pump to ensure that the work hours on both are approximately equal
- checking the control system and ensuring that it is set to deliver appropriate volumes of effluent to specific irrigation fields according to the hydraulic design
- checking that the tank is regularly desludged to limit the amount of solids carried over into the trench. Section 3 of this Manual includes details about desludging a septic tank
- inspecting the septic tank outlet filter every three months and hosing the filter off where necessary, ideally into a bucket or directly into the inlet 'T' of the septic tank. Cleaning should only remove gross solids and not the biofilm that accumulates on filter surfaces.

The owner should also perform a number of general maintenance and operational tasks, including:

- ensuring all products used in the household are safe for the system (bleaches and many household cleaning products are not)
- managing vegetation around the trench / bed and tank (including mowing grass around the trench area for maximum exposure)
- ensuring a continuous power supply to the system where a pump well is installed. The power to the system should not be turned off when the house is unoccupied.
- Calling a plumber as soon as practicable if a pump well alarm activates.

Checklist 10.2 details items to be checked during a regular maintenance inspection for an absorption system.

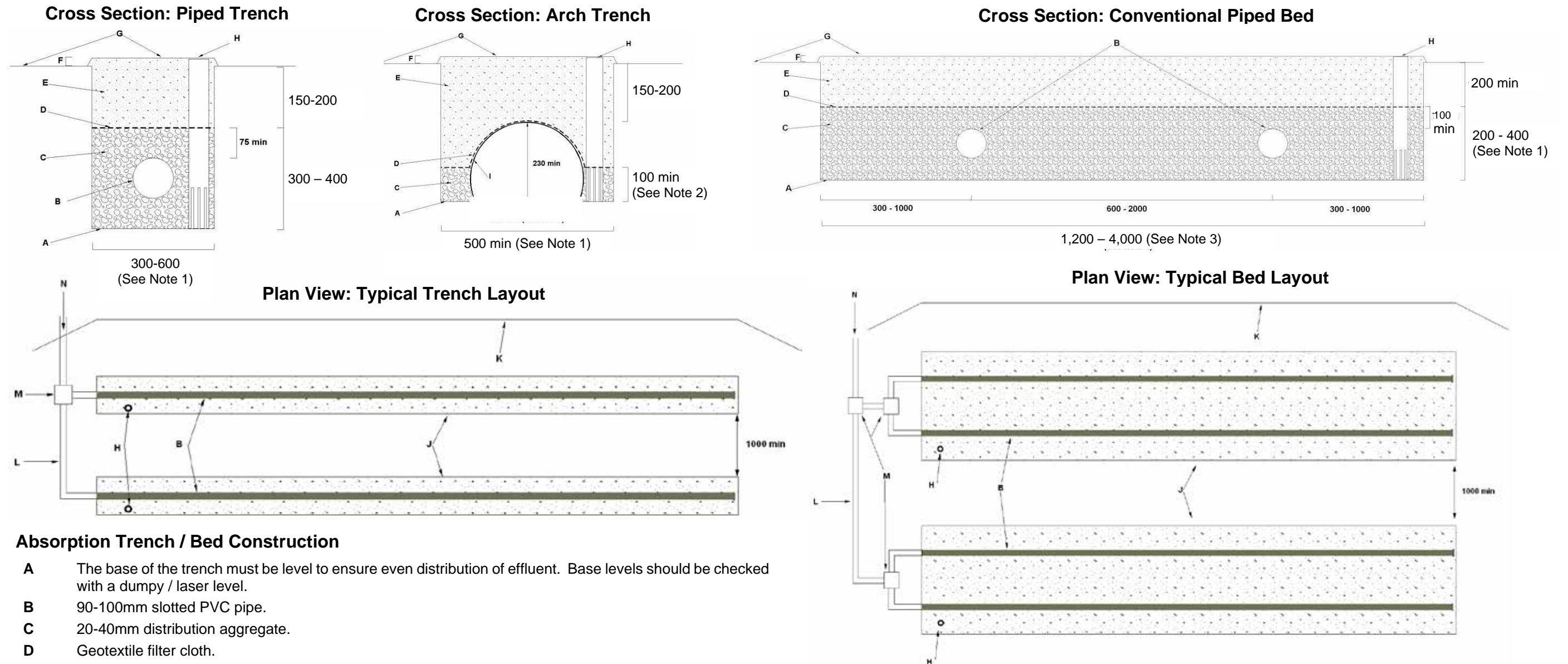

**Absorption Trench / Bed Construction**

- A** The base of the trench must be level to ensure even distribution of effluent. Base levels should be checked with a dumpy / laser level.
- B** 90-100mm slotted PVC pipe.
- C** 20-40mm distribution aggregate.
- D** Geotextile filter cloth.
- E** Clean local or imported topsoil (sandy loam to clay loam).
- F** Allowance for settling after backfilling.
- G** Grass must be established across the construction area as soon as possible. Trench / bed surface must be slightly mounded.
- H** Inspection port on downhill side of trench / bed. Made from 50mm PVC pipe with perforations in the aggregate level of the trench / bed.
- I** Self-supporting arch trench that complies with AS/NZS1547:2012.
- J** Trench / bed dimensions are an example only. The basal area of the effluent management area must be determined according to the procedures set out in AS/NZS1547:2012 and this document. The location and orientation of the area should be based on a site and soil assessment by a suitably qualified person. The system may comprise a single trench / bed or multiple smaller trenches / beds. It is essential that effluent is distributed evenly to all units on a daily basis.
- K** Upslope stormwater diversion drain (see Standard Drawing 1 for design detail). Subsoil drainage may be necessary on particular sites.
- L** 90-100mm PVC gravity dosing pipe.
- M** Gravity splitter box to distribute effluent evenly between two to four separate trenches / beds. Should also be used to evenly dose multiple pipework within a single trench / bed.
- N** Gravity or pump fed effluent from treatment system.

**Notes**

- 1** Trenches should be a maximum of 600mm (piped trench) or 1,000mm (arch trench) wide. Optimum width will balance storage requirements against footprint and required trench length.
- 2** 100mm of aggregate is the minimum depth. Depth can be increased to provide more storage if required, however, a minimum 150-200mm of topsoil must exist above the top of the arch trench material. Alternative proprietary void / support materials are available to provide a substitute for both aggregate and arch trench.
- 3** Consideration should be given to maintaining a level base when determining an appropriate width. Gravity-fed beds are generally not suitable for sites with highly permeable soils due to difficulties in maintaining even distribution. Primary-treated effluent should not be dosed; effluent should at least be secondary-treated. Pressure dosing should be used in such soils.
- 4.** WaterNSW notes that drilling holes within PVC pipe makes them non-compliant with the AS/NZS 3500, as it impacts the structural integrity of the pipe.

**Standard Drawing 10A – Absorption Trench / Bed**  
(not to scale)

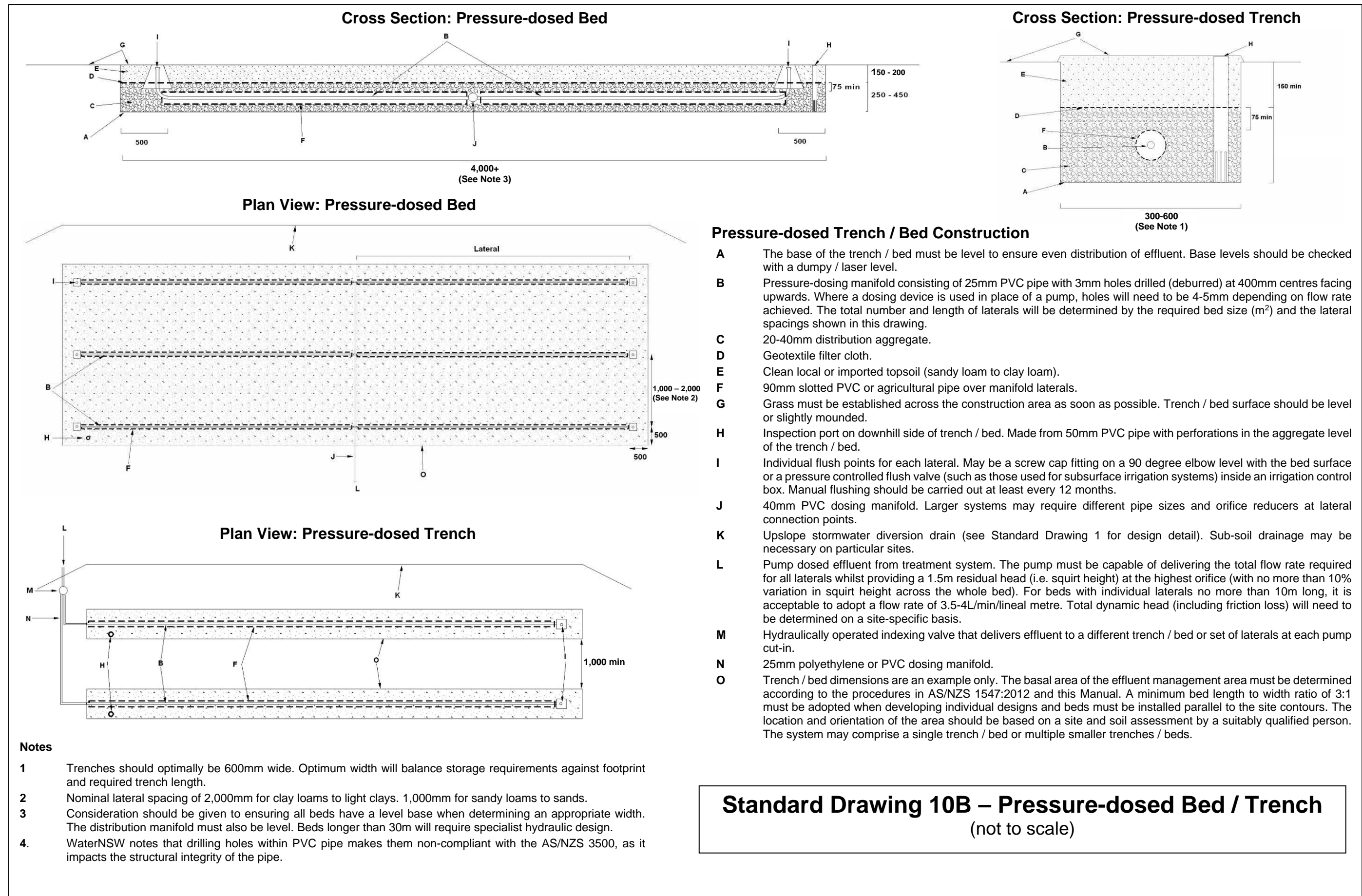

**Pressure-dosed Trench / Bed Construction**

- A** The base of the trench / bed must be level to ensure even distribution of effluent. Base levels should be checked with a dumpy / laser level.
- B** Pressure-dosing manifold consisting of 25mm PVC pipe with 3mm holes drilled (deburred) at 400mm centres facing upwards. Where a dosing device is used in place of a pump, holes will need to be 4-5mm depending on flow rate achieved. The total number and length of laterals will be determined by the required bed size (m<sup>2</sup>) and the lateral spacings shown in this drawing.
- C** 20-40mm distribution aggregate.
- D** Geotextile filter cloth.
- E** Clean local or imported topsoil (sandy loam to clay loam).
- F** 90mm slotted PVC or agricultural pipe over manifold laterals.
- G** Grass must be established across the construction area as soon as possible. Trench / bed surface should be level or slightly mounded.
- H** Inspection port on downhill side of trench / bed. Made from 50mm PVC pipe with perforations in the aggregate level of the trench / bed.
- I** Individual flush points for each lateral. May be a screw cap fitting on a 90 degree elbow level with the bed surface or a pressure controlled flush valve (such as those used for subsurface irrigation systems) inside an irrigation control box. Manual flushing should be carried out at least every 12 months.
- J** 40mm PVC dosing manifold. Larger systems may require different pipe sizes and orifice reducers at lateral connection points.
- K** Upslope stormwater diversion drain (see Standard Drawing 1 for design detail). Sub-soil drainage may be necessary on particular sites.
- L** Pump dosed effluent from treatment system. The pump must be capable of delivering the total flow rate required for all laterals whilst providing a 1.5m residual head (i.e. squirt height) at the highest orifice (with no more than 10% variation in squirt height across the whole bed). For beds with individual laterals no more than 10m long, it is acceptable to adopt a flow rate of 3.5-4L/min/lineal metre. Total dynamic head (including friction loss) will need to be determined on a site-specific basis.
- M** Hydraulically operated indexing valve that delivers effluent to a different trench / bed or set of laterals at each pump cut-in.
- N** 25mm polyethylene or PVC dosing manifold.
- O** Trench / bed dimensions are an example only. The basal area of the effluent management area must be determined according to the procedures in AS/NZS 1547:2012 and this Manual. A minimum bed length to width ratio of 3:1 must be adopted when developing individual designs and beds must be installed parallel to the site contours. The location and orientation of the area should be based on a site and soil assessment by a suitably qualified person. The system may comprise a single trench / bed or multiple smaller trenches / beds.

**Notes**

- 1 Trenches should optimally be 600mm wide. Optimum width will balance storage requirements against footprint and required trench length.
- 2 Nominal lateral spacing of 2,000mm for clay loams to light clays. 1,000mm for sandy loams to sands.
- 3 Consideration should be given to ensuring all beds have a level base when determining an appropriate width. The distribution manifold must also be level. Beds longer than 30m will require specialist hydraulic design.
4. WaterNSW notes that drilling holes within PVC pipe makes them non-compliant with the AS/NZS 3500, as it impacts the structural integrity of the pipe.

**Standard Drawing 10B – Pressure-dosed Bed / Trench**  
(not to scale)

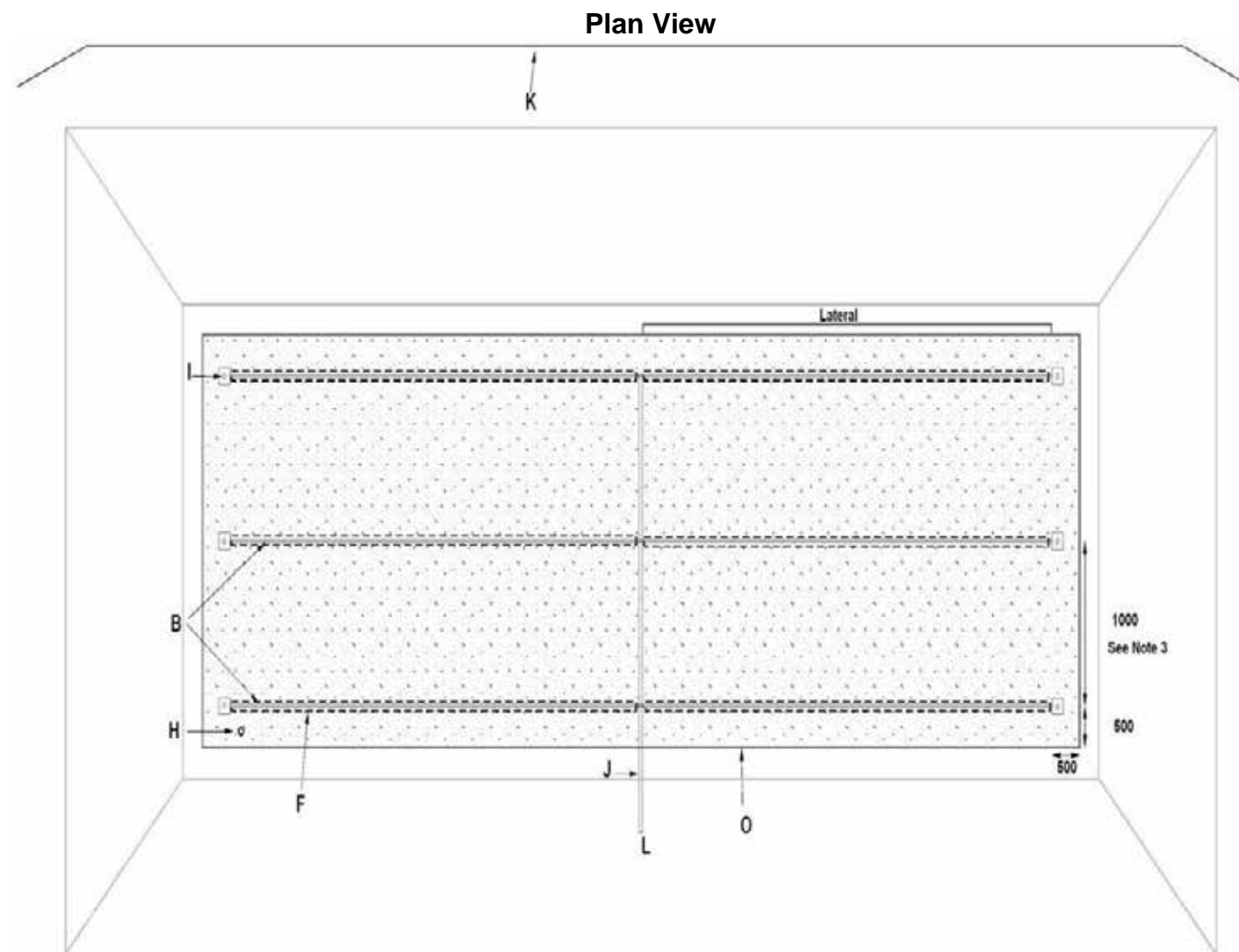
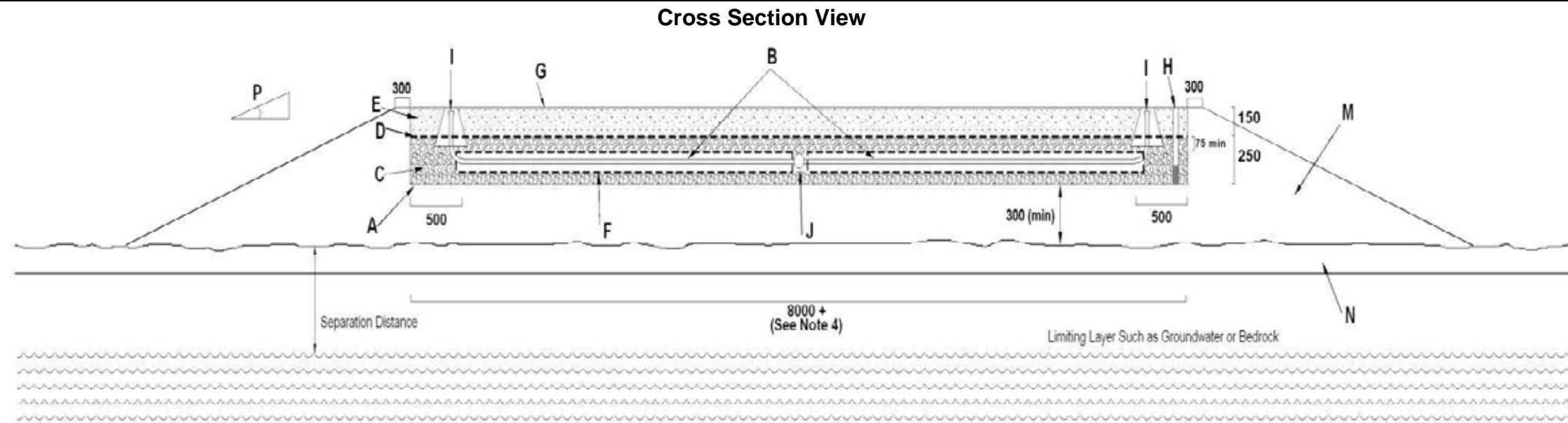

**Notes**

- 1 The layout and dimensions used in these drawings are for general guidance only. The location, configuration and layout of individual beds will need to be determined on a site-specific basis. The purpose of this drawing is to illustrate a typical configuration and specify minimum system components.
- 2 Consideration should be given to ensuring all beds have a level base when determining an appropriate width. The distribution manifold must also be level. Beds longer than 30m will require specialist hydraulic design.
- 3 WaterNSW notes that drilling holes within PVC pipe makes them non-compliant with the AS/NZS 3500, as it impacts the structural integrity of the pipe.

**Standard Drawing 10C –  
Raised Pressure Dosed Absorption Bed  
Construction**  
(not to scale)

**Standard Drawing 10C (cont.)****Raised Pressure-Dosed Absorption Bed Construction**

- A** The base of the trench must be level to ensure even distribution of effluent. Base levels should be checked with a dumpy / laser level.
- B** Pressurised dosing laterals consisting of 25mm PVC pipe with 3mm holes drilled (deburred) at 400mm centres facing upwards. The total number and length of laterals will be determined by the required bed size (m<sup>2</sup>) and the lateral spacings shown in this drawing. It is essential that effluent is distributed evenly across the distribution bed. A residual head (or squirt height) of 1.5m should be achieved across the distribution laterals. The squirt height across the laterals must be tested prior to covering with agricultural / slotted pipe, with no more than 10% variation in height observed. Consideration must also be given to static head and friction loss when sizing pumps. A full hydraulic design must be carried out.
- C** 20-40mm distribution aggregate.
- D** Geotextile filter cloth.
- E** Clean local or imported topsoil (sandy loam to loam).
- F** 90mm slotted PVC or agricultural pipe over manifold laterals.
- G** Grass must be established across the construction area as soon as possible. The bed surface should be slightly mounded.
- H** Inspection port on downhill side of trench / bed. Made from 50mm PVC pipe with perforations in the aggregate level of the trench / bed.
- I** Individual flush points for each lateral. May be a screw cap fitting on a 90 degree elbow level with the bed surface or a pressure controlled flush valve (such as those used for subsurface irrigation systems) inside an irrigation control box. Manual flushing should be carried out at least every twelve months.
- J** PVC or polyethylene dosing manifold. Larger systems may require different pipe sizes and orifice reducers at lateral connection points.
- K** Upslope stormwater diversion drain. Subsoil drainage may be necessary on particular sites.
- L** Pump dosed effluent from treatment system (minimum primary treatment with an outlet filter).
- M** The base of each absorption bed is to be raised to a height of 300mm above the final ground surface (total bed height 700mm). Compaction should be minimised when installing the bed. The fill must be a loam to sandy loam with minimal clay content.
- N** Prepare the site by clearing all shrubs, trees and boulders. Cut trees to ground level and then grind the stump out to a depth of 300mm and backfill with permeable material such as the natural topsoil or sand (definitely not clay). Scarify the natural soils across the entire basal area to a minimum depth of 200mm taking care not to compact the basal area in the process. This should extend to at least 1m beyond the perimeter.
- O** The bed dimensions shown are an example only. The basal area of the effluent management area must be determined based on the load and soil characteristics of the site. **A minimum bed length to width ratio of 3:1 must be adopted when developing individual designs and beds must be installed parallel to the site contours.** The location and orientation of the area should be based on a site by a suitably qualified person. The system may comprise a single bed or preferably multiple smaller beds.
- P** Batter slope 1(vertical):3(horizontal) maximum.

<b>Checklist 10.1 Installation of trenches and beds for use by plumbers / installers and Council inspectors</b>			
Site owner:			
Address:			
Installation date:			
Trench / bed coordinates:			
Type of system:			
Method of application: <input type="checkbox"/> Gravity <input type="checkbox"/> Pump <input type="checkbox"/> Siphon/Flout			
Configuration: <input type="checkbox"/> Trench <input type="checkbox"/> Absorption bed			
<b>Pre-construction considerations</b>			
Is the soil moisture too wet for construction? <input type="checkbox"/> Yes <input type="checkbox"/> No			
<b>Site preparation</b>			
Trench / bed area marked according to site plan / conditions of consent including buffer and setback distances <input type="checkbox"/> Yes <input type="checkbox"/> No			
Trenches / beds positioned according to design requirements for contours <input type="checkbox"/> Yes <input type="checkbox"/> No			
<b>Trench or bed dimensions</b>			
Number of trenches / beds			
Width:	mm	Length:	mm
Trench / bed dimensions consistent with council's consent		<input type="checkbox"/> Yes	<input type="checkbox"/> No
Confirm all system elevations		<input type="checkbox"/> Yes	<input type="checkbox"/> No
Stake trench / bed boundaries with elevations		<input type="checkbox"/> Yes	<input type="checkbox"/> No
Method of excavation:			
Trench / bed bottom graded to specifications		<input type="checkbox"/> Yes	<input type="checkbox"/> No
<b>Inspection ports</b>			
Type:	Diameter:      mm		
Perforations	<input type="checkbox"/> Slotted	<input type="checkbox"/> Drilled	
Grade <sup>(1)</sup> from tank to trench	<input type="checkbox"/> Above grade (a pump will be required)	<input type="checkbox"/> Below grade	
<b>Media</b>			
<input type="checkbox"/> Gravel <input type="checkbox"/> Sand <input type="checkbox"/> Other (specify):			
Media size and source:		Cleaned and graded	<input type="checkbox"/> Yes <input type="checkbox"/> No
Total media depth:	mm	Total amount of media used:	m <sup>3</sup>
<b>Distribution system</b>			
Gravity distribution device		<input type="checkbox"/> Yes	<input type="checkbox"/> No
Type:	<input type="checkbox"/> Splitter box	<input type="checkbox"/> Sequencing valve	<input type="checkbox"/> Drop box <input type="checkbox"/> Other (describe)



## 10.5 Inspection

Council should inspect all trenches and beds, and all associated pipe and drainage work before backfilling, to ensure all components are correctly positioned and installed according to the [ABCB National Construction Code \(NCC\) Series Volume Three – Plumbing Code of Australia](#) (Commonwealth of Australia, and the States and Territories of Australia 2022, published by the Australian Building Codes Board). Council should inspect the final installation to ensure it complies with all conditions of consent before issuing an approval to operate the system.

Plumbers, Council inspectors and system owners can use Checklist 10.2 to inspect an absorption system and check that it is operating properly.

## 10.6 Common technical issues

Plumbers, property owners and regulatory authorities have observed a number of common problems with absorption trench or bed installations, including:

- not installed as per the approved design and specification
- undersized trenches
- trenches that are connected in series
- trench/bed has an uneven base
- the side of the trench has been smeared with excavator bucket, reducing the hydraulic conductivity of the soil around the trench walls
- uneven distribution of effluent caused by gravity trickle feeding, which predominantly loads the upstream end of the trench or the first trench of a system of trenches
- trenches are constructed too long for even distribution of effluent
- trenches are constructed too short in shallow soils (linear loading rate)
- ineffective distribution boxes to split the flows evenly to trenches
- old trenches that have exceeded their operational life.

<b>Checklist 10.2 Operation of trenches and beds for use by plumbers, Council inspectors and system owners</b>	
Site owner:	
Address:	
Installation date:	
Trench / bed coordinates:	
Is there evidence of surface water or soggy ground on the trench / bed area (e.g. after emptying a bath)?	<input type="checkbox"/> Yes <input type="checkbox"/> No
Are some trenches or beds greener than others?	<input type="checkbox"/> Yes <input type="checkbox"/> No
Is there evidence of stormwater intrusion?	<input type="checkbox"/> Yes <input type="checkbox"/> No
Is there any indication that water on the surface of the trench or bed is effluent?	<input type="checkbox"/> Yes <input type="checkbox"/> No
Is there evidence of vehicle, human or animal traffic over the trench / bed area?	<input type="checkbox"/> Yes <input type="checkbox"/> No
Is there evidence of protective measures to prevent trench / bed damage (e.g. shrubs, fencing)?	<input type="checkbox"/> Yes <input type="checkbox"/> No
Is a good vegetation cover established over the trench / bed surface?	<input type="checkbox"/> Yes <input type="checkbox"/> No
Does the trench / bed have good exposure to wind and sun?	<input type="checkbox"/> Yes <input type="checkbox"/> No
Are the inspection port interiors clear (i.e. no standing water suggesting trench flooding) and in good condition?	<input type="checkbox"/> Yes <input type="checkbox"/> No
Is the dosing device or splitter box working properly and not blocked or clogged?	<input type="checkbox"/> Yes <input type="checkbox"/> No
Is any pump is operating correctly?	<input type="checkbox"/> Yes <input type="checkbox"/> No
Is the control system set correctly to deliver appropriate volumes of effluent to specific irrigation fields according to the hydraulic design?	<input type="checkbox"/> Yes <input type="checkbox"/> No
Is the tank regularly desludged?	<input type="checkbox"/> Yes <input type="checkbox"/> No
Has the septic tank outlet filter been cleaned by way of hosing the filter off?	<input type="checkbox"/> Yes <input type="checkbox"/> No
<b>Comments, action or repairs needed:</b> (Where a response in this checklist needs extra information or action, specify the action plan and/or the process to fix the problem, or specify an alternative that is being offered)	
Service provider:	
Title:	
Contact number:	
Name of inspector:	
Signature:	Date:

## 10.7 Case study

A septic tank and absorption trench were installed on a sloping site (Figure 10.9). The trench was located upslope of the tank. A pump was fitted to the un baffled septic tank to pump to the trench. Within months the trench began to overflow and the pump burnt out.

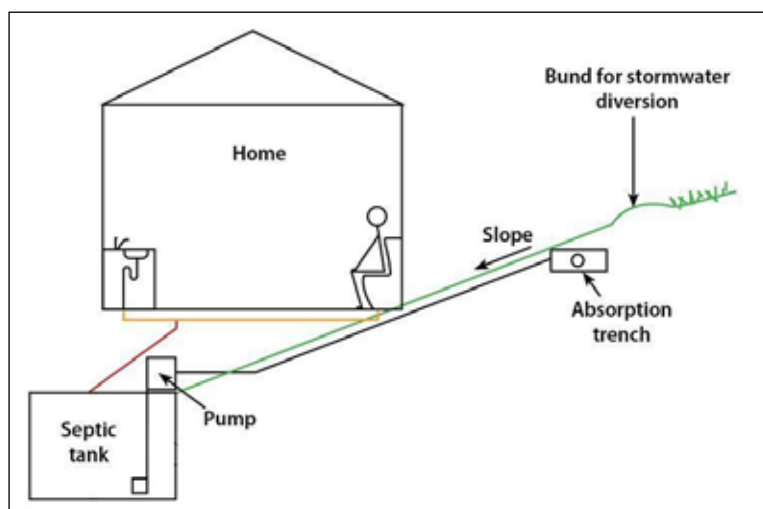

Figure 10.9 Septic tank and upslope trench – design problem

### Problem

The pump began to pump solids to the trench causing the trench to clog and overflow (Figures 10.10 and 10.11). The pump was working hard to pump solids to the trench that eventually caused a blockage and the pump to burn out.

### Solution

Install an outlet filter in the septic tank to improve effluent quality. Install a pump well (Figure 10.12) after the septic tank with a suitably sized pump to pump the clarified liquid to the absorption trench. This minimises the work required of the pump and reduces the amount of solids discharged to the trench, prolonging its life. Ideally a baffled tank should be installed.



Figure 10.10 Failing trench



Figure 10.11 Failing trench

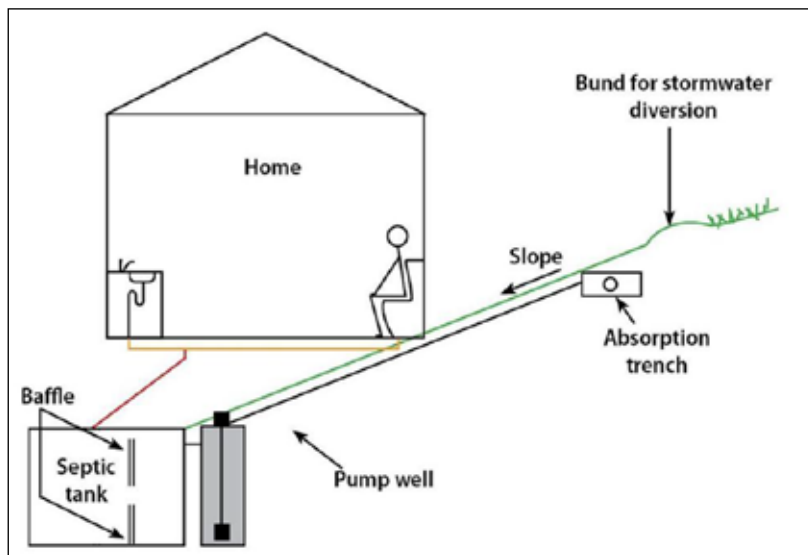

Figure 10.12 Septic tank and upslope trench – design solution

## 10.8 The 'Wick' trench and bed system

The Wick Trench and Bed effluent management system was developed by Kerry Flanagan of 'Kerry Flanagan Wastewater' for use in clay soils for primary and secondary effluent. The Wick System may also be used in other soil categories and on small lots (where applicable), as the system is designed to maximise the movement of effluent up through the soil to plant roots and the atmosphere<sup>4</sup>.

The Wick System is a series of trenches with adjacent evapo-transpiration (EVT) beds that are underlain and joined by a layer of geotextile. The EVT bed may be installed on either side of the trench. The surface of the combined trench and EVT bed, which is approximately three times the

<sup>4</sup> Geotextile cloth should fully wrap any trench or bed constructed in soils containing sand or fine gravel. The use of textiles also regulates the drop out rate in the highly permeable soils.

width of a conventional trench, is planted with herbaceous vegetation to maximise the wicking effect over the large surface area. The geotextile acts as the 'wick' to continuously draw liquid upwards through capillary action. Plant roots and leaves, the sun and the wind act as 'pumps' to draw the liquid upwards out of the soil and into the atmosphere.

### 10.8.1 'Wick' trench and bed system design

- NSW Health non-disinfected effluent to be disposed of at a soil depth of more than 300 millimetres for both trenches and beds (NSW Health, 2017).
- The Wick Trench and Bed System must be installed on flat land. Where the available land is not flat, it must be terraced to provide a flat platform.
- Avoid filling hollows across the contour as this may interfere with effluent distribution.
- The trench must have uniform depth to provide uniform performance along its length<sup>5</sup>.
- To prevent flooding of the septic tank, the surface level of the Wick Trench must be at least 150mm below the invert of the septic tank outlet (e.g. where the tank outlet invert is 400mm below the top of the tank, the ground level of the Wick Trench must be at least 550mm lower).
- On sites where it is not possible to have a 550mm height difference between the septic tank outlet invert and the Wick Trench, a suitably-sized distribution pump must be used.<sup>6</sup>

#### 'Wick' trench sizing

Typically the 'Wick' trench will be built with an evapotranspiration bed slightly less than twice the width of the trench. For example, a bed 1,000 millimetres wide with a 600 millimetre wide trench as shown in Figures 10.13a and 10.13b. The trench is built using an arch trench that is a plastic self-supporting arch 410 millimetres wide and 1,500 millimetres long.

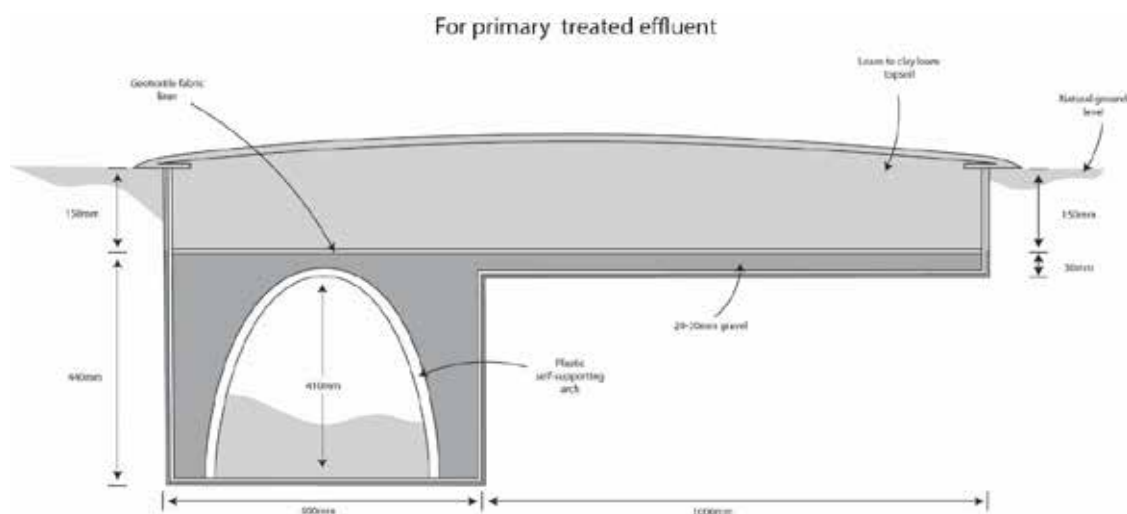
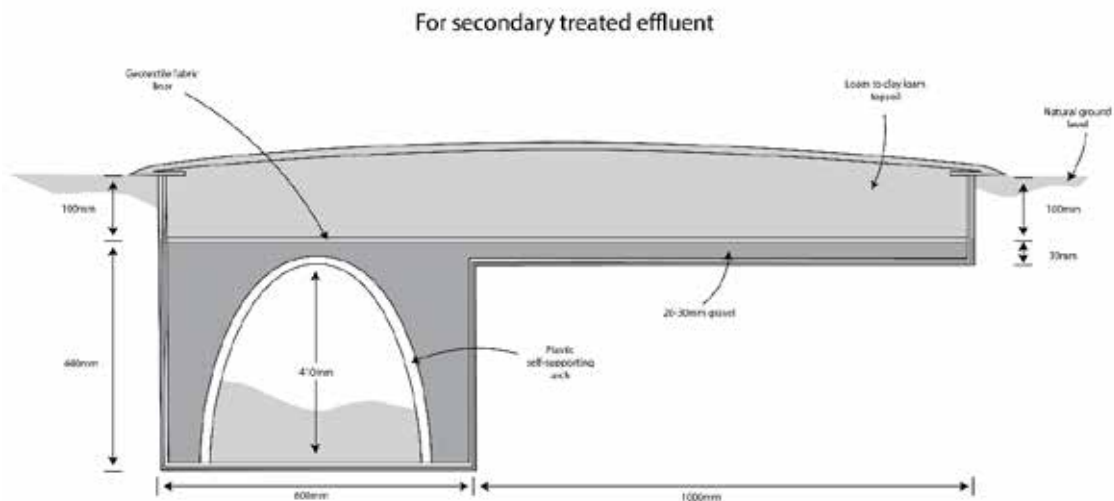

Figure 10.13a 'Wick' trench for primary treated effluent

<sup>5</sup> Trenches and beds must be constructed to provide an even depth of soil over the final level which should be level as well. This provides an even hydraulic resistance to the evapo-transpiration. The soil type should also be the same the full length of the trench.

<sup>6</sup> This also applies to all beds and trenches.



**Figure 10.13b 'Wick' trench for secondary treated effluent**

The required length of 'Wick' trench can be calculated using the daily design flow rate (L/day) and the design loading rates (DLR) for absorption trenches and evapotranspiration beds in [AS/NZS 1547:2012](#).

For a conservative design, the designer recommends using the formula:

$$L = Q / \text{DLR} \times (W/F)$$

Where:

- L = total length of 'Wick' trench/bed required in metres
- Q = design daily flow rate in litres a day
- DLR = design loading rate in mm per day
- F = factor of **1.2**<sup>7</sup>
- W = total width of trench and bed in the combined 'Wick' trench

### Example for Primary Treated Effluent

To size a 'Wick' trench system for a typical three-bedroom home on a Category 4 clay loam soil with tank water supply:

Design loading rate = 10 mm/m<sup>2</sup>/day for primary treated effluent

$$\begin{aligned} \text{Length of Trench / Bed} &= Q / [\text{DLR} \times (W/F)] \\ &= [(3 \text{ bedrooms} + 1) \times 200\text{L/day}] / [10\text{L/m}^2 \times 1.6 \text{ m} / 1.2] \\ &= 800\text{L} / [10\text{L/m}^2 \times 1.6\text{m} / 1.2] \\ &= 800\text{L} / 13.3\text{L/m} \\ &= 60\text{m} \end{aligned}$$

This would be built with three 20m long Wick Trench/Beds.

$$\begin{aligned} \text{Area of the Wick Trench and Bed System} &= (\text{Length} \times \text{Width}) \\ &= 60\text{m} \times (600\text{mm} + 1000\text{mm}) \\ &= 60\text{m} \times 1.6\text{m} \\ &= 96\text{m}^2 \text{ (plus spacing between the Trench/Bed units)} \end{aligned}$$

<sup>7</sup> The 1.2 correction factor applies to 1.6m wide Wick trenches made up of a 600 wide trench and a 1m bed. Additional uptake can be achieved by using beds on both sides; however, it is the responsibility of the designer to calculate the added uptake.

### Example for Secondary Treated Effluent

Length of Wick Trench System for a standard three bedroom house on clay loam soil:

Length of Trench / Bed =  $Q / [\text{DLR} \times (\text{WIF})]$

$$= [(3 \text{ bedrooms} + 1) \times 200\text{L/day}] / [30\text{L/m}^2 \times 1.6\text{m}/1.2]$$

$$= 800 \text{ L} / [30\text{L/m}^2 \times 1.6\text{m}/1.2]$$

$$= 800\text{L}/40\text{L/m}$$

$$= 20\text{m}$$

This would be built with one 20m long Wick Trench/Beds or two 10m long systems.

Area of the Wick Trench and Bed System = (Length x Width)

$$= 20\text{m} \times (600\text{mm} + 1000\text{mm})$$

$$= 20\text{m} \times 1.6\text{m}$$

$$= 32\text{m}^2 \text{ (plus spacing between the Trench/Bed units)}$$

#### 10.8.2 'Wick' trench and bed system Installation

1. Peg out the trench and pan areas to ensure an<sup>8</sup> even soil depth the full length of the trench.
2. Remove the topsoil and stockpile. Where this is a friable, loamy soil it can be reused as the final layer of the Wick Trench and Bed. Otherwise neither the topsoil nor lower soil horizons are to be reused in the system, and suitable loamy soil must be imported.
3. Excavate the trench to a depth of 600mm and the adjacent pan to 130mm for secondary effluent and 180mm for primary effluent systems (Figure 10.14).
4. Continuously check the level of the bed of the trench and the pan with a laser level to ensure they are flat (Figure 10.15).
5. Lay the 'A12 grade' geotextile fabric (with dry pore size 230-µm) in a continuous length across the trench and pan i.e. down the outer side wall of the trench, across the base of the trench, up the inner side wall of the trench, across the base of the pan and up the outer side wall of the pan (Figure 10.16).
6. Ensure the geotextile extends at least 50mm further than the top of the side walls.
7. Overlap the edges of the geotextile down the length of the trench and pan system until all bases and side walls are covered (Figure 10.17).
8. Place the plastic self-supporting arch in sections 410mm wide and 1500mm long, into the trench on top of the geotextile.

---

<sup>8</sup> It is a common mistake of installers of trenches and beds to not consider the natural ground levels before starting excavation. The plotted area should be level at either end and without dips or hollows.



**Figure 10.14 and 10.15**      **Excavation of the bed of the “Wick” trench**

9. Install inspection ports at trench entry points and the connection points to other trenches.
10. Install a mica-flap or plastic air admittance vent at the end of the each trench to facilitate air being drawn into the trench, up the pipe line into the septic tank, through the pipe line into the house drainage system and up through the roof vent. The mica- flap acts as a marker for the end of the trench. This does apply for pump fed trenches.



**Figure 10.16 and 10.17**      **Laying the liner in the trench and then the geotextile fabric as the ‘wick’ across the pan**

11. Spread clean 20-30mm gravel over the arch in the trench and across the pan to a depth of 30mm. Ensure the top of the gravel layer is level (Figure 10.18).
12. Lay overlapping lengths of geotextile across the top of the gravel layer, ensuring the geotextile extends at least 50mm further than the side walls of the trench and pan (Figure 10.19).
13. Spread good quality friable and permeable loamy soil over the top of the geotextile to a depth of 100mm for secondary effluent and 150mm for primary effluent systems. Never use soil from lower soil horizons. Local authority soil depths should be considered on primary fed trenches.



**Figures 10.18 Backfilling gravel layer**



**Figure 10.19 Adding the second geotextile fabric layer**

14. Slightly mound the surface of the topsoil across the trench and bed to help shed rainwater off the system (see Figure 10.20).
15. Plant the topsoil with a suitable grass or plants that thrive when their roots are continuously wet, especially those with large leaves as they will transpire more water than plants with small leaves.
16. Install stormwater diversion drains to direct stormwater away from the Wick System.



**Figure 10.20 Backfilling and the inspection ports**

### 10.8.3 Maintenance

The septic tank must be periodically desludged to ensure proper functioning of the Wick Trench and Bed System. It is recommended a root inhibitor is used on secondary effluent fed Wick trench and Bed system if large trees are with 30m of<sup>9</sup> the area.

<sup>9</sup> The use of trenches and bed with secondary effluent has shown that the root inhibiting provided by anaerobic primary effluent from large root intrusion does not occur. The oxygen rich effluent from a secondary treatment system requires that a root inhibitor should be used.

## 11 Evapotranspiration Absorption Beds

An evapotranspiration absorption (ETA) bed maximises loss of water by evapotranspiration, whilst reducing the reliance on absorption. ETA beds are often used where site limitations prevent the use of irrigation (lack of space) or absorption trenches (presence of clayey soils). An ETA bed is usually used to dispose of wastewater from a septic tank, but it can also be used to manage secondary treated effluent. Where fed by secondary effluent, root inhibitor should be used to reduce the risk of root ingress into the bed.

ETA beds are generally unlined beds with some deep seepage. Capillary action draws effluent up through the sand in the upper part of the ETA bed from the storage in the void spaces in the gravel bed beneath. This supplies the root zone of the vegetation (usually grass) on the top of the bed to optimise evapotranspiration. Effluent is distributed through the bed by a system of slotted pipes, or alternatively drilled pipes if the system is pressure dosed.

Vegetation cover must be well maintained to ensure strong growth for maximum uptake by transpiration. The surrounding landscape and vegetation must also be maintained to minimise shading and maximise exposure.

Figure 11.1 shows an ETA bed, with Figure 11.2 and Standard Drawing No.11A depicting cross sectional views.



Figure 11.1 An evapotranspiration absorption bed

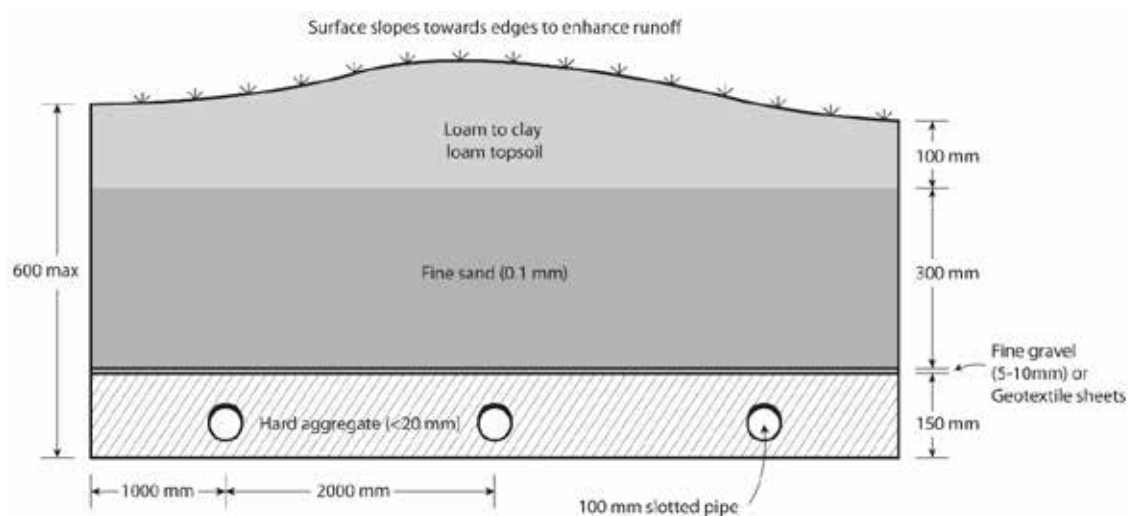

Figure 11.2 Cross section of an ETA bed (unlined) (after Patterson, 2006)

## 11.1 Design

The ETA bed should be designed with consideration for the site and soil assessment detailed in Section 2 of this Manual. The ETA bed should be sized according to the recommendations in [AS/NZS 1547:2012 On-site domestic wastewater management](#). Council approval is required to install an ETA bed under the *Local Government Act 1993* and it must comply with WaterNSW and Council requirements for buffer distances and setbacks from significant site features. Additional helpful information on design can be found in Patterson (2006). The following points should also be considered.

- All ETA beds should be designed using hydraulic balance modelling. This will ensure the optimum bed size and contain construction costs.
- The hydraulic balance determines the volume of storage in the gravel bed. This ensures the bed does not overtop in prolonged wet periods when evapotranspiration losses are lower than inputs from rainfall and effluent load.
- No dead ends be allowed in designs and both ends should be terminated at ground level for flushing and clearing.
- To prevent backflow into the septic tank if the trench floods, the ground surface level of the trench or bed must be at least 150mm below the invert of the septic tank outlet.
- Entry to a trench or bed should be by way of a 100mm DWV tee entering the top of trench and fed at the side. The top finished with a Bolted Tap Screw (BTS) to enable inspection of the flow and the trench.
- Beds and trenches fed by secondary effluent should be monitored for root intrusion and the fitment of a root inhibitor emitter or annual treatment should be considered.
- The bed must be turfed immediately following construction.
- ETA beds are constructed with a domed upper surface to shed rainfall. The steeper the slope the more rainfall that will be shed.
- The bed must be located where it will be well exposed to ensure maximum evapotranspiration.

## 11.2 Installation

A number of installation techniques should be used for effective long-term operation of an ETA bed. Common failures of ETA beds are often caused by poor installation practices. Follow the steps below when installing an ETA bed.

### **Step 1**                    **Site preparation**

- Obtain a copy of the Council approved plans and conditions of consent. Locate the area of beds accurately as shown on the site plans and according to the specified and approved design and/or any covenant. If there is any change in the site plans, ask Council if a Modification of consent is required.

### **Step 2**                    **Positioning**

- Beds must be built along the contours to ensure even distribution and avoid any one part of the bed being more heavily loaded. Failure to do this could lead to premature failure of the most heavily loaded part of the bed, followed by creeping failure as the effluent is forced to more distant parts of the bed.
- Avoid cutting beds through existing weakened ground (e.g. through the alignments of former underground pipes, cables or conduits) as they may provide preferential pathways for effluent to escape from the bed. If these pathways cut downslope through the ground occupied by a series of beds, effluent may preferentially flow to the lowest bed causing it to fail or surcharge. Where the bed must be cut into an alignment or it is done accidentally, seal any weaknesses in the trench walls with cement or bentonite grout.

### **Step 3**            **Timing**

- Beds should be built in fine weather. If rain does fall before the beds are completed, cover the beds to protect them from rain damage.
- Once dug, beds must be completed promptly to avoid foreign material being washed into the open excavation. Puddling (where clay settles at the bottom of a water filled bed left exposed to rain) must be avoided, as the clay on the base of the bed will reduce its performance.

### **Step 4**            **Excavation**

- The base of any bed should be carefully excavated and levelled with a dumpy or laser level. The bed must be level both along and across the line of the bed. Effluent will drain down any slope across the base of the bed and preferentially load the downslope side of the bed, which may then fail or surcharge.
- Where beds are dug along the contour on sloping ground, and by an excavator that does not have a pivoting bucket, the base of the bed will probably be cut parallel to the ground surface. In this case, the base of the bed will have a fall towards the down-slope side. The bed should be further hand dug to ensure a level base, and to prevent effluent accumulating against the downslope wall of the bed.
- Where beds are dug by an excavator in more clayey soils, scarify the bed walls to remove any smearing caused by the excavator bucket.

### **Step 5**            **Construction**

- Do not use ETA beds if the soil is dispersive. However, if a degree of dispersiveness is identified after the trenches are dug, add gypsum to the trench base at the rate of one kilogram a square metre. WaterNSW considers ETA beds may be suitable for medium to heavy clay soils, with appropriate design modifications.
- Ensure that the sides of beds are not damaged or caused to collapse when the beds are filled.
- Lay geotextile on top of the gravel media in a bed and beneath the sand to ensure that the sand does not penetrate and block the gravel media.
- Test piping with clean water before filling with gravel or sand to ensure that effluent is evenly and effectively distributed.
- Apply 150 millimetres of topsoil to the top of the bed and leave it mounded above the completed bed to allow for settlement and encourage rainfall to run off.
- Turf the top of the bed promptly after construction to ensure the best uptake of effluent by evapotranspiration. Ensure that deep rooting trees or shrubs are not planted close to the beds to reduce the chance of roots intruding and clogging the beds.
- Build a stormwater diversion berm/drain on sloping sites to avoid stormwater filling the ETA bed. Standard Drawing 1 (Appendix 4) provides detail about building a stormwater diversion drain.

### **Step 6**            **Dosing**

- ETA beds may be gravity-fed or pressure-dosed using pumps or dosing devices. Where there are shallow soil limiting layers present (e.g. bedrock or water table), and there is not enough separation distance (Section 2) from such layers, raised pressure-dosed ETA beds are a possible alternative. In these situations, the linear loading rate must also be addressed.
- The annotated Standard Drawing No. 11A describes the installation of evapotranspiration absorption beds. Checklist 11.1 provides guidance on aspects of an evapotranspiration absorption system that should be checked by the installer and regulator.

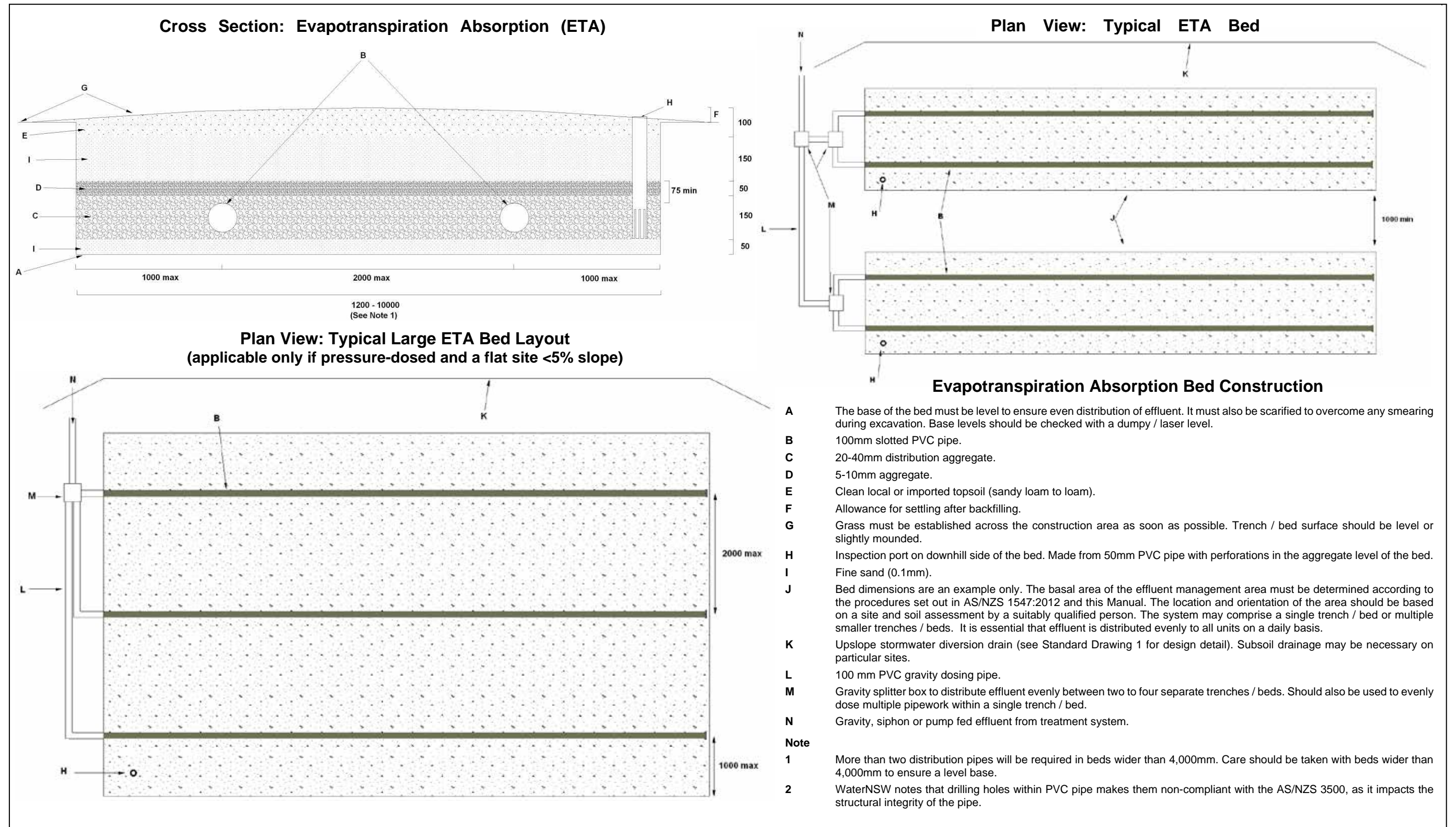

**Standard Drawing 11A – Evapotranspiration Absorption Bed**  
(not to scale)

**Checklist 11.1 Installation of ETA beds for use by plumbers / installers and Council inspectors**

Owner name:					
Address:					
Installation date:					
ETA bed coordinates:					
<b>System</b>					
Type of system:					
Method of application		<input type="checkbox"/> Gravity	<input type="checkbox"/> Pump	<input type="checkbox"/> Siphon	
Configuration		<input type="checkbox"/> Trench	<input type="checkbox"/> Absorption bed		
<b>Pre-construction considerations</b>					
Is the soil moisture too wet for construction?				<input type="checkbox"/> Yes	<input type="checkbox"/> No
<b>Site preparation</b>					
Bed area marked according to site plan / conditions of consent including buffer and setback distances				<input type="checkbox"/> Yes	<input type="checkbox"/> No
Bed is positioned according to design requirements for contours				<input type="checkbox"/> Yes	<input type="checkbox"/> No
<b>Bed dimensions</b>					
Number of beds:					
Width:		mm	Length:		mm
Depth:				mm	
Bed dimensions are consistent with council's consent				<input type="checkbox"/> Yes	<input type="checkbox"/> No
Confirm all system elevations				<input type="checkbox"/> Yes	<input type="checkbox"/> No
Stake bed boundaries with elevations				<input type="checkbox"/> Yes	<input type="checkbox"/> No
Method of excavation:					
Bed bottom graded to specifications				<input type="checkbox"/> Yes	<input type="checkbox"/> No
<b>Inspection ports</b>					
Type:			Diameter: mm		
Perforations:		<input type="checkbox"/> Slotted	<input type="checkbox"/> Drilled		
Grade <sup>(1)</sup> from tank to trench		<input type="checkbox"/> Above grade (a pump will be needed)		<input type="checkbox"/> Below grade	
<b>Media</b>					
Coarse aggregate specifications and source:			Fine aggregate specifications and source:		
Gravel type:			Aggregate type:		
Depth:			Depth:		
Cleaned and graded	<input type="checkbox"/> Yes	<input type="checkbox"/> No	Cleaned and graded	<input type="checkbox"/> Yes	<input type="checkbox"/> No
Total media depth:			mm	Amount of media used:	
				m <sup>3</sup>	

Checklist 11.1 continued					
Distribution system					
Distribution device:					
<input type="checkbox"/> Gravity			<input type="checkbox"/> Pressure		
Type: <input type="checkbox"/> Splitter box <input type="checkbox"/> Drop box (for serial distribution)			Type: <input type="checkbox"/> Pump <input type="checkbox"/> Siphon/Flout		
Description of header:			Valve type:		
Installation level:			<input type="checkbox"/> Alternating / sequencing		<input type="checkbox"/> Globe
Type of stable bedding material used:			<input type="checkbox"/> Gate ball		<input type="checkbox"/> Other
Manual valve (describe):					
Access					
<input type="checkbox"/> Riser	<input type="checkbox"/> In valve box in the field	<input type="checkbox"/> In bedding material	<input type="checkbox"/> In dosing tank	<input type="checkbox"/> Other (give details):	<input type="checkbox"/> None
Pressure manifold		Specification:			
Lateral feed configuration:					
<input type="checkbox"/> End	<input type="checkbox"/> Top	<input type="checkbox"/> Centre	<input type="checkbox"/> Bottom	<input type="checkbox"/> Other (give details):	
Type					
Diameter:		mm	Length:		mm
Orifice specifications / spacing / size / orientation (describe):					
Access / protection:			<input type="checkbox"/> Yes	<input type="checkbox"/> No	Describe:
Laterals					
Specification:			Type:		
Diameter:		mm	Spacing:		mm
			Length:		mm
Installation					
Geotextile/fabric cover placed over gravel				<input type="checkbox"/> Yes	<input type="checkbox"/> No
Final topsoil cover					
Depth of topsoil cover:			mm		
Imported material used				<input type="checkbox"/> Yes	<input type="checkbox"/> No
Nature of material (describe; should be clay loam-sandy loam):					
Stormwater diversion berm/drain constructed				<input type="checkbox"/> Yes	<input type="checkbox"/> No
Turf planted:					
Nature of protection of ETA beds (describe):					

**Checklist 11.1 continued**

**Comments, action or repairs needed:** (Where a response in this checklist needs extra information or action, specify the action plan and/or the process to fix the problem, or specify an alternative that is being offered)

**Service provider:**

**Title:**

**Contact number:**

**Name of inspector:**

**Signature:**

**Date:**

### 11.3 Testing

Test ETA beds with clean water before placing any media to ensure even distribution. If pressure-dosed, pressure test the piping to ensure uniform squirt height at each orifice and that any sequencing valve is working (Figure 11.2).

### 11.4 Operation

The owner should inspect the bed regularly. This detailed maintenance inspection should include:

- checking any pumps or dosing devices are working correctly. If the system includes a standby pump, it should be alternated with the working pump regularly to ensure that the work hours on both are approximately equal
- checking any splitter or dropdown boxes are working effectively, and/or Manual valves are switched between beds
- inspecting the control system and ensuring that it is set to deliver appropriate volumes of effluent to specific irrigation fields according to the design hydraulics
- checking around the bed for signs of leakage
- checking the water level in any inspection ports to ensure the bed is not flooded. Beds are designed to hold water for evapotranspiration, but if the bed becomes flooded the turf covering will die off.

#### General maintenance

The system owner must complete a number of general maintenance and operational tasks, including:

- addressing maintenance issues identified by the service provider
- ensuring all products used in the household are safe for the system (bleaches and many household cleaning products are not safe)
- ensuring the tank is regularly desludged to limit the amount of solids carried over into the bed. Section 3 of this Manual contains details on desludging a septic tank
- inspecting and cleaning the outlet filter of any septic tank every three months
- managing vegetation around the tank and bed (including mowing and trimming back bushes for maximum exposure)
- ensuring the system has a continuous power supply. The system power should not be turned off when the house is unoccupied
- ensuring a plumber is contacted as soon as practicable if an alarm activates.

### 11.5 Inspection

The ETA bed and all associated pipe and drainage work should be inspected by a Council inspector before backfilling, to ensure all components are correctly positioned and installed according to the [ABCB National Construction Code \(NCC\) Series Volume Three – Plumbing Code of Australia](#) (Commonwealth of Australia, and the States and Territories of Australia 2022, published by the Australian Building Codes Board). Council should make a final installation inspection to ensure compliance with all conditions of consent before issuing an approval to operate the system.

Checklist 11.2 can be used by plumbers, council inspectors and system owners to inspect operating ETA beds.

## 11.6 Common technical issues

Plumbers, property owners and regulatory authorities have observed a number of common problems with ETA bed installations including:

- not installed as per the approved design and specification
- inadequate hydraulic design resulting in undersized beds
- uneven distribution on flat sites, commonly caused by gravity feeding through a slotted pipe where most effluent escapes from the first few slots and is not evenly distributed throughout the bed. This can be fixed by pressure dosing through a smaller aperture drilled pipe
- inadequate 'in-bed' storage that causes surface saturation and surcharging
- beds that are built too large in surface area to sustain the surface vegetation in dry weather
- beds that are built too short along the contour (linear loading rate)
- inadequate exposure to wind, or shading by shrubs and trees lowering the rate of evapotranspiration
- accumulated salts due to a lack of deep seepage that is needed to ensure salts are periodically flushed from the system.

<b>Checklist 11.2 Operation of ETA beds for use by plumbers, Council inspectors and system owners</b>	
Owner name:	
Address:	
Installation date:	
ETA bed coordinates:	
Is there evidence of surface water or soggy ground on the trench / bed area (e.g. after emptying a bath)? <input type="checkbox"/> Yes <input type="checkbox"/> No	
Are some areas of the ETA bed(s) greener than others? <input type="checkbox"/> Yes <input type="checkbox"/> No	
Is there evidence of stormwater intrusion? <input type="checkbox"/> Yes <input type="checkbox"/> No	
Is there any indication that water on the surface of the trench or bed is effluent? <input type="checkbox"/> Yes <input type="checkbox"/> No	
Is there an indication of poor drainage on or near the bed area? <input type="checkbox"/> Yes <input type="checkbox"/> No	
Is there evidence of vehicle, human or animal traffic over the trench / bed area? <input type="checkbox"/> Yes <input type="checkbox"/> No	
Is there evidence of protective measures to prevent trench / bed damage (e.g. shrubs, fencing)? <input type="checkbox"/> Yes <input type="checkbox"/> No	
Is a good vegetation cover established over the trench / bed surface? <input type="checkbox"/> Yes <input type="checkbox"/> No	
Does the trench / bed have good exposure to wind and sun? <input type="checkbox"/> Yes <input type="checkbox"/> No	
Are the inspection port interiors clear (i.e. no standing water suggesting trench flooding) and in good condition? <input type="checkbox"/> Yes <input type="checkbox"/> No	
Is the dosing siphon or splitter box working properly and not blocked or clogged? <input type="checkbox"/> Yes <input type="checkbox"/> No	
Is any pump or siphon operating correctly? <input type="checkbox"/> Yes <input type="checkbox"/> No	
Is the control system set correctly to deliver appropriate volumes of effluent to specific irrigation fields according to the hydraulic design? <input type="checkbox"/> Yes <input type="checkbox"/> No	
Are regular desludges of the tank undertaken? <input type="checkbox"/> Yes <input type="checkbox"/> No	
Has the septic tank outlet filter been cleaned by way of hosing the filter off? <input type="checkbox"/> Yes <input type="checkbox"/> No	
<b>Comments, action or repairs needed:</b> (Where a response in this checklist needs extra information or action, specify the action plan and/or the process to fix the problem, or specify an alternative that is being offered)	
<b>Service provider:</b>	
<b>Title:</b>	
<b>Contact number:</b>	
<b>Name of inspector:</b>	
<b>Signature:</b>	<b>Date:</b>

## 11.7 Case study

An ETA bed was installed on a flat site with limited available area for on-site wastewater management. A few months later the bed began to show signs of surface seepage at one end.

### Problem

The bed was not pressure-dosed by pump or low pressure dosing device. All effluent was seeping out of the first few holes in the distribution laterals and not reaching the other end of the bed. The soil at the upstream end of the bed became saturated and could not accommodate the daily wastewater load from the house. The other end of the bed was not receiving any effluent.

### Solution

A pump well was installed to pump or siphon the clarified effluent to the ETA bed. The pump was hydraulically sized taking into account the head needed from the pump well to the bed, pressure loss in the pipes and the desired flow pressure needed from the laterals to evenly distribute effluent throughout the bed. Once pressurised, the ETA bed was restored to operation and it continues to work well. Figure 11.3 shows the testing for squirt height from the distribution laterals to ensure even distribution of effluent.



Figure 11.3 Pressure testing the distribution laterals for even distribution of effluent  
(Source: D Stafford)

## 12 Surface Irrigation

Surface irrigation (Figure 12.1) of secondary treated and disinfected effluent is permitted in NSW. However, surface irrigation has limitations because it increases the chance of human contact with the effluent. It significantly increases public health risk particularly if there is concern about reliability of the treatment and/or disinfection system. The most common disinfection process, chlorination, does not kill all pathogens. Surface saturation and runoff of effluent are also more likely with surface irrigation.

When considering installing irrigation system for effluent management via surface irrigation, a number of factors must be examined on a case-by-case basis, including:

- whether the site is high risk due to high slope, shallow soil or unsuitable soil type
- whether the site is subject to severe frosts
- proximity of any neighbours
- proximity of the proposed irrigation area to the dwelling
- annual average rainfall (should be less than 1,200 millimetres)
- slope of the effluent irrigation area (should be less than 10% (5.7 degrees)).



**Figure 12.1** A surface irrigation sprinkler (CET, 2019)

A wide variety of surface irrigation systems are available including rotary, impact, spray nozzle and dripper systems. Spray heads can be a fixed riser or pop-up sprinkler. WaterNSW does not permit the use of moveable sprinklers. Sprays must not generate aerosols and must have a throw and plume height that is suitable for the site. This will vary depending on proximity to buildings, recreation areas and other sensitive environments. Owners must also consider the logistics of maintenance and mowing grass.

## 12.1 Design

A surface irrigation system should be designed considering the site and soil assessments outlined in Section 2 of this Manual. An irrigation system should be sized according to Appendix 6 of the 'Onsite Wastewater Management Guidelines' (OLG, 2025) and using the design irrigation rate data for the soil from Table M1 of ['AS/NZS 1547:2012 On-site domestic wastewater management'](#) for hydraulic balancing, the 'Onsite Wastewater Management Guidelines' (OLG, 2025) to determine the dedicated nutrient uptake area for nutrient balancing, and WaterNSW's requirements.

Installing a surface irrigation system requires council approval under the *Local Government Act 1993*, and must comply with the 'Onsite Wastewater Management Guidelines' (OLG, 2025), and WaterNSW and council requirements for buffer distances from significant site features. The following points must also be considered.

- Carefully size the effluent irrigation area(s) and dedicated nutrient uptake areas using water and nutrient balances to determine the minimum area needed. The dedicated nutrient uptake area is the difference in area between the nutrient balance area (the larger of the nitrogen or phosphorus balance) and hydraulic balance area. This approach will help ensure that the vegetation is maintained, at least on the area required to satisfy the hydraulic balance and reduce the likelihood of vegetation die-off over the whole area in extended dry periods.
- All irrigation systems require careful hydraulic design to ensure appropriate equipment selection, satisfactory operation and even distribution.
- Protect the effluent irrigation area from potential run-on water by building an upslope diversion drain. Standard Drawing 1 (Appendix 4) shows the construction of a diversion drain.
- It is critical to choose an appropriate pump to adequately service the demands of the designated effluent irrigation areas. It must be able to overcome friction and head losses in the system and meet the required head and irrigation flow rates of the chosen irrigation sprays, sprinklers or emitters at the most distant point in the system. The effluent irrigation area may need to be divided into two or more fields supplied via a distribution or sequencing valve. Fields should be less than 400 square metres.
- Surface irrigation must use fixed sprinkler points with quick-coupling valves or similar. Rotate sprinklers throughout the effluent irrigation area.
- Typical heavy droplet rotary sprinklers with a design throw radius of two metres and a height of 400 millimetres are designed to maintain a flow rate of 0.05 litres per second at an operating pressure of 80-100kPa.
- The system must be designed to deliver an appropriate dosing volume that fully charges the irrigation lines in each field.
- Program irrigation to ensure even delivery of effluent to the fields in the effluent irrigation area.
- Carefully choose and specify the irrigation system components needed to ensure satisfactory operation. The standard irrigation kit supplied with an aerated wastewater treatment system is often inadequate. Matching the components of an irrigation system is a critical part of design.
- Lateral and sprinkler spacing should be at least five metres.
- The system must incorporate adequate filtration. Install a disc filter or a 100-150 micron filter before the sequencing valve. The filter must be cleaned at least every three months.
- Bury the effluent distribution line from the aerated wastewater treatment system to the effluent irrigation area at least 300 millimetres underground in a manner that prevents

damage or deformation. Where vehicles pass over the effluent distribution line, it should be buried at 500 millimetres (see Table 2.8).

- The laterals in the effluent irrigation field should be buried 100 to 150 millimetres underground.
- The system specifications must be clearly conveyed to the system installer. The system should be installed by a licensed contractor who should also complete and sign the Installation Certificate. Council should inspect the installed system to ensure it meets the design specifications.
- The aerated wastewater treatment system or other secondary treatment system must be serviced regularly to provide adequate treatment and ensure that the irrigation system does not become clogged with suspended solids or organic material.
- The system should use demand dosing, particularly where the load generated varies over time. Most aerated wastewater treatment systems dose load the effluent irrigation area. An adequately sized pump well will need to be incorporated in the system. Standard Drawing No.12A shows a demand dosed pump well.
- Incorporate air valves, pressure reducing valves and non-return valves into the design as required.
- The system must have the capacity to enable flushing to remove any suspended solids and organic growth that accumulate. Effluent should be flushed back to the treatment system or to a soakage pit in the irrigation field. Ensure that chlorinated effluent is not returned to the primary chamber of the treatment system as chlorine can adversely affect the biological treatment processes. Most aerated wastewater treatment systems use chlorine for disinfection.
- Where the effluent irrigation area is located above the treatment system or pump well, fit a non-return valve.
- Surface effluent irrigation area slopes should be less than 10% (5.7 degrees).
- Adequately vegetate effluent irrigation areas with suitable grass species before commissioning the irrigation system.
- Install adequate signs to indicate that the area is being irrigated with treated effluent.
- Where vehicles, animals or children could access the effluent irrigation area, protect the effluent irrigation area by fencing or planting suitable shrubs around the outside edge.
- Mow the effluent irrigation area to ensure maximum evapotranspiration and removal of nutrients. Dispose of clippings outside the effluent irrigation area.

### **Hydraulic design**

A suitably qualified consultant must prepare a hydraulic design for the effluent irrigation area. The hydraulic design is essential to ensure the irrigation system will work appropriately and distribute the effluent evenly.

## 12.2 Installation

A number of installation techniques should be used for effective long-term operation of a surface effluent irrigation area. Common failures of irrigation systems are often caused by poor installation practices and using inappropriate system components. The irrigation system must be installed by a licensed contractor. Follow the steps below when installing a surface irrigation system.

### **Step 1 Site preparation**

Obtain a copy of the council approved plans and conditions of consent. Accurately locate the irrigation areas as specified in the conditions of consent and shown on the site plans, and according to the specified and approved design and/or any covenant. If there is any variation in their position from the site plans, ask Council if a consent modification application must be made under section 4.55 of the *Environmental Planning and Assessment Act 1979*.

### **Step 2 Positioning**

Build the laterals of an irrigation system along the contours to avoid uneven distribution and more heavily loading part of the irrigation area, which can lead to premature failure of the effluent irrigation area.

### **Step 3 Excavation**

Bury irrigation lines and distribution laterals at least 100 millimetres below natural ground level to protect them from UV damage and lawn mowers. These lines can be installed using a small trench digger.

### **Step 4 Construction**

The irrigation distribution mains and laterals can be installed and sprinkler heads attached to the lines. Before backfilling, flush and check the lines for leaks or breaks.

The effluent irrigation area should be turfed or planted with grass to establish vegetation cover promptly after construction. This ensures the best uptake of effluent by evapotranspiration. Ensure that deep rooting trees and shrubs are not planted close to irrigation lines to reduce the chance of roots intruding and clogging the laterals.

Build a stormwater diversion berm / drain on sloping sites to prevent stormwater inundation of the effluent irrigation area. Standard Drawing 1 (Appendix 4) provides detail on building a stormwater diversion drain.

### **Step 5 Dosing**

Pressure dose irrigation systems to provide even distribution throughout the entire area. Standard Drawing No.12A shows a demand dose pump well. Annotated Standard Drawing No. 12B describes the installation of a surface effluent irrigation area.

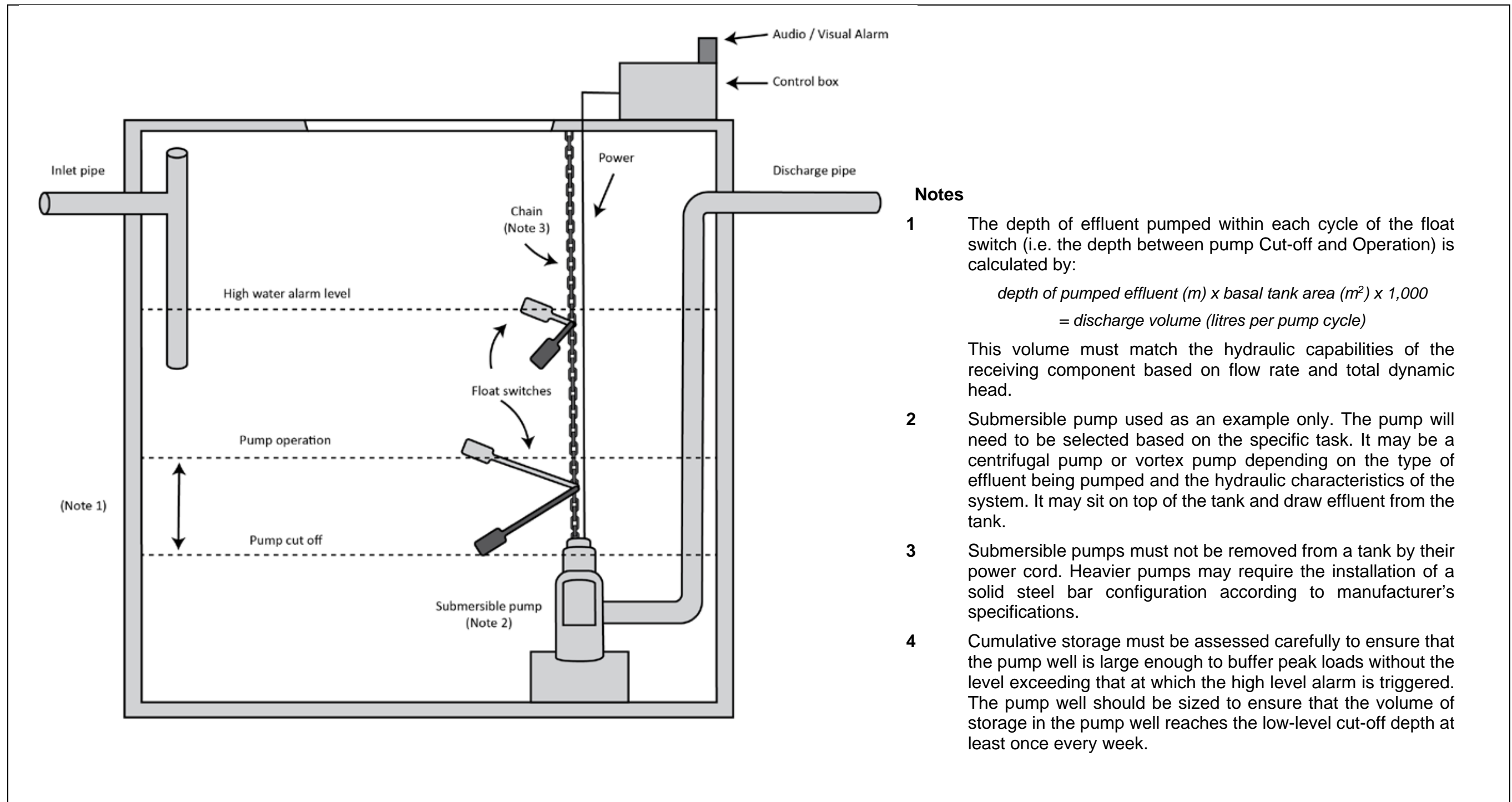

**Notes**

- 1 The depth of effluent pumped within each cycle of the float switch (i.e. the depth between pump Cut-off and Operation) is calculated by:  

$$\text{depth of pumped effluent (m)} \times \text{basal tank area (m}^2\text{)} \times 1,000$$

$$= \text{discharge volume (litres per pump cycle)}$$

This volume must match the hydraulic capabilities of the receiving component based on flow rate and total dynamic head.
- 2 Submersible pump used as an example only. The pump will need to be selected based on the specific task. It may be a centrifugal pump or vortex pump depending on the type of effluent being pumped and the hydraulic characteristics of the system. It may sit on top of the tank and draw effluent from the tank.
- 3 Submersible pumps must not be removed from a tank by their power cord. Heavier pumps may require the installation of a solid steel bar configuration according to manufacturer's specifications.
- 4 Cumulative storage must be assessed carefully to ensure that the pump well is large enough to buffer peak loads without the level exceeding that at which the high level alarm is triggered. The pump well should be sized to ensure that the volume of storage in the pump well reaches the low-level cut-off depth at least once every week.

**Standard Drawing 12A – Demand Dose Pump well**  
(not to scale)

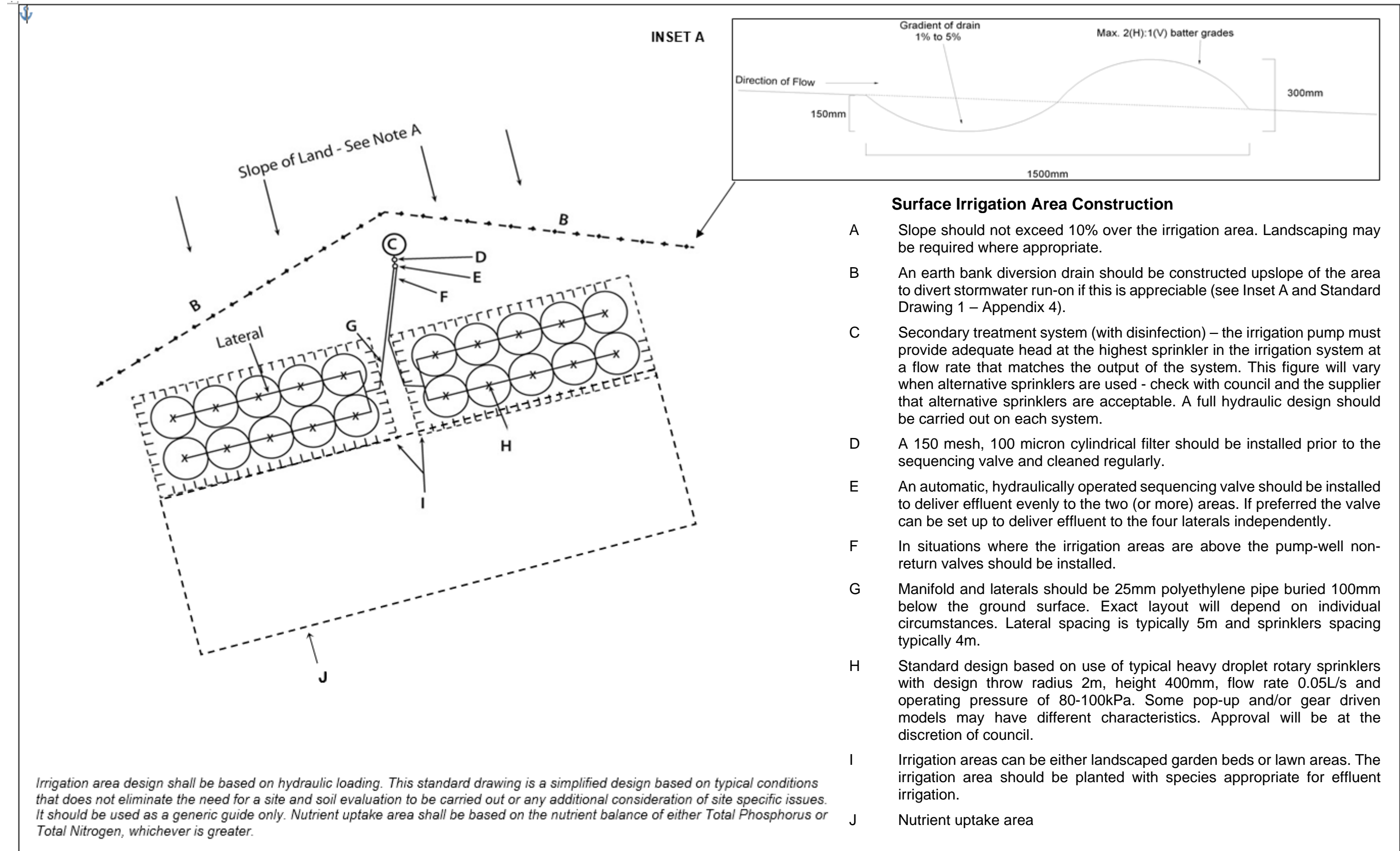

### Standard Drawing 12B – Surface Irrigation of Effluent

(not to scale)

### 12.3 Testing

Surface irrigation systems should be clean water / pressure tested before commissioning to ensure even distribution of effluent and a uniform squirt height (Figure 12.2) at each sprinkler location and to ensure that sequencing valves are working.



Figure 12.2 Testing squirt height of a surface irrigation system

### 12.4 Inspection

The irrigation system must be inspected by Council before backfilling, to ensure all components are installed according to the [ABCB National Construction Code \(NCC\) Series Volume Three – Plumbing Code of Australia](#) (Commonwealth of Australia, and the States and Territories of Australia 2022, published by the Australian Building Codes Board) and the conditions of consent. Council must make a final installation inspection to ensure compliance with all conditions of consent, before issuing an approval to operate the system.

Council inspectors can use Checklist 12.1 for the final installation inspection of a newly installed operational surface irrigation system.

Service and maintain all effluent irrigation areas at least every three months, except those systems specifically accredited with a four-month maintenance period. The aerated wastewater treatment system (or other secondary treatment system) should be serviced and maintained at the same time and included in the written report submitted to council. Checklist 12.2 can be used to inspect working surface irrigation systems (as well as the standard quarterly inspection by the service provider). Plumbers, council inspectors and the system owner can use the checklist to ensure the irrigation system is operating properly, and also for council compliance inspections.

Checklist 12.1 Installation of surface irrigation system for use by plumbers, installers and Council inspectors		
Site Owner:		
Address:		
Installation date:		
Irrigation area coordinates:		
Is the effluent irrigation area located according to the conditions of consent and the wastewater report or any covenant?	<input type="checkbox"/> Yes	<input type="checkbox"/> No
Is the size of the effluent irrigation area consistent with the conditions of consent and the wastewater report?	<input type="checkbox"/> Yes	<input type="checkbox"/> No
<b>Is the effluent irrigation area located according to buffer distances<sup>(1)</sup> relating to:</b>		
Dwelling and other buildings?	<input type="checkbox"/> Yes	<input type="checkbox"/> No
Swimming pool and other sensitive receptors?	<input type="checkbox"/> Yes	<input type="checkbox"/> No
Driveways and property boundaries?	<input type="checkbox"/> Yes	<input type="checkbox"/> No
Drainage features?	<input type="checkbox"/> Yes	<input type="checkbox"/> No
Are appropriate authorised fittings used as part of the system?	<input type="checkbox"/> Yes	<input type="checkbox"/> No
Fixed sprinkler type:	<input type="checkbox"/> Bayonet <input type="checkbox"/> Pop-up <input type="checkbox"/> Other (describe):	
Sprinkler head type (describe):		
What is the sprinkler plume height? <sup>(2)</sup>		mm
What is the sprinkler throw? <sup>(2)</sup>		m
Are the sprinklers appropriately spaced given their throw and plume height?	<input type="checkbox"/> Yes	<input type="checkbox"/> No
Do the sprinklers receive uniform amounts of effluent?	<input type="checkbox"/> Yes	<input type="checkbox"/> No
Have Manual or automatic sequencing valves been installed?	<input type="checkbox"/> Yes	<input type="checkbox"/> No
Has a disc filter been installed upstream of any sequencing valve?	<input type="checkbox"/> Yes	<input type="checkbox"/> No
Have air, pressure-reducing and/or non-return valves been incorporated into the design (as needed)?	<input type="checkbox"/> Yes	<input type="checkbox"/> No
Does the irrigation system have a flushing valve?	<input type="checkbox"/> Yes	<input type="checkbox"/> No
Does the flushing line return to the wastewater treatment system (not the primary chamber)?	<input type="checkbox"/> Yes	<input type="checkbox"/> No
Is the flushing line directed to a small absorption pit?	<input type="checkbox"/> Yes	<input type="checkbox"/> No
Has the pump sufficient capacity to service the demands of the effluent irrigation area and overcome friction and head losses in the system?	<input type="checkbox"/> Yes	<input type="checkbox"/> No
Is the effluent distribution line from the tank to the effluent irrigation area buried at an appropriate depth (minimum 300mm) and in a manner that provides protection against mechanical damage or deformation? <sup>(3)</sup>	<input type="checkbox"/> Yes	<input type="checkbox"/> No
Are the distribution laterals buried at a depth of between 100-150mm?	<input type="checkbox"/> Yes	<input type="checkbox"/> No
Has the effluent irrigation area been turfed?	<input type="checkbox"/> Yes	<input type="checkbox"/> No
Has the irrigation area been protected to prevent damage (e.g. using fencing)?	<input type="checkbox"/> Yes	<input type="checkbox"/> No

Checklist 12.1 continued	
Is remedial action needed? <span style="float: right;"><input type="checkbox"/> Yes   <input type="checkbox"/> No</span>	
<b>Note:</b> some of the questions in the above checklist may not be relevant for either the initial installation inspection or ongoing operational inspections. In this case, answer N/A.	
<b>Comments, action or repairs needed:</b> (Where a response in this checklist needs extra information or action, specify the action plan and/or the process to fix the problem, or specify an alternative that is being offered)	
<b>Service provider:</b>  <b>Title:</b>  <b>Contact number:</b>	
<b>Name of inspector:</b>	
<b>Signature:</b>	<b>Date:</b>

<sup>(1)</sup> See Table 2.6

<sup>(2)</sup> AS/NZS 1547:2012 On-site domestic wastewater management

<sup>(3)</sup> See Table 2.8

Checklist 12.2 Operation inspection <sup>(1)</sup> of effluent management area for use by service agents, Council inspectors and system owners		
Site Owner:		
Address:		
Installation date:		
Effluent management area coordinates:		
Does the system owner have a set of plans of the irrigation system and an Operational and Maintenance Manual? <input type="checkbox"/> Yes <input type="checkbox"/> No		
Effluent Management Area		
Is there any evidence of physical damage?	<input type="checkbox"/> Yes <input type="checkbox"/> No	Comment:
Is surface ponding evident or is there evidence of runoff from the effluent irrigation area?	<input type="checkbox"/> Yes <input type="checkbox"/> No	Comment:
Is there evidence of diversion of effluent outside the irrigation area?	<input type="checkbox"/> Yes <input type="checkbox"/> No	Comment:
Is there uneven or excess weed growth in the irrigation area?	<input type="checkbox"/> Yes <input type="checkbox"/> No	Comment:
Are there dry areas or areas lacking vegetation in the irrigation area?	<input type="checkbox"/> Yes <input type="checkbox"/> No	Comment:
Is any stormwater run-on effectively diverted around the irrigation area?	<input type="checkbox"/> Yes <input type="checkbox"/> No	
Has the effluent irrigation area been mown to maintain the grass short, particularly around the pop-up sprinkler heads or bayonet points?	<input type="checkbox"/> Yes <input type="checkbox"/> No	
Are all the sprinkler heads working appropriately?	<input type="checkbox"/> Yes <input type="checkbox"/> No	
If not, have the sprinkler heads been replaced or repaired with approved sprinkler heads?	<input type="checkbox"/> Yes <input type="checkbox"/> No	
Is the irrigation pump working?	<input type="checkbox"/> Yes <input type="checkbox"/> No	
If an automatic sequencing valve is fitted, does it switch between the different fields sequentially?	<input type="checkbox"/> Yes <input type="checkbox"/> No	
If a Manual valve is fitted, has it been switched between the different fields?	<input type="checkbox"/> Yes <input type="checkbox"/> No	
Have any bayonet sprinkler heads been moved to different parts of the irrigation area?	<input type="checkbox"/> Yes <input type="checkbox"/> No	
Has the irrigation filter been checked and cleaned?	<input type="checkbox"/> Yes <input type="checkbox"/> No	
Are all irrigation lines working (i.e. all sections of the effluent irrigation area work without leaking)?	<input type="checkbox"/> Yes <input type="checkbox"/> No	
<b>Note: if as a system owner, you answered 'No' to any of the above questions, or there are any other problems, you should contact your service provider immediately.</b>		
Does the system require air bleeding?	<input type="checkbox"/> Yes <input type="checkbox"/> No	
Is the irrigation area adequately protected from livestock, vehicles, children etc. through the use of fencing, or shrub barriers etc.	<input type="checkbox"/> Yes <input type="checkbox"/> No	

**Checklist 12.2 continued**

Is there any inappropriate use of the irrigation area e.g. vegetable growing?  Yes  No

**Comments, action or repairs needed:** (Where a response in this checklist needs extra information or action, specify the action plan and/or the process to fix the problem, or specify an alternative that is being offered)

**Service provider:**

**Title:**

**Contact number:**

**Name of inspector:**

**Signature:**

**Date:**

<sup>(1)</sup>In addition to the standard quarterly inspection by the service provider.

## 12.5 Operation

A surface irrigation system requires additional operational maintenance which is usually the responsibility of system owners. Operational maintenance includes:

- regularly mowing the effluent irrigation area and disposing of the grass clippings outside of the effluent irrigation area
- ensuring all sprinklers are working. Contact the service agent immediately if there are any problems with sprinklers or blockages
- clean the filters installed on some irrigation systems regularly. System owners are responsible for regularly cleaning these filters
- where Manual switching valves are installed, switch them as indicated
- fit moving bayonet sprinkler heads.

Property owners can use Checklist 12.2 to ensure regular maintenance on their system is carried out.

## 12.6 Common technical issues

Plumbers, regulatory authorities and property owners have observed a number of common technical problems with surface irrigation, including:

- not installed as per the approved design and specification
- using irrigation components that are not designed for use with wastewater effluent
- inadequate hydraulic design causing uneven effluent distribution
- effluent irrigation area too small causing hydraulic overloading and saturation
- owners supplementing irrigation during high rainfall events using freshwater to establish or maintain vegetation that needs more water to survive. This can cause surface runoff, ponding or saturation
- irrigation fields too large so that the hydraulic load does not reach the more distant ends of the irrigation lines and overloads the nearer ends. Effluent irrigation areas should be zoned so that each field is of a size that can be adequately serviced by the pump, with fields irrigated using an automatic sequencing valve
- pumps poorly matched to the demands of the irrigation system. Where large irrigation areas are located upslope of the treatment system, the capacity of many pumps supplied with proprietary aerated wastewater treatment systems can be exceeded. Typically, each sprinkler has a design operating pressure (4 to 20 metres) and flow rate (2 to 10 litres per minute). If the pump is too small, flow distribution will not be equal.
- insufficient irrigation lines and sprinklers are installed to adequately distribute effluent over the required effluent irrigation area
- irrigation lines are exposed and not buried underground, causing potential problems such as UV deterioration, frost damage, lawn mower damage, vehicle and animal access, children playing and dog chewing
- reliance on the homeowner to move lines to ensure even distribution of effluent
- appropriate buffer distances are not observed
- over-spray onto paved surfaces causing localised runoff
- sprinklers spray outside the designated effluent irrigation area onto other sensitive receptors such as buildings, stormwater drains, children's play areas, barbecues, washing lines and pools
- irrigation lines are moved to the garden beds for lawn mowing and not moved back

- irrigation lines are coiled on top of the aerated wastewater treatment system for lawn maintenance and not moved back. This can cause overloading or flooding of the system or electrical hazards
- irrigation lines are moved to garden beds and over-irrigate a small area or spray onto, over or through garden fences and hedges and onto adjoining property
- irrigation onto sites that are too steeply sloping causing surface runoff
- sprays generate aerosols which can be caused by the pump being too large
- water hammer in the irrigation lines which can be caused by the pump being too large
- pop-up sprays become overgrown and do not pop up causing concentrated irrigation around the spray head instead of over the larger effluent irrigation area
- sprinkler heads become overgrown and can't be moved
- irrigation lines become blocked due to inadequate treatment or filtration of effluent
- effluent irrigation area not maintained, and grass not mowed
- effluent irrigation area inappropriately used to grow vegetables or fruit for consumption
- owner neglect.

## 12.7 Case study

A new aerated wastewater treatment system was installed. The supplier included the tank, its internal components and a 30 metre poly hose with four standard garden sprinklers. The hose was left coiled on top of the tank after the system was commissioned and the sprinklers were not fitted (Figure 12.3). The owner decided to leave the sprinklers off and just move the hose around the yard to irrigate the gardens. The treated effluent drained freely from the irrigation pipe into the yard and, if left, it would saturate the soil and run down into the stormwater drainage line.

### Problems identified

- The owner did not know the council, WaterNSW or NSW Health requirements.
- The owner did not have a copy of the approval conditions and did not know how the effluent irrigation area should have been installed.
- The system supplier did not provide the relevant fittings and components that the owner needed to comply with the approval.
- The 30 metre hose, even with the four sprinklers, did not evenly distribute the treated effluent over the allocated area.
- The pump in the irrigation well was not big enough to evenly distribute effluent.
- The system was never inspected by council.
- The owner had not been well informed by the installer of the aerated wastewater treatment system about operating and maintaining the system.

### Solution

- Discard the supplied pipe and sprinklers.
- Install a number of fixed distribution lines (suitable for burial) with sprinklers that comply with council's approval to evenly distribute effluent across the allocated area.
- Place pop-up sprinklers at one every 12 square metres to ensure even sprinkler coverage.
- Install a sequencing valve to ensure effluent is evenly irrigated throughout each field.



Figure 12.3 A surface irrigation system left coiled on top of treatment tank

## 13 Subsurface and Subsoil Irrigation

Subsurface irrigation (Figures 13.1, 13.2 and 13.3) reduces the chance of human contact with the effluent and significantly reduces public health risk. By placing the effluent in the root zone of plants, beneficial reuse of both the hydraulic and nutrient components of the effluent is maximised, offering enhanced environmental benefits. Homeowners have less maintenance obligations when a subsurface irrigation system is installed. There are also potential amenity benefits offered by subsurface irrigation, such as less chance of surface saturation and effluent runoff.

NSW Health requires non-disinfected effluent, such as that from septic tanks and most wet composting treatment systems, to be disposed of at least 300 millimetres underground i.e. **subsoil** (as opposed to **subsurface**). **Subsoil** irrigation puts effluent largely below the depth of the root zone of most grasses. This means there is limited nutrient uptake and it is unlikely to result in a healthy growing lawn. However, it does minimise the risk of human contact with untreated effluent and minimises surface runoff during extended wet weather. Subsoil irrigation also creates an easy-to-maintain effluent irrigation area. Supplementary disinfection units cannot be added to a treatment system unless they are already part of a NSW Health approved system. Wastewater management using trenches is often a more attractive option as it provides a much smaller footprint system.

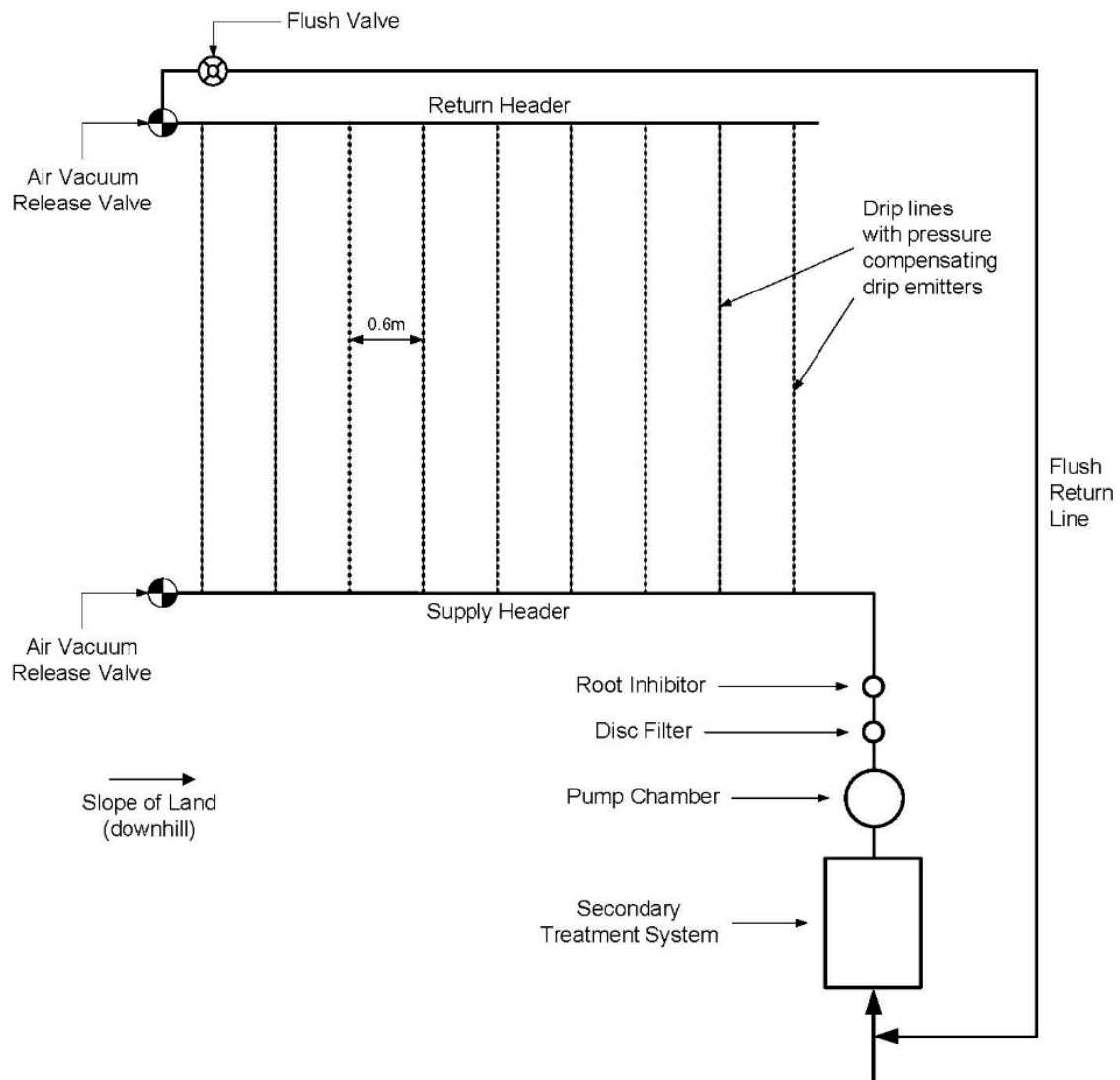

**Figure 13.1**  
**A subsurface irrigation system under construction**  
**(Warrnambool City Council)**



**Figure 13.2**  
**An installed subsurface irrigation system with close emitter spacing**  
**(Whitehead & Associates)**

There have been significant developments in subsurface drip technology for effluent irrigation in the domestic market. Subsurface irrigation involves pressure-dosing of a polyethylene pipe fitted with turbulent flow or, preferably, pressure compensating drip emitters. Proprietary systems may have built-in protection against root intrusion and biofilm development. Pressure compensation / regulation ensures even distribution of effluent and low application rates across a variety of gradients and elevations.



**Figure 13.3 Subsurface irrigation schematic for effective distribution and flushing**  
 (Source: Centre for Environmental Training, 2019)

Subsurface irrigation of disinfected effluent puts the effluent directly in the root zone to optimise hydraulic and nutrient take-up. It minimises the risk of human contact and reduces surface runoff during extended wet weather. Subsurface irrigation allows better amenity and easier maintenance of an effluent irrigation area.

Careful hydraulic design of subsurface irrigation is essential to ensure correct sizing and choice of components, including providing for adequate effluent pumping, effluent filtration, line flushing, placement of vacuum release valves, and correct spacing of laterals and emitters. Consideration of rainfall is as important for sizing subsurface irrigation areas as for surface irrigation, however subsurface irrigation may allow for higher nutrient uptake in the same location.

## 13.1 Design

A subsurface irrigation system should be designed with consideration for the site and soil assessment outlined in Section 2 of this Manual. The irrigation system should be sized according to the recommendations in the 'Onsite Wastewater Management Guidelines' (OLG, 2025) and WaterNSW requirements. Installing a subsurface irrigation system requires council approval under the *Local Government Act 1993*. It must also comply with WaterNSW and council requirements for buffer distances and setbacks from significant site features and infrastructure.

The following factors should be considered when designing a subsurface irrigation system:

- All effluent irrigation areas require appropriate sizing based on hydraulic loading and shall include a dedicated nutrient uptake area downslope or around the EMA depending upon the topography of the site. The dedicated nutrient uptake area is the difference in area between the nutrient balance area (the larger of the nitrogen or phosphorus balance) and hydraulic balance area. This approach will help ensure that the vegetation is maintained, at least on the area required to satisfy the hydraulic balance and reduce the likelihood of vegetation die-off over the whole area in extended dry periods.
- Careful hydraulic design is needed to ensure appropriate equipment selection and satisfactory operation.
- Protect the effluent irrigation area from potential run-on and stormwater by constructing an upslope diversion drain or berm. Standard Drawing 1 (Appendix 4) shows the construction of such a diversion drain/berm.
- Choose an appropriate pump that can adequately service the demands of the designated effluent irrigation area. It must overcome the friction loss and headloss in the system and meet the required head and irrigation flow rates of the selected emitters at the most distant point in the system. The effluent irrigation area may need to be split into two or more zones, supplied via a distribution or sequencing valve. Individual zones should be no larger than 400 square metres (typically 250 to 300 square metres).
- Design the system to deliver an appropriate dosing volume that fully charges the irrigation lines in each field. Non-return valves may be required.
- Program irrigation to ensure even delivery of effluent to the fields in the effluent irrigation area.
- Irrigation system components need to be carefully selected and specified to ensure satisfactory operation. The standard irrigation kit supplied with many aerated wastewater treatment systems is **not** suitable for most sites.
- The distribution pipe should be 25 millimetre uPVC or polyethylene pipe, buried 300 millimetres underground.
- Use only subsurface drip line designed specifically for effluent irrigation. Pressure-compensating subsurface drip line (typically 16 millimetre) is used with emitters (Figure 13.4) and laterals at approximately 600 millimetre spacings (a maximum of 1,000 millimetre spacings) and buried 100 to 150 millimetres deep. A pressure regulator may be needed where non-pressure compensating line is used. This is only relevant for use with a wick-based system.
- Adequate filtration must be incorporated in the system. Install a disc filter or a 100 to 150 micron mesh filter before the sequencing valve. The filter must be cleaned regularly – at least every three months. A filter flush valve should be fitted downstream of the field flush valve (See Standard Drawing No. 13A).

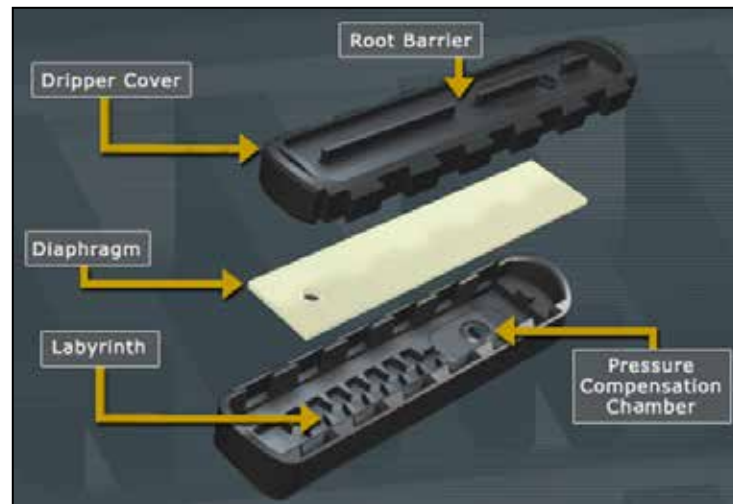

**Figure 13.4 Pressure compensating drip emitter (Netafim, 2018)**

- If the design incorporates supply and flush manifolds it is essential that to achieve flushing to all laterals the supply manifold is fed from the opposite end to the end the flushing manifold is drained from. This applies to manual and auto flushing system equally.
- Flushing is essential to remove floc sheared off the growth of material from inside the pipe work. This is particularly important if chlorine is not used for disinfection. Treated effluent contains dissolved oxygen and nutrients which encourage biofilm growth inside the pipework.
- Either use drip line impregnated with root inhibitor, or use a tech filter that dispenses a root inhibitor (commonly Triflualin) to protect drip line from root ingress. A wick-based system (see also Section 13.2) may reduce the susceptibility of the drip lines to root incursion.
- The design specifications of the system must be clearly communicated to the system installer. A licensed contractor should install the system and complete and sign the Installation Certificate. Council should inspect the installed system to ensure that it meets the design specifications.
- An aerated wastewater treatment system or other secondary treatment system must provide adequate treatment and be serviced regularly to ensure the irrigation system does not become clogged with suspended solids or organic material.
- The system should use timed dosing, particularly where load generation varies over time. This will require an adequately sized pump well to be incorporated.
- Air release valves need to be installed at high points in each area or field, and additional air release valves may be needed in undulating terrain.
- Incorporate air/vacuum valves, pressure-reducing valves and non-return / tube non-leakage valves into the design as needed. The non-leakage valve shuts off flow through the valve when line pressure drops below a selected pressure and opens and passes flow when the line pressure exceeds a higher selected pressure. This removes the need for the irrigation system to refill at the beginning of each irrigation cycle by holding pressure in the irrigation lines and keeping them filled. This ensures the system reaches operating pressure in minimum time. It also prevents the system draining to the lowest point where it is installed on a slope and ensures more even distribution of the effluent. The air/vacuum relief valve serves two purposes – it evacuates air from the laterals during system start-up and prevents a vacuum forming after the pump turns off. This prevents debris getting into the drippers at the higher locations in the field.

- The system must have the capacity for flushing to remove any suspended solids and organic growth that may accumulate. A field flush valve must be installed on the return line to facilitate flushing back to the treatment system, an in-field soakage pit or a small (maximum of 10m long x 0.6m wide x 0.7m deep) self-supporting arch absorption trench. Ensure that chlorinated effluent is not returned to the primary chamber of the treatment system where the chlorine may adversely affect the biological treatment processes. The flushing return manifold should be 25 millimetre uPVC or polyethylene line buried at 300 millimetres.
- Fit a non-return valve where the effluent irrigation area is located above the treatment system or pump well.
- Additional hydraulic design will be needed where effluent irrigation area slopes exceed 10% (5.7°). For example, the design may need a much larger pump for the head required to evenly distribute the effluent throughout the effluent irrigation area, or where the effluent irrigation area is at some distance from or height above the wastewater treatment system.
- Consideration should be given to the requirement for wet weather storage or emergency storage. The volumes required are calculated by hydraulic balance. Where possible, avoid wet weather storage by providing an adequate effluent irrigation area. Occasionally on constrained sites, a system may be designed to store the treated effluent during extended wet weather and then dose the effluent to the effluent irrigation area after the soil has dried out. Provision may also be made by having an appropriately sized absorption trench connected to the outlet chamber of the treatment system through a gravity fed transfer pipe. Providing this type of storage makes an allowance until repairs can be made that may be needed if components, such as pumps, malfunction.
- Adequately vegetate the effluent irrigation areas with species suited to effluent irrigation before the irrigation system is commissioned.
- Erect adequate signs to indicate that the area is being irrigated with treated effluent.
- Erect fencing or plant shrubs around the edge of the effluent irrigation area to protect it and prevent access by vehicles, livestock, domestic animals or children.

Other useful and detailed information about designing subsurface irrigation systems and choosing appropriate components is available on the websites of the major subsurface irrigation technology suppliers.

### Hydraulic design

A suitably qualified consultant must prepare a hydraulic design of the effluent irrigation area. The hydraulic design is essential to ensure the irrigation system will work effectively and distribute the effluent evenly.

## 13.2 Wick system

A subsurface textile irrigation delivers water directly to the root zone at a rate that matches the soil capillary action. The design enhances uniform vegetation growth, reduces waterlogging and drainage losses caused by deep drainage and tunnelling, and minimises soil salinity levels. The system deters root intrusion without using chemicals and can be fully automated.

Water is supplied to the soil from the surface of a geotextile fabric instead of from individual emitters in a drip line. Dispersing the water over a larger area reduces the rate of water discharged to the soil bringing it closer to the capillary absorption rate. It also converts the dripline from a series of point sources to a single, broad line source (Figure 13.5).

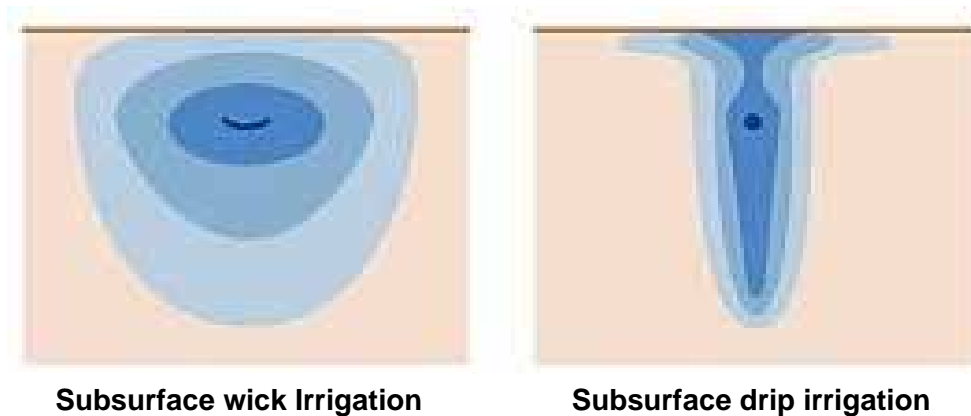

Figure 13.5 Irrigation wetting patterns

### 13.3 Installation

A number of installation techniques should be used for effective long-term operation of a subsurface effluent irrigation area. Common failures of irrigation systems are often caused by poor installation practices. System installation needs to be carefully timed in relation to other construction activities (e.g. for a dwelling) so that the irrigation system is not destroyed or damaged during construction activity. Follow the additional steps below when installing a subsurface irrigation system.

Checklist 13.1 outlines features of a subsurface drip irrigation system that should be checked on installation.

#### **Step 1**            **Site preparation**

Obtain a copy of the council approved plans and conditions of consent. Accurately locate irrigation areas as indicated in the consent, on the site plans and according to the specified and approved design and/or any covenant. Check the location of the irrigation system against the approved site plans and if there is any change in the position from the site plans; ask Council if a Modification of consent must be made to council to alter their position.

#### **Step 2**            **Positioning**

Ensure the laterals of an irrigation system are built along the contours to ensure even distribution. This will avoid more heavily loading part of the area, which can lead to premature failure of the effluent irrigation area.

#### **Step 3**            **Excavation**

Bury irrigation lines and distribution laterals 100 to 150 millimetres below natural ground level to ensure irrigation occurs in the root zone and protect against UV damage and lawn mowers. These lines can be installed with a small trench digger.

The main distribution line from the treatment system to the effluent irrigation area and the return flush manifold to the wastewater treatment system must be buried at least 300 mm deep and in a manner that protects against mechanical damage or deformation (see also Table 2.8).

#### **Step 4**            **Construction**

Install the irrigation distribution laterals, then flush and check the lines for leaks or breaks before backfilling.

Turf or plant grass over the effluent irrigation area to establish vegetation cover promptly after construction. This ensures the best uptake of effluent by evapotranspiration. Ensure that deep rooted plant species are not planted close to irrigation lines, to reduce the chance of roots intruding and clogging the laterals.

Construct a stormwater diversion drain or berm above the effluent irrigation area on sloping sites to avoid stormwater run-on. Standard Drawing 1 (Appendix 4) provides detail on constructing a stormwater diversion drain/berm.

**Step 5**                    **Dosing**

The pressure-dosed irrigation system should evenly distribute the effluent throughout the entire effluent irrigation area. Annotated Standard Drawing No. 13A details the installation of a subsurface effluent irrigation area.

Where the water table is high or a shallow subsurface limiting layer reduces the depth of free draining soil the effluent can pass through, or where soil storage is otherwise limited, consider building a raised subsurface irrigation bed. Annotated Standard Drawing No. 13B details installation of a raised subsurface irrigation bed.

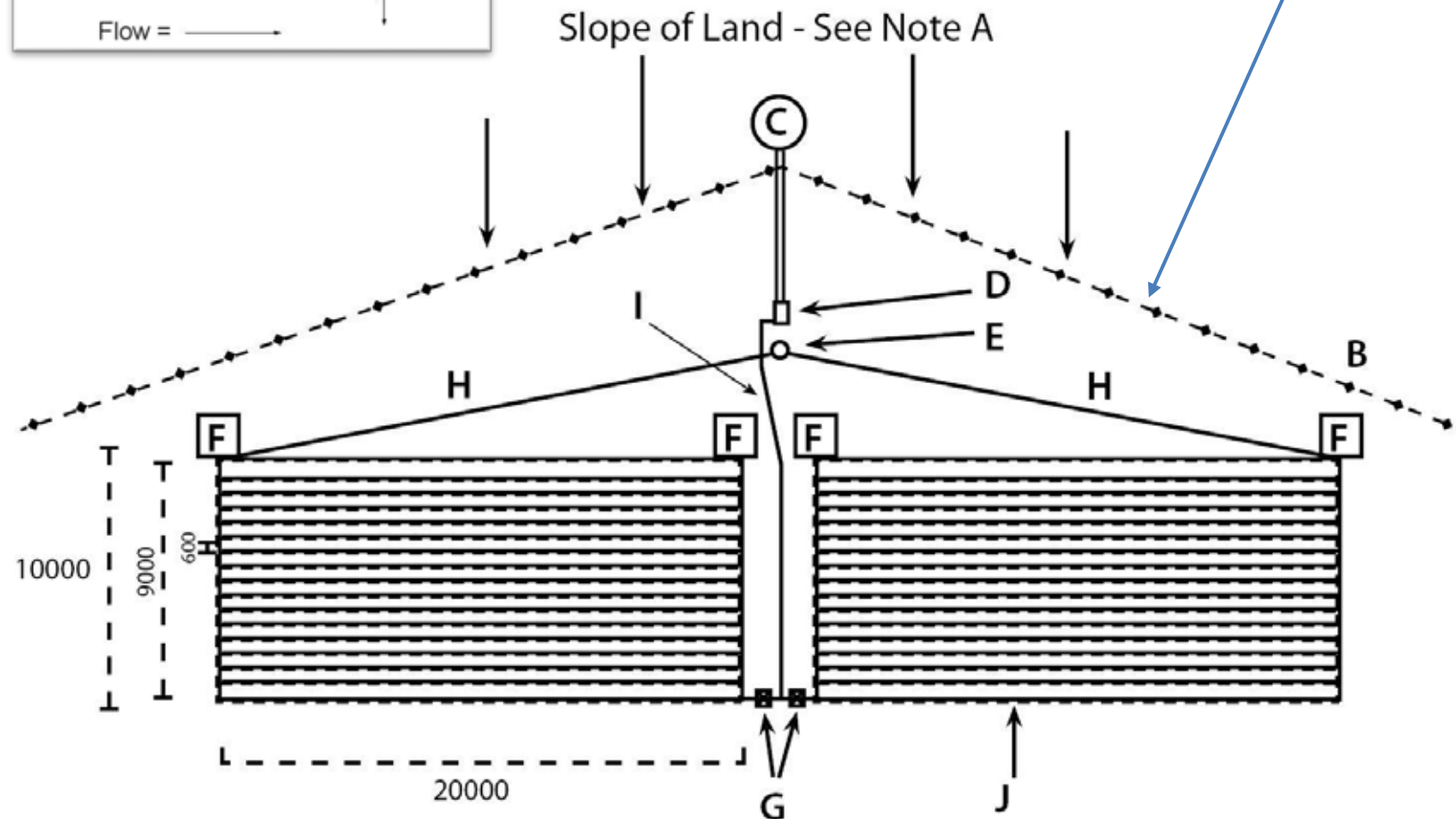
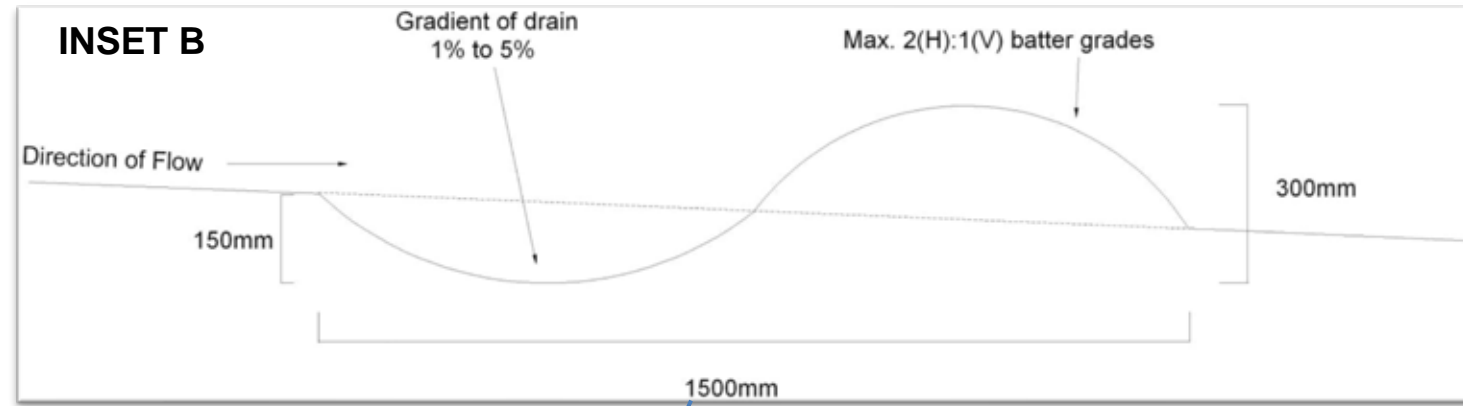
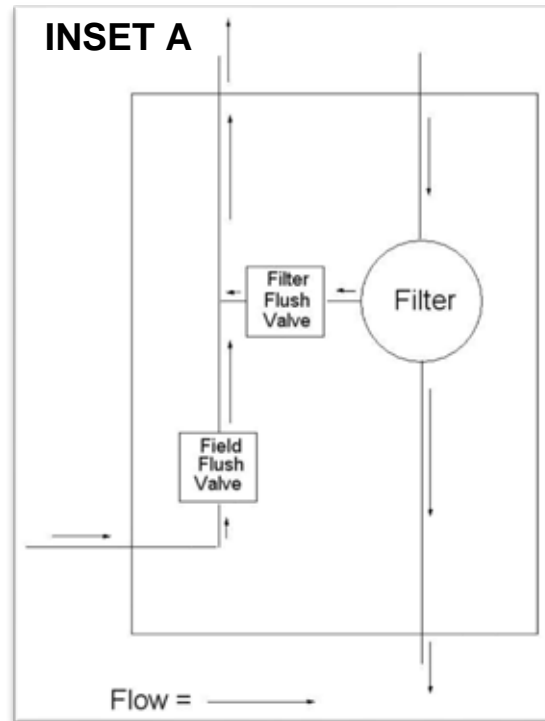

### Subsurface Irrigation Area Construction

- A** Design for relatively uniform slope. Additional design work may be required where slope exceeds 12% or if system is to be installed over undulating ground.
- B** An earth bank diversion drain must be constructed upslope of the area to divert stormwater run-on if this is appreciable (see Inset B and Standard Drawing 1).
- C** Secondary treatment system – the irrigation pump must provide a *minimum* 20 m head and a flow rate that matches the design output of the selected dripline. Flow rate will vary depending on emitter spacing, flow rate and lineal metres of line. A full hydraulic design must be carried out. Each area should be capable of discharging a minimum of 80 L/min.
- D** Filtration and flushing mechanism (see Inset A) – a field flush valve must be installed on the return line to facilitate periodic flushing to the treatment tank. An additional filter flush valve should be installed downstream of the field flush valve. A 100-150 micron cylindrical filter should be installed and cleaned regularly. Where there are potential problems in returning irrigation field flush back to the treatment tank, a small (approximately 3 m x 0.6 m) absorption area sited below the effluent irrigation area can be used to accommodate the flushed effluent.
- E** An automatic, hydraulically operated sequencing valve should be installed to deliver effluent evenly to the two areas.
- F** Air release valves must be installed at high points in each area. Additional air release valves may be required in undulating terrain.
- G** Check valves are required for each irrigation field to facilitate periodic flushing.
- H** Distribution manifolds should be 25 mm uPVC or polyethylene pipe buried 300 mm below the ground surface.
- I** Flushing return manifold should be 25 mm uPVC or polyethylene pipe buried 100-150 mm below the ground surface within the irrigation area. Outside this area, the pipe must be buried at a minimum of 300 mm depth.
- J** Pressure compensating (PC) subsurface drip line laterals (typically 16 mm) with emitters and laterals at approximately 600 mm spacings (maximum 1,000 mm spacings) and buried to a depth 100-150 mm. Only subsurface dripline specifically designed for effluent irrigation must be used.

*This standard design has been based on a generic area of 400 m<sup>2</sup> for irrigation based on typical conditions. It does not eliminate the need for a site and soil evaluation to be carried out or any additional consideration of site specific issues. It should be used as a generic guide only.*

**Standard Drawing 13A – Subsurface Effluent Irrigation**  
(not to scale)



Checklist 13.1 Installation of subsurface irrigation systems		
Owner:		
Address:		
Installation date:		
Irrigation area coordinates:		
Do you have a copy of the consent / approval?	<input type="checkbox"/> Yes	<input type="checkbox"/> No
Approval number/ reference:		
Does it specify the nature / sizing / location of the effluent irrigation area?	<input type="checkbox"/> Yes	<input type="checkbox"/> No
Is the irrigation system located as detailed in the conditions of consent / approval?	<input type="checkbox"/> Yes	<input type="checkbox"/> No
Headworks		
Is the control panel/controller installed according to manufacturer's instructions and the irrigation system design details?	<input type="checkbox"/> Yes	<input type="checkbox"/> No
Is a foot valve fitted to the suction inlet in the treated effluent tank?	<input type="checkbox"/> Yes	<input type="checkbox"/> No <input type="checkbox"/> N/A
Is an appropriate pump installed according to the manufacturer's specifications and/or the irrigation system design requirements?	<input type="checkbox"/> Yes	<input type="checkbox"/> No
Is a standby pump available for the system?	<input type="checkbox"/> Yes	<input type="checkbox"/> No <input type="checkbox"/>
If yes, has it been installed, stored or available within 24 hours?	<input type="checkbox"/> Yes	<input type="checkbox"/> No <input type="checkbox"/> N/A
Is a permanent pressure gauge installed following the pump?	<input type="checkbox"/> Yes	<input type="checkbox"/> No
Is a non-return valve installed following the pressure gauge?	<input type="checkbox"/> Yes	<input type="checkbox"/> No <input type="checkbox"/>
Is an appropriate filter with 100-150 micron filter installed?	<input type="checkbox"/> Yes	<input type="checkbox"/> No
Are any solenoid valves, cabling, sequencing or Manual valves installed to enable alternate dosing of the irrigation fields according to the design?	<input type="checkbox"/> Yes	<input type="checkbox"/> No <input type="checkbox"/>
Is the controller capable of operating the specified pump, filter and any solenoid valves for the irrigation fields according to the design?	<input type="checkbox"/> Yes	<input type="checkbox"/> No
Has the controller been tested to operate satisfactorily for each field?	<input type="checkbox"/> Yes	<input type="checkbox"/> No <input type="checkbox"/>
Is a low level cut-off float switch installed in the effluent tank that overrides the irrigation controller to prevent the system pumping dry?	<input type="checkbox"/> Yes	<input type="checkbox"/> No <input type="checkbox"/> N/A
Is a high level cut-in float switch installed in the effluent tank that overrides the standard irrigation schedule during times of high flow?	<input type="checkbox"/> Yes	<input type="checkbox"/> No <input type="checkbox"/> N/A
Have the headworks been installed and located according to the design?	<input type="checkbox"/> Yes	<input type="checkbox"/> No
Do the headworks meet the hydraulic specifications of the design?	<input type="checkbox"/> Yes	<input type="checkbox"/> No <input type="checkbox"/>
Mainline and dosing pipeworks		
Does all pipework match the size, pressure class specifications detailed in the design?	<input type="checkbox"/> Yes	<input type="checkbox"/> No

<b>Checklist 13.1 continued</b>		
Is all pipework installed, tested and commissioned according to <a href="#">AS/NZS 2566.2:2002 (R2016)/AMDT 2:2018 Buried flexible pipelines Installation</a> ?	<input type="checkbox"/> Yes	<input type="checkbox"/> No
Are all pipe fittings, clamps and joints made to match the pressure class of the pipe at that location?	<input type="checkbox"/> Yes	<input type="checkbox"/> No
<b>Drip line and field layouts</b>		
Is all installed drip line according to the design (e.g. pressure compensating, anti-siphon) with 600mm dripper spacings and 1.6 L an hour dripper flow rate?	<input type="checkbox"/> Yes	<input type="checkbox"/> No
Is all dripline installed under mulch or soil according to the hydraulic design?	<input type="checkbox"/> Yes	<input type="checkbox"/> No
Are dripline laterals spaced between 600 – 1,000mm (ideally 600mm spacings)?	<input type="checkbox"/> Yes	<input type="checkbox"/> No
Do all laterals comply with appropriate buffer distances?	<input type="checkbox"/> Yes	<input type="checkbox"/> No
Are the connections of laterals to mainlines, sub-mains and flushing manifolds according to the manufacturer's recommendations?	<input type="checkbox"/> Yes	<input type="checkbox"/> No
Is all dosing and flushing pipework according to the manufacturer's recommendations?	<input type="checkbox"/> Yes	<input type="checkbox"/> No
Are air/vacuum release valves installed at all significant high points in each field?	<input type="checkbox"/> Yes	<input type="checkbox"/> No
Is a flushing valve installed at the end of each flushing manifold as recommended by the manufacturer?	<input type="checkbox"/> Yes	<input type="checkbox"/> No
Has the field flush valve been connected back to the treatment system?	<input type="checkbox"/> Yes	<input type="checkbox"/> No
Has the field flush valve been directed to a small absorption trench (approximately 3 m x 0.6 m)?	<input type="checkbox"/> Yes	<input type="checkbox"/> No
Does each field have the facilities for measurement of pressure (e.g. needle test point or similar) immediately before the entrance to the first lateral and immediately following the exit of the final lateral?	<input type="checkbox"/> Yes	<input type="checkbox"/> No
Do the installed dripline subsections meet the hydraulic specifications detailed in the design?	<input type="checkbox"/> Yes	<input type="checkbox"/> No
<b>Drip line fields hydraulic design</b>		
Is the operating pressure at the pump within 10% of that specified for each field at the time of commissioning?	<input type="checkbox"/> Yes	<input type="checkbox"/> No
Is the operating pressure at the pump within 10% of the design value?	<input type="checkbox"/> Yes	<input type="checkbox"/> No
Is the pressure difference between the entrance to the first lateral and exit of the last lateral less than 15%?	<input type="checkbox"/> Yes	<input type="checkbox"/> No
Are all flushing velocities greater than 0.4m/s for all fields?	<input type="checkbox"/> Yes	<input type="checkbox"/> No
<b>Commissioning and testing</b>		
Have all mainlines and sub-mains been commissioned and tested according to <a href="#">AS/NZS 2566.2:2002 (R2016)/AMDT 2:2018 Buried flexible pipelines Installation</a> ?	<input type="checkbox"/> Yes	<input type="checkbox"/> No

Checklist 13.1 continued		
Has the pump, filter and control equipment been commissioned and tested according to the manufacturer or supplier specifications?	<input type="checkbox"/> Yes	<input type="checkbox"/> No
Have all drip line field layout, connections and fittings been checked before covering?	<input type="checkbox"/> Yes	<input type="checkbox"/> No
Have all fields been flushed with clean water adequately before pressurising to remove construction debris that may have accumulated during installation?	<input type="checkbox"/> Yes	<input type="checkbox"/> No
Have all drip line fields been tested for leakage from joints and fittings before covering?	<input type="checkbox"/> Yes	<input type="checkbox"/> No
Have all operating pressures been checked at the pump and the end of each field or subsection at the time of commissioning according to the design?	<input type="checkbox"/> Yes	<input type="checkbox"/> No
Has Council inspected the system before backfilling?	<input type="checkbox"/> Yes	<input type="checkbox"/> No
Has the owner/operator been provided with an Operation and Maintenance Manual, including layout?	<input type="checkbox"/> Yes	<input type="checkbox"/> No
<b>Comments, action or repairs needed:</b> (Where a response in this checklist needs extra information or action, specify the action plan and/or the process to fix the problem, or specify an alternative that is being offered)		
<b>Service provider:</b>  <b>Title:</b>  <b>Contact number:</b>		
<b>Name of inspector:</b>		
<b>Signature:</b>	<b>Date:</b>	

## 13.4 Inspection

Council should inspect the irrigation system before backfilling to ensure all components are installed according to '[AS/NZS 2566.2:2002 \(R2016\)/AMDT 2:2018 Buried flexible pipelines Installation](#)'. Council should make a final installation inspection to ensure compliance with all conditions of consent before issuing an approval to operate the system.

## 13.5 Operation

A subsurface irrigation system needs regular maintenance in addition to the quarterly service inspection. System owners are usually responsible for this operational maintenance, including:

- regularly mowing the effluent irrigation area and disposing of grass clippings outside the effluent irrigation area
- regularly cleaning filters installed on irrigation systems as per the manufacturer's specifications. Where these filters are used, system owners are responsible for regularly cleaning them
- back flushing irrigation lines to remove any biofilm build up and prevent blockages.

Plumbers, council inspectors and system owners can use Checklist 13.2 to inspect operating surface irrigation systems (as well as the standard quarterly inspection by the service provider). The checklist can be used to ensure the irrigation system is operating appropriately and for council compliance inspections.

Checklist 13.2 Operation inspection <sup>(1)</sup> of effluent management area for use by service agents, Council inspectors and system owners			
Owner:			
Address:			
Installation date:			
Effluent Management Area coordinates:			
Does the system owner have a set of plans of the irrigation system and an Operational and Maintenance Manual? <input type="checkbox"/> Yes <input type="checkbox"/> No			
Effluent Management Area			
Is there evidence of irrigation area damage by vehicle, livestock or domestic animal activities?	<input type="checkbox"/> Yes	<input type="checkbox"/> No	Comment:
Is a good vegetation cover established over the effluent irrigation area?	<input type="checkbox"/> Yes	<input type="checkbox"/> No	Comment:
Are there any green or boggy areas or surface ponding of effluent liquid in the irrigation area?	<input type="checkbox"/> Yes	<input type="checkbox"/> No	Comment:
Are there dry areas or areas lacking vegetation in the irrigation area?	<input type="checkbox"/> Yes	<input type="checkbox"/> No	Comment:
Is the effluent irrigation area associated with an unpleasant smell that would suggest untreated or poorly treated effluent is being used to irrigate?	<input type="checkbox"/> Yes	<input type="checkbox"/> No	Comment:
Has the effluent irrigation area been mown to maintain the grass short?	<input type="checkbox"/> Yes	<input type="checkbox"/> No	
Treatment and Irrigation System			
Is any stormwater run-on effectively diverted around the irrigation area?	<input type="checkbox"/> Yes	<input type="checkbox"/> No	
Is the irrigation pump working?	<input type="checkbox"/> Yes	<input type="checkbox"/> No	
Is the irrigation system working without leaks?	<input type="checkbox"/> Yes	<input type="checkbox"/> No	
Has the effluent irrigation area been back flushed?	<input type="checkbox"/> Yes	<input type="checkbox"/> No	
Have the irrigation filters been checked and cleaned?	<input type="checkbox"/> Yes	<input type="checkbox"/> No	
Does the system require air bleeding?	<input type="checkbox"/> Yes	<input type="checkbox"/> No	
If an automatic sequencing valve is fitted, does it switch between the different fields sequentially?	<input type="checkbox"/> Yes	<input type="checkbox"/> No	
If a Manual valve is fitted, has it been switched between the different fields?	<input type="checkbox"/> Yes	<input type="checkbox"/> No	
Is the irrigation area still adequately protected from livestock, vehicles, children etc. through the use of fencing, or shrub barriers etc.	<input type="checkbox"/> Yes	<input type="checkbox"/> No	
Is there any inappropriate use of the irrigation area e.g. vegetable growing?	<input type="checkbox"/> Yes	<input type="checkbox"/> No	
<b>Note:</b> if as a system owner, you answered 'No' to any of the above questions, or there are any other problems, you should contact your service provider immediately.			

<p><b>Comments, action or repairs needed:</b> (Where a response in this checklist needs extra information or action, specify the action plan and/or the process to fix the problem, or specify an alternative that is being offered)</p>	
<p><b>Service provider:</b></p> <p><b>Title:</b></p> <p><b>Contact number:</b></p>	
<p><b>Name of inspector:</b></p>	
<p><b>Signature:</b></p>	<p><b>Date:</b></p>

<sup>(1)</sup> In addition to the standard quarterly inspection by the service provider.

## 13.6 Common technical issues

Plumbers, property owners and regulatory authorities have observed a number of common problems with subsurface irrigation installations including:

- not installed as per the approved design and specification
- inadequate hydraulic design:
  - resulting in uneven distribution
  - resulting in hydraulic overloading and saturation where the effluent irrigation area is too small. This can be worsened if owners supplement the irrigation with other sources to try to establish and maintain unsuitable plant species that need more water to survive. Subdivide effluent irrigation areas so that the size of each field can be adequately serviced by the pump, and irrigated sequentially using a distribution or sequencing valve
  - resulting in the hydraulic load reaching the more distant ends of irrigation lines and overloading the nearer ends of the irrigation lines (where the irrigation fields are too large).
- pump capacity does not meet the needs of the irrigation system. This is a common problem where the capacity of pumps supplied with many aerated water treatment systems is exceeded because the effluent irrigation fields are too large, too far away, or upslope of the treatment system. Typically, an irrigation pump must provide at least 20 metres head. The flow rate will vary depending on the emitter spacing, and the length of irrigation line. Each field should be able to discharge 80 litres per minute. If the pump is too small, flow distribution will not be uniform
- not enough irrigation lines installed to adequately distribute effluent over the required effluent irrigation area
- appropriate buffer distances are not accommodated
- irrigation onto sites that are too steeply sloping, causing surface breakout
- using non-pressure compensating lines or not laying them on the contour causing preferential irrigation of low points in irrigation lines
- irrigation lines become blocked due to treatment failure or inadequate filtration of effluent or lack of flushing capability
- inappropriate or too-wide line spacing or loading causing striping of lawns
- effluent irrigation area not maintained and grass not mowed.

## 13.7 Case study

An aerated wastewater treatment system was installed for a new home. Council and WaterNSW required all effluent to be applied using subsurface irrigation of lawn areas around the new home, to ensure appropriate buffer distances from a nearby watercourse. Approximately 800 square metres of drip line was installed on unvegetated ground with very thin soil and a significant amount of exposed rock. The effluent was distributed by a main distribution line from the system. The contractor laid the irrigation line and connected it to the aerated wastewater treatment system. The area was left without vegetation for a period of time, although the family had moved in and was using the system (Figure 13.6). There were a number of problems including:

- the surrounding soil began to erode and wash away as effluent was applied to the soil
- the pipes deteriorated from natural UV light and surrounding activities that caused cracks and breaks in the lateral
- the area became infested with weeds.



**Figure 13.6** Poorly installed subsurface effluent irrigation system

The contractor was asked to move the effluent irrigation area to specified areas around the home according to council and WaterNSW requirements. The irrigation lines were removed from the downslope area and re-laid in the turfed areas around the home, upslope of the aerated wastewater treatment system.

Within weeks the new effluent irrigation area again showed signs of failure and the property owner observed surface ponding. The irrigation pump failed and activated the high-level alarm. Investigations identified the following issues:

- the perished and brittle irrigation lines had not been replaced and cracks and breaks in the lines (Figure 13.7) caused excessive application of effluent to some areas. This exceeded the hydraulic capacity of the soil and caused surface ponding
- the irrigation pump was too small and could not pressurise such a large single area of irrigation lines (it could not overcome the friction loss and headloss in the system)
- the large single field was laid on rock in thin soil (Figure 13.8)
- no flushing valves were installed.

The following rectification measures were then undertaken by the contractor:

- removing the damaged irrigation pipes and replacing them with new subsurface irrigation lines
- installing a suitably sized irrigation pump in the aerated wastewater treatment system
- splitting the irrigation into a number of zones (Figures 13.9 and 13.10)
- installing an auto-sequencing valve.



**Figure 13.7**  
Damaged irrigation line sections cut out and replaced as part of an unsatisfactory repair.



**Figure 13.8**  
Rock outcrop and thin soils in original effluent irrigation area



**Figure 13.9**  
One of the new zones at the rear of the property established upslope of the aerated wastewater treatment system on imported soil



**Figure 13.10**  
**Second zone established at front**  
**of property on imported soil**

The following design measures could have prevented these problems:

- preparing a hydraulic design for the subsurface effluent irrigation area (and zones) and system components (including the irrigation pump)
- locating and installing the effluent irrigation area as specified by the hydraulic design, council and WaterNSW
- burying all irrigation dripper lines, laterals and distribution lines below ground to prevent UV deterioration
- vegetating or turfing the effluent irrigation area immediately after installation with suitable plant/grass species
- fitting the irrigation system with a flushing manifold
- dividing the effluent irrigation area into a number of smaller zones to ensure even distribution throughout the area
- installing an automatic sequencing valve to allow effluent irrigation areas to be irrigated alternately without the owner needing to switch the zones
- Council inspecting the installation to ensure compliance with requirements
- making the installer (and property owners) aware of the proposed system, the conditions of consent and their obligations to complete the system installation including testing the system and vegetating the irrigation area
- the installer certifying that the system was installed as needed and designed.

## 14 Supplementary Technology

This section of the Manual describes some supplementary technologies that designers, installers and regulators in the Sydney drinking water catchment may encounter or wish to use.

### 14.1 Treatment Wetlands

Treatment wetlands, such as reed bed systems to treat and dispose of effluent, may be considered in exceptional circumstances (only on a case-by-case basis). Where the design is based on peak loads, the calculated size of the reed beds would be too large for sustainable vegetation growth in the drier parts of the Sydney drinking water catchment. The nutrient uptake of the vegetation is less in colder climates, and in high rainfall areas system overflows can be a problem.

Further information on wetland systems for treatment of domestic wastewater can be found in *The Use of Reed Beds for the Treatment of Sewage & Wastewater from Domestic Households* (Lismore City Council, 2005).

### 14.2 Membrane systems

A small number of advanced AWTS accredited in NSW use membrane technology, and are recognised as effectively reducing nutrients to relatively low levels. The membranes may be organic or inorganic and in the form of hollow fibres or more commonly flat plates. In domestic systems they typically provide microfiltration which removes most bacteria but generally does not remove viruses. Whilst membrane systems can offer a relatively high level of treatment compared to systems without membranes, they have a higher capital cost. In addition, they require more extensive and costly servicing and typically use more energy than non-membrane systems. Lack of clarity over the durability of the membranes and their replacement costs are other important considerations for system owners and operators.

An indication of the potential nutrient reduction performance is noted in the NSW Health accreditation. Further information on NSW Health accredited AWTS using membrane technology is available from:

<https://www.health.nsw.gov.au/environment/domesticwastewater/Pages/awts.aspx>

### 14.3 Textile filter systems

Textile filter systems offer a relatively passive secondary treatment option with low energy usage. Such systems can achieve a high final effluent quality and are subject to less frequent servicing requirements than AWTS.

Further information on NSW Health accredited textile filter systems is available from:

<https://www.health.nsw.gov.au/environment/domesticwastewater/Pages/astfs.aspx>

### 14.4 Sand filters

Sand filter systems offer a relatively passive secondary treatment option with low energy usage. Such systems can achieve a high final effluent quality and are subject to less frequent servicing requirements than AWTS. There are a variety of sand filter designs available including single pass and recirculating sand filters. Sand filters should be designed and constructed by experienced personnel. It is critically important that suitable sand be utilised and that the sand be certified as meeting established design criteria for particle size and distribution. Designs should consider both hydraulic and organic loading rates. Sand filters should not be gravity fed. Pressure dosing through a drilled pipe distribution system is required and a hydraulic design for the distribution system should be completed as part of the overall design. Recirculating sand filters can offer significant nitrogen reduction in the final effluent.

Most commonly, sand filters would be individually designed for a specific setting.

Further information on sand filters can be found at:

<https://www.doh.wa.gov/CommunityandEnvironment/WastewaterManagement>.

Further information on NSW Health accredited sand filters is available from:

<https://www.health.nsw.gov.au/environment/domesticwastewater/Pages/astfs.aspx>.

## 14.5 Subsurface Media Treatment Systems

Subsurface media treatment systems such as the Advanced Enviro-Septic® (AES) system are an alternative effluent management option that offers additional treatment within a series of proprietary large diameter pipes set within and above a bed of filter sand. The AES Lined Sand Filter system (AES-38-SPD) has been accredited as a secondary treatment system in NSW. However, the accreditation requires the AES to have pre-treatment via an accredited septic tank and the sand filter to be lined with wastewater directed to a chlorinator and a separate land application system.

While the unlined AES provide a degree of additional treatment prior to percolation into the natural soil, given accreditation only applies to a lined sand filter with chlorination and separate land application system, Water NSW requires design loading rates for primary treated effluent.

Design and installation of AES systems should only be undertaken by experienced personnel.

It is important that suitable sand be utilised and that the sand be certified as meeting established design criteria for particle size and distribution. The basal loading rate for the sand bed should be based on any limiting soil layer within 600mm beneath the base of the bed. The capacity of the sand bed beneath the AES system should be confirmed by the use of a water balance to ensure that the sand bed does not become saturated, as the treatment capacity will be impaired if the sand bed is not free-draining.

## 14.6 Buffering / balance tanks

The use of buffering or balance tanks can assist in delivering uniform loads to both treatment systems and effluent management areas. This is particularly useful in situations where wastewater generation rates are irregular, for example at irregularly occupied premises such as a meeting room, function centre, church, school or restaurant. Flow balancing is used to collect and store the irregularly generated loads in a balance tank prior to regular dosing by a timer controlled pump to the treatment system. This will assist in maintaining a regular flow to the treatment system, which often ensures improved treatment performance and avoids overloading with peak loads. Similarly, the use of a balance tank prior to effluent management can ensure regular and even dosing of the effluent management area and help avoid saturation due to peak flows.

Balance tanks offer a low cost solution to many problems encountered at sites where wastewater generation rates vary significantly over time.

Design and installation of balance tanks and timer controlled pumps should be undertaken by suitably experienced personnel and designs should be supported by detailed hydraulic calculations to consider generation rates and volumes, required storage capacity prior to treatment and effluent management and appropriate dosing rates for effective treatment and effluent management.

## 14.7 Dosing mechanisms

Two technologies that help with dose loading are described – the dosing siphon and the “Flout™”. Dose loading greatly improves performance compared with passively gravity feeding effluent management areas. This technology can provide a low pressure dose of effluent in a similar to a pump, without requiring a power supply. This passive technology is well suited to remote sites where there is interrupted or no mains power supply. Low pressure dosing by such dosing devices ensures even distribution and avoids creeping failure commonly associated with gravity

fed systems. These low cost alternatives can result in significantly better performance of sand and media filters and effluent management systems and can significantly prolong their effective life.

### 14.7.1 Dosing siphon

Dosing siphons (Figures 14.1 and 14.2) are used extensively in the USA and are becoming more readily available from on-site wastewater system suppliers in Australia. They change low or variable flows into regular doses and suit pressurising laterals and effluent management areas. They have no moving parts and need no electricity. They are typically used with sand filters (Figure 14.3) or absorption trenches/beds or evapotranspiration absorption beds.

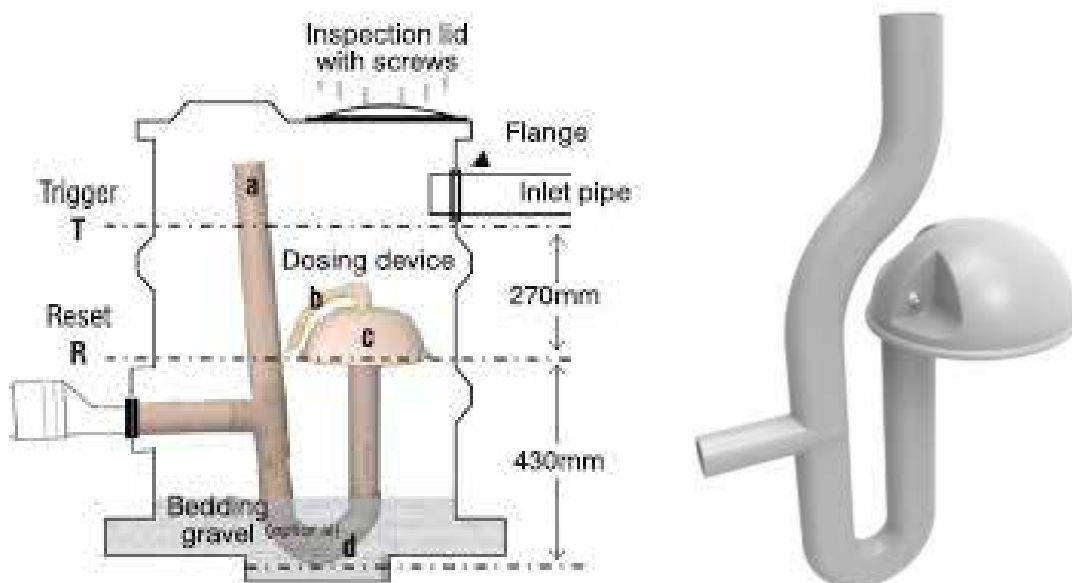

Figure 14.1 The dosing siphon (Surge-flow 100)

An outlet filter must be fitted to the septic tank. Effluent is collected by gravity feed into a dosing chamber where the siphon is located. Effluent rises in the dosing chamber to the point where the dosing siphon is triggered. The volume of dose is determined by the diameter of the dosing chamber. After the dose is dispensed, the siphon breaks and the flow ceases. The siphon reliably resets and is automatically triggered again when the effluent level in the dosing chamber returns to the trigger level. Siphons are a low-cost alternative to pumps and suit sites with no power or where power availability is limited. A fall of about 1.5 metres from the dosing chamber to the effluent management area is needed for the siphon to operate properly.



Figure 14.2 Dosing siphon in dosing chamber (Surge-flow 100)



Figure 14.3 Siphon being tested delivering pressure dosed load to a sand filter (Whitehead & Associates)

#### 14.7.2 "Flout<sup>®</sup>" Floating Outlet

The Flout<sup>®</sup> or Floating Outlet<sup>™</sup> is a trademarked proprietary product made by Rissy Plastics. It is a simple dosing distribution device that can be used to dose load an effluent management area from a dosing well (Figure 14.4 and 14.5). As effluent from the septic tank fills the dosing chamber, the Flout<sup>™</sup> (Figure 14.6) is empty, buoyant, and floats on the surface. High quality, flexible connectors allow the Flout<sup>®</sup> to rise. When the effluent reaches the maximum level in the chamber, it spills into the opening in the top of the Flout<sup>®</sup>. This causes the Flout<sup>®</sup> to sink (Figure 14.7). The effluent now discharges through the pipe exiting the dosing chamber and doses the effluent

management area. The chamber continues to empty down to the top of the Flout® (Figure 14.8). Then the Flout® empties and resumes floating to repeat another cycle. The Flout® can be used to dose load trenches and beds or effluent irrigation areas in some cases where there are differences in elevation between the treatment system and the effluent management area.

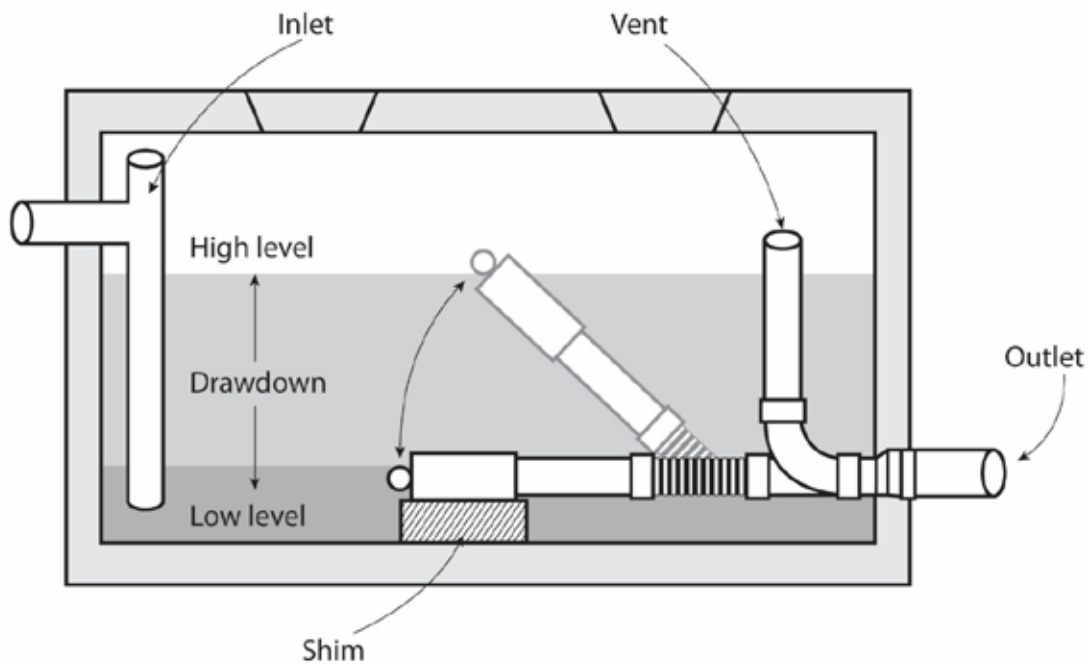

Figure 14.4 The Single Flout®



Figure 14.5 The Single Flout®



Figure 14.6 The Flout<sup>®</sup> is free floating



Figure 14.7 The Flout<sup>®</sup> reaches the maximum level in the chamber



Figure 14.8 The dosing chamber continues to empty down to the top of the Flout<sup>®</sup> (Figures 14.4 to 14.8 Rissy Plastics LLC)

## 15 Acronyms

<b>AWTS</b>	Aerated wastewater treatment system
<b>B&amp;C SEPP</b>	State Environmental Planning Policy (Biodiversity and Conservation) 2021
<b>BFS</b>	Biological filter system
<b>BOD<sub>5</sub></b>	5-day biochemical oxygen demand
<b>CRP</b>	Current recommended practice
<b>DIPNR</b>	Former Department of Infrastructure, Planning and Natural Resources
<b>DLG</b>	Department of Local Government
<b>DIR</b>	Design irrigation rate
<b>DLR</b>	Design loading rate
<b>EMA</b>	Effluent management area
<b>EP&amp;A Act</b>	Environmental Planning and Assessment Act 1979
<b>EP</b>	Equivalent persons
<b>ETA</b>	Evapotranspiration absorption (beds)
<b>FPL</b>	Flood planning level
<b>GIS</b>	Geographic Information Systems
<b>GTS</b>	Greywater treatment systems
<b>kPa</b>	Kilopascals
<b>NorBE</b>	Neutral or beneficial effect (on water quality)
<b>OLG</b>	Office of Local Government
<b>PC</b>	Pressure compensating
<b>SDWC</b>	Sydney Drinking Water Catchment
<b>SILO</b>	Scientific Information for Landowners (Long Paddock; QLD Government)
<b>TSS</b>	Total suspended solids
<b>uPVC</b>	Unplasticised (rigid) polyvinyl chloride
<b>UV</b>	Ultraviolet
<b>WEM</b>	Wastewater effluent model

## 16 Glossary

TERM	DEFINITION
<b>Accreditation</b>	All domestic on-site wastewater treatment systems (including greywater treatment systems) installed in NSW must be accredited by NSW Health.
<b>Building</b>	A Building includes part of a building, and also includes any structure or part of a structure (including any temporary structure or part of a temporary structure), but does not include a manufactured home, moveable dwelling or associated structure within the meaning of the <a href="#">Local Government Act 1993</a> .
<b>Catchment</b>	A hydrological catchment or area of land where surface water drains through a network of drainage lines and streams to a single outlet.
<b>Certifier</b>	A person or entity accredited to issue certain certificates and perform specific duties under the Environmental Planning and Assessment Act 1979. For on-site wastewater systems, only qualified staff from a council can certify systems under the <i>Local Government Act 1993</i> .
<b>Current Recommended Practice (CRP)</b>	Current recommended practice's and guidelines accepted or adopted by industry and natural resource management agencies to manage an aspect of the operation or development to ensure all activities are performed in a way that best protects the environment and water quality. A WaterNSW endorsed CRP provides particular measures that ensure water quality is protected. As per the B&C SEPP NorBE requirements, endorsed CRPs are to be used for developments or activities unless it can be shown that alternative measures will have equal or better water quality outcomes. A best management practice guideline is similar in concept to a CRP.
<b>Concurrence</b>	Concurrence is agreement from a government agency in relation to a development proposal in light of the agency's specialised functions and policies. Invariably the provision of concurrence to a consent authority will be subject to conditions. WaterNSW has a concurrence role in relation to proposed developments in the Sydney drinking water catchment.
<b>Consent authority</b>	(In the EP&A Act), in relation to a development application or an application for a complying development certificate, means: (a) the council having the function to determine the application, or (b) if a provision of this Act, the regulations or an environmental planning instrument specifies a Minister or public authority (other than a council) as having the function to determine the application—that Minister or public authority, as the case may be.
<b>Design loading rate</b>	(DLR) The long-term acceptance rate, reduced by a factor of safety, expressed in L/m <sup>2</sup> /day or mm/day as applied to the horizontal design area of a effluent management system. Usually applied to trenches and beds.
<b>Design irrigation rate</b>	(DIR) An aerial loading rate, expressed in L/m <sup>2</sup> /day or mm/day as applied to the horizontal design area of an irrigation system.
<b>Development</b>	Has the same meaning as in Part 5 of the Environmental Planning and Assessment Act 1979. (a) the use of land, (b) the subdivision of land, (c) the erection of a building, (d) the carrying out of a work, (e) the demolition of a building or work, and (f) any other act, matter or thing that may be controlled by an environmental planning instrument.

TERM	DEFINITION
<b>Development application</b>	An application for consent under Part 4 of the EP&A Act to carry out development but does not include an application for a complying development certificate.
<b>Drainage depression</b>	A low point that carries water during rainfall events but dries out quickly once rainfall has ceased. A gully or incised drainage depression is considered to constitute a watercourse.
<b>Dwelling</b>	means a room or suite of rooms occupied or used, or so constructed or adapted as to be capable of being occupied or used, as a separate domicile. <b>Inhabited dwelling</b> means a structure or part of a structure used as a home, residence or sleeping place, whether it is occupied or not.
<b>Drop box</b>	A watertight structure that receives septic tank effluent and distributes it into one or more distribution pipes and into an overflow leading to another drop box and absorption system located at a lower elevation. A type of distribution box, used for serial distribution.
<b>Effluent</b>	Treated wastewater
<b>Endogenous respiration</b>	A reduced level of respiration (breathing) where organisms break down compounds within their own cells to produce the oxygen they need.
<b>Equivalent Persons</b>	Equivalent persons (EP) are a measure of the demand or loading a development will have on infrastructure in terms of the average water consumption or average sewage discharge for an average person.
<b>Evapotranspiration</b>	Loss of water from the soil through evapotranspiration by plants.
<b>Flood planning levels (FPL)</b>	Is the combination of the flood level from the defined flood event and freeboard selected for flood risk management purposes.
<b>Greywater</b>	Domestic wastewater from sources other than toilets, including washing machines and dishwashers. Also generally excludes kitchen waste.
<b>Groundwater</b>	Groundwater is water collected in saturated layers of soil, sediment or porous rock below the land surface as aquifers. Aquifers in geological formations are permeable enough for water to move within them and be discharged or extracted.
<b>Headworks</b>	A wastewater main is classed as headworks when its main function is to: <ul style="list-style-type: none"> <li>• transfer wastewater between or to a treatment plant or transfer facility, and</li> <li>• perform the above function for the entire length between two access chambers.</li> </ul>
<b>Licensed contractor</b>	A contractor with at least three years' experience in their specialised field and licensed by the NSW Department of Fair Trading.
<b>NorBE</b>	NorBE is an abbreviation for the neutral or beneficial effect on water quality test as required by the State Environmental Planning Policy. All proposed developments under Part 4 of the <i>Environmental Planning and Assessment Act 1979</i> requiring consent must be able to demonstrate that they will have a neutral or beneficial effect on water quality. Whereas all Part 5 activities must consider NorBE. NorBE is demonstrated if a proposed development: <ul style="list-style-type: none"> <li>• has no identifiable potential impact on water quality, or</li> <li>• can contain any such impact on the site of the development <b>and</b> prevent it from reaching any watercourse, waterbody or drainage depression on the site, or</li> <li>• can transfer any such impact outside the site by treatment in a facility that will treat water to a required standard.</li> </ul>

TERM	DEFINITION
<b>NorBE guideline</b>	This guideline produced by WaterNSW collates relevant information and provides a clear direction as to what is meant by a neutral or beneficial effect on water quality, how to demonstrate it, and how to assess an application against the neutral or beneficial effect test. It also brings together relevant supporting information. The guideline is available at <a href="http://www.waternsw.com.au">www.waternsw.com.au</a> . Development consent will not be granted to development on land in the Sydney Drinking Water Catchment unless the consent authority is satisfied the development is consistent with the NorBE Guideline.
<b>NorBE Tool</b>	The NorBE Tool is a Windows-based GIS software application that guides the user to enter information derived from the information accompanying the development application e.g. the impervious area or the slope. Other data is automatically generated by the tool e.g. rainfall. The tool helps councils determine a neutral or beneficial effect or a WaterNSW concurrence role and records the decision process for each development application.
<b>Nutrients</b>	Substances such as phosphorus and nitrogen that are essential for life. In excess they may stimulate the growth of plants, algae and cyanobacteria (blue-green algae).
<b>On-site wastewater system</b>	A system used to treat wastewater on-site, where no reticulated sewer is available.
<b>Pathogen</b>	A biological agent or organism such as a virus, bacterium, protozoan or other microorganism that causes disease or illness.
<b>Permeability</b>	The characteristic of a soil texture, structure and particle size and that governs the rate at which water moves through it. Sandy soils have a high permeability; clay soils generally have a low permeability.
<b>Regulatory authority</b>	The government authority responsible for managing or controlling an aspect of on-site domestic wastewater systems – usually the local council, WaterNSW or the Environment Protection Authority.
<b>Riser</b>	A septic tank riser generally refers to a specific type of extension that is added to a septic tank. This structure can make accessing the tank easier, and help in the removal of any tank lids. It may also make locating a septic tank easier. Many building regulation codes now require a riser as part of the septic unit where the tank lids are lower than the ground surface.
<b>Severe frosts</b>	Areas of severe frost are defined as those where the overnight minimum air temperatures (Stephenson screen) are regularly below -3°C, corresponding to a ground temperature of approximately -5°C. Note that frost hollows and areas of cold air drainage may result in localised areas where frost is more severe than indicated by temperature records for the region.
<b>Onsite Wastewater Management Guidelines</b>	'Onsite Wastewater Management Guidelines' of the NSW Office of Local Government (April 2025).
<b>Soil depth</b>	The vertical depth of soil from the soil surface to the top of the C horizon (weathered rock), the parent rock or to the water table (periodic or permanent). This <u>does not</u> include the C horizon consisting of weathered rock.
<b>Special Areas</b>	Land mostly around WaterNSW's drinking water storages that was originally set aside to protect drinking water quality.
<b>State Environmental Planning Policy</b>	A State Environmental Planning Policy (SEPP) is a policy proposed by the Minister and approved by the Governor under the <i>Environmental Planning and Assessment Act 1979</i> that deals with environmental planning matters involving several local authorities.

TERM	DEFINITION												
<b>Stormwater</b>	Rainwater running off a surface.												
<b>Subsurface irrigation</b>	The distribution of water to the soil below the surface. An irrigation device with a delivery line and water emitters installed below the soil surface that slowly and frequently emit small amounts of water into the soil to irrigate plant roots												
<b>Subsoil irrigation</b>	Subsoil irrigation with regards to effluent management largely places effluent below the depth of the root zone of most grasses. at least 300 millimetres underground i.e. subsoil (as opposed to subsurface).												
<b>Subsoil drainage</b>	means drainage of the layer of soil under the topsoil on the surface of the ground. The subsoil may include substances such as clay and has only been partially broken down by air, sunlight, water.												
<b>Surface irrigation</b>	The distribution of water over the surface of soil. Sprinkler irrigation is application of water under pressure as simulated rain.												
<b>Suspended solids</b>	Suspended solids are usually clay or silt particles suspended in the water as a result of the motion of water or as colloids, causing turbidity.												
<b>Wastewater (domestic)</b>	All wastewater from the bathroom, laundry and kitchen, including toilet waste.												
<b>Wastewater Effluent Model</b>	(WEM) A GIS-based, effluent plume generation modelling tool that supports evaluation of on-site wastewater systems.												
<b>Waterbody (artificial)</b>	An artificial body of water, including any constructed waterway, canal, inlet, bay, channel, dam, pond, lake or artificial wetland, but does not include a dry detention basin or other stormwater management construction that is only intended to hold water intermittently.												
<b>Waterbody (natural)</b>	A natural body of water, whether perennial or intermittent, fresh, brackish or saline, the course of which may have been artificially modified or diverted onto a new course, and includes a river, creek, stream, lake, lagoon, natural wetland, estuary, bay, inlet or tidal waters (including the sea).												
<b>Watercourse</b>	Any river, creek, stream or chain of ponds, whether artificially modified or not, in which water usually flows, either continuously or intermittently, in a defined bed or channel, but does not include a waterbody (artificial).												
<b>Weighted Psorp value</b>	<p>The weighted value is similar to an arithmetic mean, but each data point contributes equally to the final value.</p> <p>Example of weighted average of phosphorus sorption of soil profile</p> <table border="1"> <thead> <tr> <th>Soil Depth (cm)</th> <th>Psorption (mg/kg)</th> <th>Psorption / soil layer</th> </tr> </thead> <tbody> <tr> <td>0-10</td> <td>150</td> <td>10 x 150 = 1,500</td> </tr> <tr> <td>10-30</td> <td>200</td> <td>20 x 200 = 4,000</td> </tr> <tr> <td>30-100</td> <td>400</td> <td>70 x 400 = 28,000</td> </tr> </tbody> </table> <p>Weighted Psorp = <math>\frac{(1,500 + 4,000 + 28,000)}{10 + 20 + 70} = 335 \text{ mg/kg}</math></p>	Soil Depth (cm)	Psorption (mg/kg)	Psorption / soil layer	0-10	150	10 x 150 = 1,500	10-30	200	20 x 200 = 4,000	30-100	400	70 x 400 = 28,000
Soil Depth (cm)	Psorption (mg/kg)	Psorption / soil layer											
0-10	150	10 x 150 = 1,500											
10-30	200	20 x 200 = 4,000											
30-100	400	70 x 400 = 28,000											

## 17 References and Further Reading

- Amador, J.A., & Loomis, G.W. (2018). *Soil-based Wastewater Treatment*. Soil Science Society of America. (this text provides detailed coverage of soil treatment processes).
- Biolytix. (2009). *Biolytix Wastewater Treatment Systems*.  
<http://www.biolytix.com/index.php>.
- Bounds, T.R. (1997). Design and Performance of Septic Tanks. In M.S. Bedinger, A. Johnson & J.S. Fleming (Eds.), *Site Characterization and Design of Onsite Septic Systems ASTM STP 901*. American Society for Testing Materials, Philadelphia. (describes the benefits of larger septic tanks for better treatment and improved sludge stabilisation leading to longer pump-out intervals).
- Commonwealth of Australia and States and Territories of Australia. (2022). *The National Construction Code Series 2022*. Australian Building Codes Board, Canberra.
- Converse, J.C., & Tyler, E.J. (1987). *Inspecting and Trouble Shooting Wisconsin Mounds*. Small Scale Waste Management Project, University of Wisconsin-Madison.  
<http://www.soils.wisc.edu/sswmp/pubs/15.16.pdf>
- Converse, J.C., & Tyler, E.J. (2000). *Wisconsin Mound Soil Absorption System: Siting Design and Construction Manual*. University of Wisconsin, Madison.  
<http://www.soils.wisc.edu/sswmp/pubs/15.24.pdf>
- Crites, R., & Tchobanoglous, G. (1988). *Small and Decentralised Wastewater Management Systems*. McGraw-Hill. (a good first principles text on on-site wastewater).
- Cromer, W.C., Gardner, E.A. & Beavers, P.B. (2001). An Improved Viral Die-off Method for Estimating Setback Distances. In *Proceedings of On-site '01 Conference: Advancing On-site Wastewater Systems* by R.A. Patterson & M.J. Jones (Eds). Published by Lanfax Laboratories, Armidale. ISBN 0-9579438-0-6, pp 105-112.
- Davey Pty Ltd.  
<https://www.daveywater.com/au>
- Ecomax Waste Water Technology. (2001). Presentation to the Hawkesbury-Nepean Catchment Management Trust. Sydney.
- Landcom. (2004). *Managing urban stormwater: soils and construction*. Vol. 1, 4<sup>th</sup> Edition, (the 'Blue Book' Vol.1). Parramatta, NSW.
- Lismore City Council. (2005). *The Use of Reed Beds for the Treatment of Sewage & Wastewater from Domestic Households*. Lismore, NSW.  
[https://lismore.nsw.gov.au/files/Use\\_of\\_Reed\\_Beds\\_for\\_the\\_Treatment\\_of\\_Sewage\\_and\\_Wastewater\\_from\\_Domestic\\_Households.pdf](https://lismore.nsw.gov.au/files/Use_of_Reed_Beds_for_the_Treatment_of_Sewage_and_Wastewater_from_Domestic_Households.pdf)
- Netafim  
<http://www.netafim.com.au/>
- NSW Department of Planning, Industry and Environment [DPIE]. (2021). *Considering Flooding in land use planning – Guideline*. Parramatta, NSW.
- NSW Ministry of Health. (2016). *Sewage Management Facility Vessel Accreditation Guideline* (Septic Tanks, Collection Wells, Sewage Ejection Pump Stations, etc.). February 2016. North Sydney, NSW.
- NSW Health. (2017). *Advisory Note No 3 Destruction, Removal or Reuse of Septic Tanks, Collection Wells, Aerated Wastewater Treatment Systems (AWTS) and Other Sewage Management Facility (SMF)*. Sydney, NSW.

<https://www.health.nsw.gov.au/environment/domesticwastewater/Documents/adnote3.pdf>

NSW Health. (2017). *Advisory Note No 4 Recommended Final Uses of Effluent based on the Type of Treatment*. Sydney, NSW.

<https://www.health.nsw.gov.au/environment/domesticwastewater/Documents/adnote4.pdf>

Office of Local Government [OLG]. (2025). *Onsite Wastewater Management Guidelines*. NSW Government.

Orenco Systems – (has information on septic tanks, dosing and sand filters).

<https://www.orencosystems.com>

Patterson, Dr R.A. (2006). *Evapotranspiration Bed Designs for Inland Areas*. Septic Safe Technical Sheet 05/15. NSW Department of Local Government.

<http://www.lanfaxlabs.com.au/papers/P51-Technical%20Sheet%20%20Evapotranspiration-aug06.pdf>

Rissy Plastics LLC

<http://www.rissyplastics.com/>

Siegrist, R.L. (2017). *Decentralised Water Reclamation Engineering. A Curriculum Workbook. Charm: Springer International Publishing AG*. (provides modern and wide-ranging coverage of onsite and decentralised wastewater topics with many worked examples).

[Standards Australia. \(2002\). AS/NZS 2566.2:2002 \(R2016\) Buried flexible pipelines Installation. SAI Global, Sydney.](#)

[Standards Australia. \(2002\). AS/NZS 2566.2:2002 AMD 2:2018 Buried flexible pipelines Installation. SAI Global, Sydney.](#)

[Standards Australia \(2008\). AS/NZS1546.1:2008 On-site domestic wastewater treatment units – Septic tanks. SAI Global, Sydney.](#)

[Standards Australia. \(2012\). AS/NZS 1547:2012 On-site domestic wastewater management. SAI Global, Sydney.](#)

[Standards Australia. \(2012\). AS/NZS 3000:2018 Electrical installations \(known as the Australian/New Zealand Wiring Rules\). SAI Global, Sydney.](#)

[Standards Australia. \(2021\). AS/NZS 3500 Set \(Parts 0-4\):2021 Plumbing and drainage. SAI Global, Sydney.](#)

[Standards Australia. \(2021\). AS/NZS 3500.1:2021 Plumbing and drainage Water services. SAI Global, Sydney.](#)

[Standards Australia. \(2021\). AS/NZS 3500.2 2021 Plumbing and drainage Sanitary plumbing and drainage. SAI Global, Sydney.](#)

Surge-flow

<http://www.surgeflow.com.au/>

Tyler, E.J. (2001, March 11-14). 'Hydraulic Wastewater Loading Rates to Soil', On-site wastewater treatment. In *Proceedings of Ninth National Symposium on Individual and Small Community Sewage Systems*. Fort Worth, Texas. American Society of Agricultural Engineers.

van de Graaff, R and Patterson, R.A. (2001). Explaining the Mysteries of Salinity, Sodicity, SAR and ESP in On-site Practice. In *Proceedings of On-site '01 Conference: Advancing On-site Wastewater Systems* by R.A. Patterson & M.J. Jones (Eds). Published by Lanfax Laboratories, Armidale ISBN 0-9579438-0-6, p 361 – 368.

Warrnambool City Council (warrnambool.vic.gov.au) – How to look after your wastewater treatment system brochure. *Your new Wastewater Treatment System*. Warrnambool City Council, Vic.

<https://www.warrnambool.vic.gov.au/sites/warrnambool.vic.gov.au/files/documents/property/waste/wastewater/Your%20New%20Wastewater%20System%20Brochure.pdf>

Wastewater Australia, Ultra GTS domestic

<http://www.wastewateraustralia.com.au/greywater/domestic-wastewater>

WaterNSW. (2025b). *Developments in Sydney's Drinking Water Catchment – Water Quality Information Requirements*. Parramatta, NSW.

WaterNSW. (2025a). *Neutral or Beneficial Effect on Water Quality Assessment Guideline [NorBE]*. Parramatta, NSW.

WaterNSW. (2025d). *Neutral or Beneficial Effect on Water Quality Assessment Tool: Consultant and Consultant Administrators User Guide*. Parramatta, NSW.

WaterNSW. (2025c). *Using a consultant to prepare your Water Cycle Management Study*. Parramatta, NSW.

## Appendix 1 – System Design Statement

## SYSTEM DESIGN

### On-site Wastewater and/or Effluent Management System

(to be prepared by the designer for supply to the installer)

---

**DATE:** DD/MM/YYYY

**ISSUED BY:** Wastewater System Designers Pty Ltd

**IN RESPECT OF:** Mr & Mrs Consumer

On-site wastewater service for Lot XX DP YYYYY,  
1 Rural Road, Septicville (Catchment Council)

#### DESCRIPTION OF PROJECT:

- Installation of an on-site wastewater system for a .....  
[insert relevant proposal e.g. a four bedroom dwelling].
- Treatment system: NSW Health accredited .....  
[insert relevant system name and model number].
- Nature of disposal system / Effluent management: .....  
.....  
[insert relevant effluent management e.g. 400m<sup>2</sup> subsurface drip irrigation].

#### DECLARATION:

This System Design dated DD/MM/YYYY has been prepared by:

Name: .....

Signature: .....

Title: .....

Date: .....

## 1. SITE LOCATION

The site is located at

Lot/DP: XXX/YYY  
Description: 4,000m<sup>2</sup> rural residential lot  
Address: 1 Rural Road, Septicville  
Council: Catchment Council

## 2. PROPOSED WASTEWATER SERVICING SYSTEM

### 2.1 System description

The proposed wastewater system to service the property consists of the following components:

- Treatment system (insert treatment level, relevant system and model number): .....  
.....  
.....  
[e.g. secondary treatment with disinfection by a NSW Health accredited]  
.....
- Nature of disposal system / Effluent management: .....  
.....  
[e.g. pumped dose loading via an automatic, hydraulically operated sequencing valve to two 200m<sup>2</sup> fields of pressure compensating subsurface drip irrigation, each fitted with an automated field flush valve].

### 2.2 System layout

The proposed location and set back distances of the effluent management area relevant to this site are to be consistent with the requirements in the Conditions of consent, WaterNSW's 'Developments in the Sydney Drinking Water Catchment – Water Quality Information Requirements', and:

- 3m if the effluent management area is downslope (or where flat) and 6m if the effluent management area is upslope, from property boundaries
- 15m and not upslope of in-ground pools and potable water tanks
- 40m from any drainage depressions, farm dams and roadside drainage and lot scale stormwater quality improvement devices (SQIDs)
- 100m from the high-water level of any watercourses, lakes and the full supply level for all water supply reservoirs.

For the location of the effluent management area see the Site Plan with the location marked (e.g. Figure 1) and for details of the subsurface irrigation system refer to the attached Standard Drawings [attach Standard Drawings 13A and 13B].

Key issues are:

- The exact location of the AWTS / septic tank is to be decided by the installer in consultation with the property owner. It is to be at least 3m from any building.
- A power supply (and telephone line if telemetry or an automated monitoring/alarm is fitted), will be required to deliver power to the treatment unit.

### 2.3 Installation of AWTS / Septic Tank (examples of requirements)

- The recommended grade of influent drain line is no less than 1:80.
- Installation is to be done in accordance with the AWTS manufacturer's Installation Manual.
- For this site additional ground anchoring is recommended.
- The wastewater treatment unit is to be buried to near ground level but 100 mm above ground level to avoid accumulation and ingress of stormwater under the tank lid.

### 2.4 Subsurface irrigation (examples of requirements)

The proposed effluent management area and suggested layout of the subsurface irrigation system is illustrated in the Site Plan and Standard Drawings. Guidance on the installation of the subsurface irrigation system can be found in the attached Standard Drawing [attach Standard Drawing 13A].

The specifications are:

- The length of supply line and return flush line will depend on location of the AWTS / septic tank relative to the effluent management area. These lengths are to be checked by the installer. The recommended supply line (distribution pipe) and return flush pipe is 25mm uPVC or polyethylene (low or medium density).
- Note that the irrigation field has been divided into two zones, serviced by an automatic, hydraulically operating sequencing valve.
- The effluent distribution lines are to be buried at a minimum depth of 300mm.
- Dripper laterals:
  - a minimum of 670m of pressure compensating 16 mm dripper line is required
  - drippers at 600mm spacing
  - dripper laterals are typically to be spaced at 600mm
  - dripper laterals are to be buried to a depth of 100-150mm.
  - the effluent irrigation area is to be fenced off / protected from grazing animals or vehicular access.
- Air release valves to be installed at the north-east and north-west corners of each field of the irrigation field (which are the high points).
- The effluent irrigation area, valve boxes and any other surface fittings must be located and protected to prevent damage by animals, vehicles and/or lawn mower.
- All components must be protected from damage by vehicles and other activities during any construction activities.

### 2.5 Stormwater

Run-on and stormwater is to be diverted around each subsurface irrigation field by means of a berm or diversion drain. Guidance on the installation of an appropriate earth bank and diversion drain can be found in the attached Standard Drawing [attach Standard Drawing 1 – Upslope Diversion Drain].

### 3. APPROVAL

Approval to install this system has been granted by ..... (insert Council name) Council. The Conditions of consent must be adhered to by the installer.

### 4. OPERATION AND MANAGEMENT

A servicing contract with an approved servicing agent is required for the life of the system by ..... (insert Council name) Council. Copies of the written service reports should be lodged with ..... (insert Council name) Council following each quarterly service.

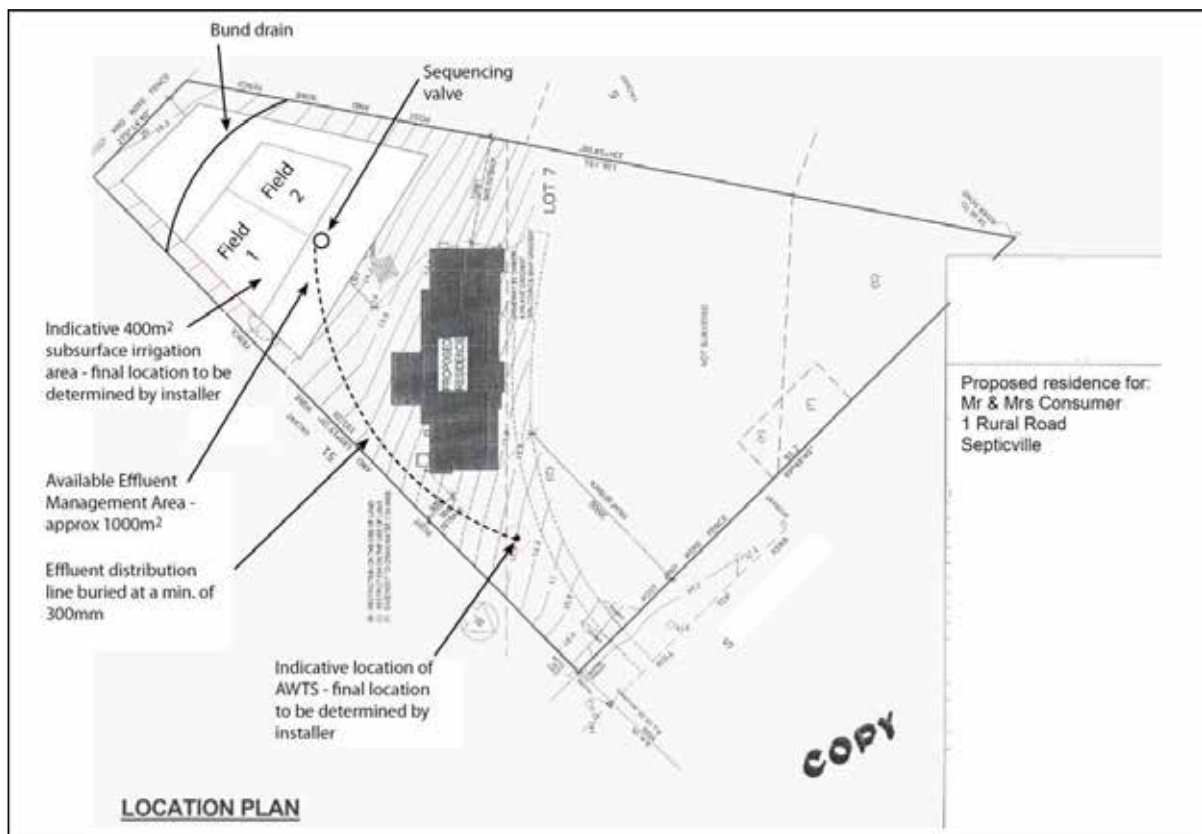

Figure 1. Example of the layout of an AWTS and irrigation field

## Appendix 2 – Design Producer Statement

# DESIGN PRODUCER STATEMENT

## On-site Wastewater and/or Effluent Management System Design

---

**ISSUED BY:** Wastewater System Designers Pty Ltd  
**TO:** Catchment Council  
**DA No.:** DAXXX/YYYY  
**TO BE SUPPLIED TO:** Mr & Mrs Consumer  
**IN RESPECT OF:** On-site wastewater system for 1 Rural Road, Septicville  
**AT:** Lot/DP: XX/YYYYYYY  
Description: 4,000m<sup>2</sup> rural residential lot  
Address: 1 Rural Road, Septicville

**Wastewater System Designers Pty Ltd** has been engaged by **Mr & Mrs Consumer** (property owners) to provide the technical design details for an on-site wastewater system.

The design has been carried out in accordance with:

- Developments in the Sydney Drinking Water Catchment – Water Quality Information Requirements (WaterNSW, 2023).
- Environment and Health Protection Guidelines: On-site Sewage Management for Single Households (DLG, 1998).
- [AS/NZS 1547:2012 'On-site domestic wastewater management](#)

For details of site assessment and design, refer to **Wastewater Management Report, 1 Rural Road, Septicville dated DD/MM/YYYY**.

Other resources used for this design include:

- e.g. 'Designing and Installing On-site Wastewater Management Systems' (WaterNSW, 2023)
- .....

This is an independent design, covered by a current policy of Professional Indemnity Insurance.

### DECLARATION:

I believe on reasonable grounds that this design has been carried out in accordance with agency and council requirements, and best practice in on-site wastewater design principles and procedures.

**NOTE: This statement does not approve the installed system.**

Under certain conditions, **Wastewater System Designers Pty Ltd** is available to certify the installed system. These conditions include:

- the technology supplier(s) take(s) full responsibility for the stated quality and performance of technologies and other equipment supplied
- the installer(s) take full responsibility for installing the system as specified by any conditions of consent and **Wastewater System Designers Pty Ltd** design reports unless departure from the stated specification(s) is subsequently agreed between the installer and **Wastewater System Designers Pty Ltd** and approved by the consent authority
- **Wastewater System Designers Pty Ltd** is to be informed before installation, and engaged, under separate contract, if required to supervise installation of all specified system components.

**DISCLAIMER:**

*Approval is to be sought from **Wastewater System Designers Pty Ltd** should variations to the specification and layout in this report/drawing be considered necessary by the installer before or at the time of installation. Failure to do so will invalidate the Design Producer Statement and **Wastewater System Designers Pty Ltd** will no longer take responsibility for the design.*

*The client is to make full disclosure of relevant information on existing and/or proposed activities on the site that will influence estimation of likely daily wastewater quantity (based on the number of potential bedrooms and other wastewater producing activities) and quality (in particular any chemicals in the water supply and/or wastewater stream potentially toxic to biological wastewater processes). This design is based on the site assessment carried out by **Wastewater System Designers Pty Ltd**.*

*Subsequent changes to the site that might affect the topography and soil profiles are to be notified by the client. Failure, by the client, to provide this information will invalidate this Design Producer Statement.*

Name: .....

Signature: .....

Title: .....

Date: .....

For: **Wastewater System Designers Pty Ltd**

Other conditions that may be specified by **Wastewater System Designers Pty Ltd** under the contract to supervise installation include:

- .....
- .....
- .....

## Appendix 3 – Installation certificate

# COMPLETION OF WORKS INSTALLATION CERTIFICATE

## On-site Wastewater and/or Effluent Management System

(to be prepared and issued by the licensed installer)

---

**ISSUED BY:** *On-Site System Installers Pty Ltd*

**TO BE SUPPLIED TO:** *Catchment Council (DA No. XXX/YYYYY)*

**IN RESPECT OF:** *Mr & Mrs Consumer*  
*On-site wastewater service for 1 Rural Road, Septicville*  
*(Catchment Council)*

**SITE DETAILS:** *Lot/DP: XXX/YYY*  
Description: .....  
[insert relevant description]

### DESCRIPTION OF PROJECT:

- *Installation of an on-site wastewater system for a .....  
[insert relevant proposal e.g. a four bedroom dwelling].*
- *Treatment system: NSW Health accredited .....  
[insert relevant system name and model number].*
- *Nature of disposal system / Effluent management:.....  
.....  
[insert relevant effluent management e.g. 400m<sup>2</sup> subsurface drip irrigation].*

**DATE OF SITE INSTALLATION INSPECTION:** *DD/MM/YYYY*

**INSTALLED IN ACCORDANCE WITH:** *Conditions of consent and Wastewater System Designers Pty Ltd System Design, 1 Rural Road, Septicville, dated DD/MM/YYYY.*

**REPORT:** *Variations: None. Installed as indicated on Site Plan in System Design.*

### DECLARATION:

*I believe on reasonable grounds that all of the wastewater works have been completed in accordance with Council Consent Number 123456 and Wastewater System Designers Pty Ltd System Design dated DD/MM/YYYY.*

Name: ..... Signature: .....

Title: .....

**For:** *On-Site System Installers Pty Ltd*

**Date:** *DD/MM/YYYY*

**cc:** *Mr & Mrs Consumer*

## Appendix 4 – Standard Drawing 1 – Upslope Diversion Drain

Referenced in sections 8, 9, 10, 11, 12 & 13

### Cross Section: Upslope Diversion Drain

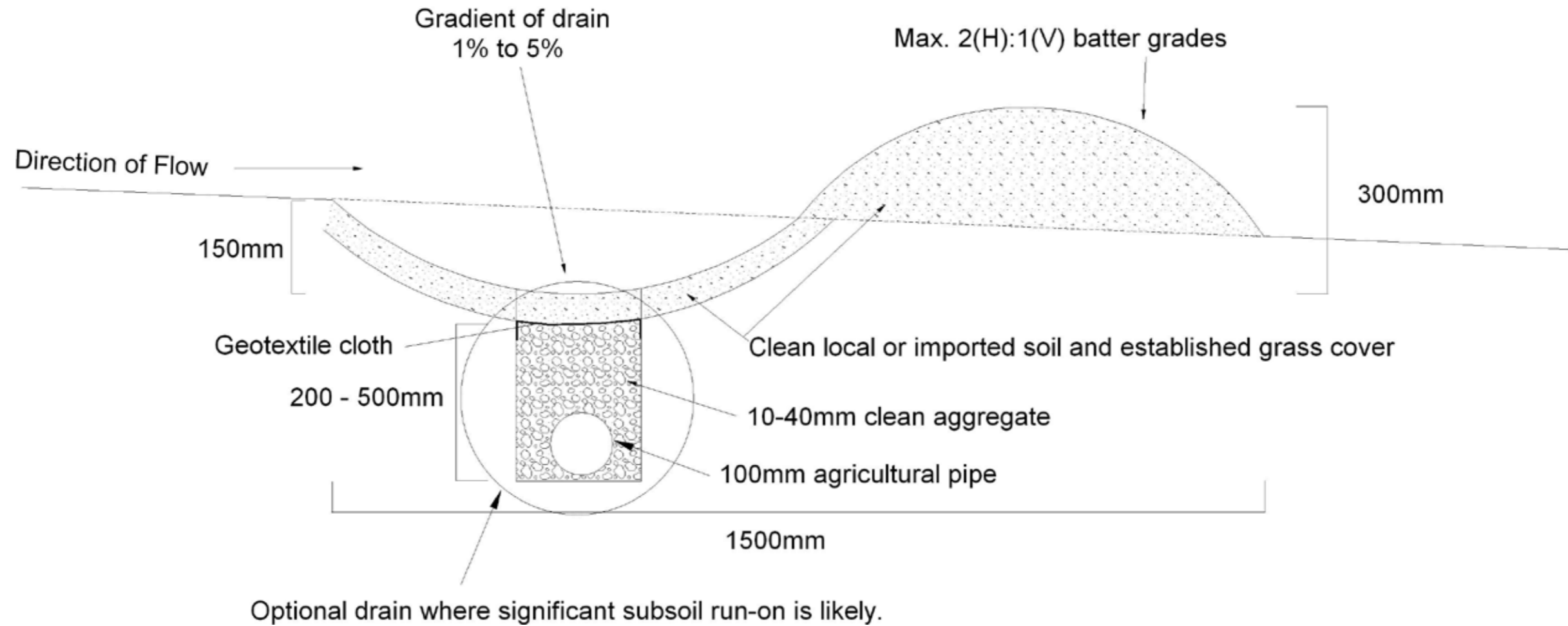

**Standard Drawing 1 – Upslope Diversion Drain**  
(not to scale)



**WaterNSW Head Office**

169 Macquarie Street  
Parramatta NSW 2150

Phone: 1300 662 077

Email: [Environmental.Assessments@waternsw.com.au](mailto:Environmental.Assessments@waternsw.com.au)

Web: [www.waternsw.com.au](http://www.waternsw.com.au)

**Mailing Address**

PO Box 398  
Parramatta NSW 2124

Office hours

9.00am to 5.00pm

Monday to Friday